



Operation **Manual**

MH800 Series Electro-hydraulic Servo System



Preface

INVT MH800 series electro-hydraulic servo is designed especially for hydraulic devices eg injection molding machine, casting machine, oil press, etc. It adopts high performance vector control and is featured with energy saving, high precision, high efficiency and strong durability. MH800 series servo carries abundant external extension interfaces and CAN communication interfaces for forming multi-pump parallel system and realizing hydraulic control of large-flow system.

Thanks for choosing the MH800 series electro-hydraulic servo system manufactured by Shanghai INVT Industry Technology Co., Ltd. Read this manual carefully to ensure proper operation. Please keep this operation manual in a safe place for future reference.

- ◆ This manual is suitable for the following users:
 - 1) Designer of control system
 - 2) Installation or wiring personnel
 - 3) Operation or maintenance personnel
- ◆ Below requirements must be followed when you have not read through this operation manual :
 - 1) Installation environment must be free from moisture, corrosive gases and combustible gases;
 - 2) Do not connect the grid power to the U, V and W terminals of the motor directly during wiring, otherwise, the drive and motor may be damaged;
 - 3) The grounding wire must be grounded in a reliable way;
 - 4) When power is applied, do not disassemble the drive, motor, oil pump or change the wiring;
 - 5) Do not touch the cooling fins during working to avoid scald.

Our company provides all-around after-sale and maintenance service. Do not disassemble the drive, LED panel or motor enclosure by yourself. Any change or damage made to the drive will void the warranty and our company will not assume the liability for the consequences thereof.

If there is any question, please contact the distributor or customer service center of our company.

Content

Chapter 1	Safety Precautions	1
1.1	Safety definition.....	1
1.2	Safety guidelines.....	1
Chapter 2	Product information	3
2.1	Product confirmation.....	3
2.2	Nameplate of the servo drive.....	3
2.3	Model instruction of the servo drive.....	3
2.4	Specification of servo drive.....	4
2.5	Technical condition of servo drive.....	5
2.6	External dimension of servo drive.....	7
2.7	Nameplate of servo motor.....	8
2.8	Model instruction of servo motor.....	8
2.9	Specification of servo motor.....	9
2.10	Installation dimension of servo motor.....	10
Chapter 3	Mechanical installation	12
3.1	Installation environment.....	12
3.2	Installation of the drive.....	12
3.3	Disassemble junction box of the drive.....	13
3.4	Installation of servo motor.....	14
Chapter 4	Electrical wiring	16
4.1	Wiring precautions.....	16
4.2	Selection of switch, contactor and cable diameter.....	17
4.3	Terminal layout.....	18
4.4	Standard wiring.....	19
4.5	Instruction of jumper function.....	21
4.6	Main circuit wiring.....	22
4.6.1	Name and function of main circuit terminal (CN6).....	22
4.6.2	Name and function of resolver signal connector (CN2).....	23
4.6.3	Motor power cable and temperature resistor terminal (k series motor).....	24
4.6.4	Motor resolver terminal (k series motor of our company).....	24
4.6.5	Motor terminal (PHASE motor).....	25
4.6.6	Typical main circuit wiring instance.....	25
4.6.7	Wiring process of main circuit terminals (CN6).....	26
4.7	IO signal wiring.....	27
4.7.1	Name and function of IO signal connector (CN5).....	27
4.7.2	I/O output signal connector terminal (CN1A).....	29
4.7.3	Typical wiring diagram of control signal.....	29
4.8	CAN/485 connector terminal (CN3).....	30
4.9	Name and function of serial communication signal connector (CN1B).....	30
4.10	Interface circuit.....	31

4.10.1	Analog input circuit interfaces	31
4.11	Digital input circuit interface	31
4.11.1	Digital output circuit interfaces	32
Chapter 5	Display and function	33
5.1	External HMI display and operation	33
5.1.1	HMI panel interface instruction.....	33
5.2	Function of control panel keys	34
5.2.1	Key function of operation key area	34
5.2.2	Key function in direction key area	34
5.2.3	Key function of setup key area.....	34
5.3	External HMI function	34
5.3.1	List of monitor menus	36
5.3.2	List of setup menus	37
5.3.3	Commissioning menu list.....	53
5.3.4	Multi-pump menu list	57
5.3.5	Parameter programming menu list.....	60
5.3.6	Shortcut menu list.....	61
5.4	LED display and operation.....	64
5.4.1	LED panel instruction	64
5.4.2	LED state bit instruction.....	66
5.5	LED panel function	66
5.5.1	Keypad operation mode.....	66
5.5.2	Shot-cut mode.....	67
5.5.3	Quick setting mode.....	68
5.5.4	Monitor mode	71
5.5.5	Setting mode	73
5.5.6	Commissioning mode	90
5.5.7	Multi-pump mode.....	92
Chapter 6	Motor parameter autotuning.....	95
Chapter 7	Oil pump control	97
7.1	Oil pump control mode overview.....	97
7.2	Common pressure priority control (P control)	97
7.3	Flow priority control (Q control)	98
7.4	Dual-displacement pump control.....	99
Chapter 8	Multi-pump parallel control.....	101
8.1	Multi-pump mode.....	101
Chapter 9	Running commissioning.....	109
9.1	Commissioning flowchart.....	109
9.2	Commissioning procedures	109
9.2.1	Commissioning preparations	109
9.2.2	Motor model selection	109
9.2.3	Pump model selection	110

9.2.4	Pressure feedback zero position calibration mode	112
9.2.5	Motor parameter autotuning and motor initial angle measurement	113
9.2.6	Low speed jogging and venting.....	116
9.2.7	Pressure calibration.....	121
9.2.8	Flow calibration	127
9.2.9	Hold pressure test	128
9.2.10	Calibration of overflow valve.....	129
9.2.11	Calibration review.....	130
9.2.12	Automatic operation and system performance adjustment	130
Chapter 10	Alarm and solution.....	131
10.1	Protection display list.....	131
10.2	Analysis on fault source.....	134
10.3	Protection causes and solutions	134
10.4	Fault rule-out flowchart.....	139
Chapter 11	Maintenance and inspection.....	155
11.1	Precautions	155
11.2	Inspection items	155
11.3	Tramegger test.....	156
11.4	Replacement of the parts.....	156
Chapter 12	Accessories.....	157
12.1	Accessories model list	157
12.2	Noise filter	157
12.3	Brake resistor model selection and installation.....	159
12.4	Pressure sensor	163
12.5	External HMI options	163
Chapter 13	Contact us	164

Chapter 1 Safety Precautions

Read this manual carefully and follow all the safety precautions before moving, installing, operating and servicing the product. If you ignore the safety precautions, physical injury or death may occur, or damage may occur to the devices.

If any physical injury or death or damage to the devices occurred due to user's ignoring of the safety precautions in the manual, our company will not be responsible for any damages thereof and we are not legally bound in any manner.

1.1 Safety Definition

The precautions related to safety operations are classified into "Danger", "Warning" and "Note".



Danger: This mark indicates the potential danger which may cause serious physical injury or death if operation requirements are not followed.



Warning: This mark indicates the potential danger which may cause physical injury or device damage if operation requirements are not followed.

NOTE: This mark indicates the potential danger which may cause physical injury if operation requirements are not followed.

1.2 Safety Guidelines

	1. The installation and maintenance work can be carried out by trained and qualified professionals only.
	2. Do not check the wiring or replace any component when the power is applied. Before wiring and checking, confirm all the input power sources are disconnected, and wait for at least 10 minutes or confirm the DC bus voltage is less than 36V.
	3. Use insulation protection tools during inspection, otherwise electric shock or physical injury may occur.
	4. Connect the grounding wires in a reliable way and the wiring work can be carried out by professionals only, otherwise electric shock or fire may occur.
	5. Do not install the motor, brake resistor or the drive near the combustible objects, otherwise fire may occur.
	6. Do not refit the product unless authorized, otherwise electric shock, fault, burn or fire may occur.
	1. When carrying the motor, do not pull up the connection part of the aviation plug to avoid damage to the electrical connection parts and physical injuries caused by the falling of motor.
	2. When installing the motor, do not knock on the motor to avoid damage to the precision components or adverse impact on the precision.
	3. During full load operation, the surface temperature of this servo motor may

	<p>reach 100°C, which is within the allowed range but may cause danger of scald, therefore, motor should be installed in a place where it is hard for human beings or animals to access.</p>
	<p>4. As the external brake resistor may become hot when motor brakes frequently, the cooling air ducts must be in good condition. It is recommended to install the external brake resistor in a place outside the control cabinet (eg in the air outlet of the ventilator on the top) and take reliable preventative measures against waterdrops and human contact; if it must be installed inside the cabinet, it should be installed near the air outlet of the ventilator on the top and far away from other components.</p>
	<p>5. Ensure to check all the external connection cables before the initial power up to avoid major accidents caused by wrong wiring.</p>
	<p>6. The motor should carry no load during initial switch-on, and depending on the operation situation, switch off the enabling anytime if necessary.</p>
	<p>7. Start or stop the servo system by enabling instead of switching on/off.</p>
	<p>8. This product carries electrolytic capacitor, integrated circuit, epoxy plate, etc., all of which should be disposed as industrial waste when discarded, otherwise, physical injury or environmental pollution may occur.</p>
<p>NOTE</p>	<p>1. Ensure the drive is free from physical shock and vibration during moving and installation; do not hold the product by its front cover only to avoid fall off.</p>
	<p>2. Users must prevent the screws, cables and other conductive objects from falling into the drive.</p>
	<p>3. R, S and T are power input terminals, while U, V and W are output motor terminals. Connect input power cables and motor cables correctly; otherwise the drive may be damaged.</p>
	<p>4. Before using the drive, ensure its front cover or junction box is closed, otherwise electric shock may occur.</p>
	<p>5. Tighten the screws with proper torque during installation and wiring.</p>
	<p>6. Do not carry out insulation voltage withstand test on the drive; do not use megameter to test the control circuit of the drive.</p>

※ For application sites susceptible to occasional product faults, namely the occasional fault may cause major accident or loss, please take extra consideration on the device safety.

※ The manufacturer, retailer and service provider will not assume any correlated loss or joint liability caused by the servo system faults, excluding the servo system itself.

Chapter 2 Product Information

2.1 Product Confirmation

Confirm the following items upon receiving the products.

Items To Be Confirmed	Remark
Whether the products received are consistent with the product models you ordered?	Confirm by the "model" column on the nameplate of the servo motor and servo drive
Whether the rotating shaft of the servo motor can run smoothly?	The rotating shaft should be able to be rotated manually,
Whether there is any damage?	A cosmetic check on the product to ensure no damage is caused during shipment, etc.
Whether the attachments and materials are complete?	Check the attachments, certificate of qualification and the warranty certificate according to the packing list.

If any inconformity occurred, contact the retailer or the sales agency of our company immediately.

2.2 Nameplate of the Servo Drive

伺服驱动器 SERVO DRIVES		型号: MODEL: SV-MH800-4R4-33-S00
输入 INPUT	3P AC 380V (-15%~+10%)	47Hz~63Hz
输出 OUTPUT	3P AC 0V~Vin	0~400Hz 13A 4.4kW
S/N:		CE
 上海英威腾工业技术有限公司 INVT Industrial Technology (Shanghai) Co., Ltd.		

2.3 Model Instruction of the Servo Drive

SV	-MH800	-5R5	-33	-S	00
Servo product	Electro-hydraulic product series	Power range 4R4: 4.4KW 5R5: 5.5KW 7R5: 7.5KW 011: 11KW 015: 15KW 018: 18KW 025: 25KW 030: 30KW 037: 37KW 045: 45KW	Input voltage type 33: 3PH 380V 32: 3PH 220V 22: 1PH220V	Communication plate type S: Standard type N: EtherCat bus type	Extension code 00: No differentiation 01: Chende 02: Beston

SV	-MH800	-5R5	-33	-S	00
		055: 55KW 075: 75KW 095: 95KW			
Basic product model information (Software display)					

2.4 Specification of the Servo Drive

Drive model SV-MH800-	4R4-33-S00	5R5-33-S00	7R5-33-S00	011-33-S00	015-33-S00
Applicable motor capacity [kW]	4.4	5.5	7.5	11	15
Rated output current [Arms]	13	18	22	26	30
Rated input current [Arms]	18	24	28	32	37
Max output current [Arms]	25	35	46	53	64
Input power	AC380V(-15%) – 440V(+10%) 47Hz – 63Hz				
Weight	6.5Kg	7.0kg	9kg	9.5kg	9.5kg
Regenerative brake resistor	40Ω 500W				15Ω500W

Drive model SV-MH800-	018-33-S00	025-33-S00	030-33-S00	037-33-S00	045-33-S00
Applicable motor capacity [kW]	18	25	30	37	45
Rated output current [Arms]	38	50	64	80	99
Rated input current [Arms]	47	60	75	94	109
Max output current [Arms]	95	113	141	190	255
Input power	AC380V(-15%) – 440V(+10%) 47Hz – 63Hz				
Weight	11.5Kg	11.5kg	30kg	32kg	51kg
Regenerative brake resistor	15Ω 500W		10Ω 2000W		Connect two 10Ω 2000W resistors in parallel

Drive mode SV-MH800-	055-33-S00	075-33-S00
Applicable motor capacity [kW]	55	75
Rated output current [Arms]	123	156
Rated input current [Arms]	135	166
Max output current [Arms]	283	318
Input power	AC380V(-15%) – 440V(+10%) 47Hz – 63Hz	
Weight	52 Kg	67Kg
Regenerative brake resistor	Connect two 10Ω 2000W resistors in parallel	Connect two 30Ω 2000W resistors in parallel, it is necessary to install brake unit DBU100H-060-4

2.5 Technical Condition of Servo Drive

Basic specification	Control mode		3PH full-wave rectification, IGBT PWM control sine wave current drive mode	
	Max output frequency		400 Hz	
	Motor position sensor		Resolver resolution: 4096/rev	
	Application condition	Application/storage temperature	-20 – +55 °C (derating is needed if the temperature is above 45°C)/ -20 – +85 °C	
		RH	Below 95%RH (no condensation)	
		Air	Indoors (no sunlight), no corrosive gases, combustible gases, oil gases or dust	
		Elevation	Below 2000m	
	Protection level		IP20	
	Cooling mode		Forced air cooling	
	Digital signal	Input	Six inputs: ① servo enable (S-ON); ② alarm clear (ALM–RST); ③ 4 external control input interfaces(I1, I2, I3, I4). Refer to 4.7 for detailed function	
		Output	Four opto-coupler outputs:① alarm output(ALM); ② drive ready(S-RDY); ③ Refer to 4.7 for the function of control output interface; One relay output; displacement switching control of dual-displacement pump (O1)	
	Analog signal	Input	Three inputs 10-bit A/D (AIN1, AIN2, AIN3)	
		Output	Two outputs 10-bit D/A (ANOUT1, ANOUT2), users can set internal parameter output via LED panel or external HMI	
	Power	Output	Provide 15V reference power to the external	
	Communication function	CAN communication	Communicate with upper PC; carry out parameter setup and drive control; command reference and parameter save, etc.	
RS485				
LED display panel and		6-bit LED display, four function keys		

	keypad	
	External HMI	External HMI realizes communication with the drive, parameter setup, drive control, command reference and parameter save via RS485 port.
Control function performance	Control mode	Select the mode via parameter setup: ①process control; ②speed control
	Control input	Hydraulic control command input: can be set to analog input, CAN communication or RS485 communication Speed command input: CAN communication or RS485 communication
	Multi-pump parallel control	Can control 16 pumps; three working modes (multi-pump, composite, multi-mode)
	Pressure control precision	± 1 bar(screw pump)
	Flow control precision	$\pm 0.5\%$ FS
	Pressure control step response	≤ 100 ms flow reference $>70\%$ (screw pump)
	Speed step response during speed control	≤ 50 ms feedback pressure is less than 10bar
	Flow correction function	Carry out pressure calibration based on the characteristics of various pumps
	Speed command input	RS485, CAN communication
	Speed control precision	$\pm 0.5\%$
	Torque response time	≤ 2 ms
	Overload capacity	MH800-4R4-33,MH800-5R5-33,MH800-7R5-33,MH800-018-33,MH800-030-33,MH800-037-33, MH800-045-33, MH800-025-33, MH800-075-33: lasts 5m for 141% of rated current; MH800-011-33,MH800-015-33, MH800-055-33: lasts 5m for 130% of rated current; for the max output current, lasts 30s for all models.
Protection function	Hardware error	Overcurrent, DC overvoltage, DC undervoltage, brake resistor damage, module over-temperature, pressure sensor fault, FWD/REV overspeed, brake overload, etc.
	Software error	Software fault, task re-entry, etc.
	Alarm record memory	Can store 5 alarm records

※ If the actual temperature of the application site exceeds 45°C, derate by 3% for every additional 1°C, in addition, the servo drive cannot be used in the environment above 55°C. For cabinet installation, the ambient temperature of the servo motor is the air temperature inside the cabinet.

2.6 External Dimension of Servo Drive

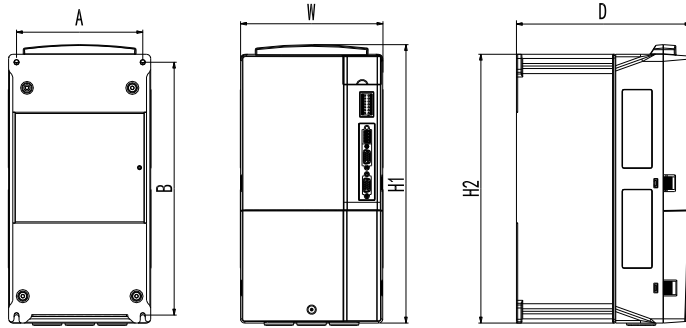

4.4-25kW

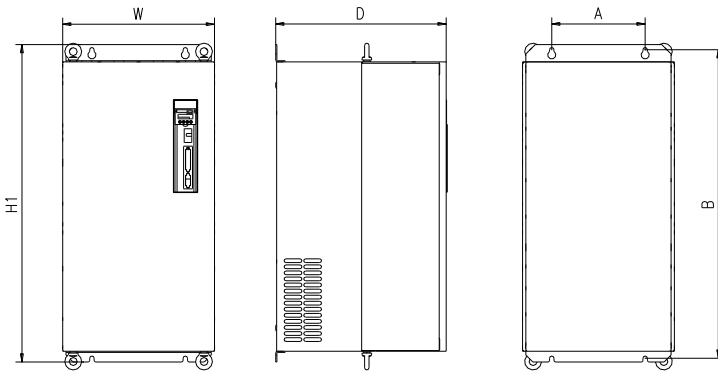

75kW

The external dimension of the servo drive is as below:

Model	External Dimension			Installation Dimension		Diameter of Installation Bore (mm)
	H1 (mm)	W (mm)	D (mm)	A (mm)	B (mm)	
SV-MH800-4R4-33-S-00	332	170	208	151	301	M5(φ6)
SV-MH800-5R5-33-S-00						
SV-MH800-7R5-33-S-00	342	230	208	210	311	M5(φ6)
SV-MH800-011-33-S-00						
SV-MH800-015-33-S-00						
SV-MH800-018-33-S-00	407	255	245	237	384	M6(φ7)
SV-MH800-025-33-S-00						

Model	External Dimension			Installation Dimension		Diameter of Installation Bore (mm)
	H1 (mm)	W (mm)	D (mm)	A (mm)	B (mm)	
SV-MH800-030-33-S-00	555	270	325	130	540	M6(ϕ 7)
SV-MH800-037-33-S-00						
SV-MH800-045-33-S-00	554	338	329	200	535	M8(ϕ 9.5)
SV-MH800-055-33-S-00						
SV-MH800-075-33-S-00	680	325	365	200	661	M8(ϕ 9.5)

2.7 Nameplate of the Servo Motor



2.8 Model Instruction of the Servo Motor

K 038 F 18 -C 18 P- 33 R 1 E-A

① ② ③ ④ ⑤ ⑥ ⑦ ⑧ ⑨ ⑩ ⑪ ⑫

① Servo motor series	
② Rated torque	038-38N.m
	111-111N.m
③ Cooling method	F-Air cooling
	N-Natural cooling
	W-Water cooling
	Y-Oil cooling
④ Rated rotary speed	18-1800 rated rotary speed/100
	15-1500 rated rotary speed/100
⑤ Production line code	
⑥ Flange diameter	11-114mm
	18-180mm
	25-250mm
⑦ Shaft extension type	P- Flat key

	G-Principal axis
	N-Internal spline
	W-External spline
⑧ Rated input voltage	33-3-phase 380V input voltage
	32-3-phase 220V input voltage
	12-single-phase 220V input voltage
⑨ Feedback device type	R-Resolver
	A-Incremental encoder
⑩ Pole pairs	1-1 antipode
	3-3 antipode
	A-10 antipode
⑪ Brake mode	E-Without braking
	B-With braking
⑫ Special configuration	

2.9 Specification of the Servo Motor

Model	K038F18	K058F18	K072F18	K091F15	K111F15	K132F18	K187F18	K235F2	K341F18C
	C18P-33R1	C18P-33R1	C18P-33R1	C18P-33R1	C18P-33R1	C18P-33R1	C25P-33R1	0C25P-33R	25P
	E-A	E-A	E-A	E-A	E-A	E-A	E-A	1E-A	-33R1E-A
Rated output power kW	7.5	11	13	15	18	25	35	50	61
Max output power kW	18	28	33	39	50	63	91	125	152
Counter-emf Vrms /1000rpm	180	182	180	200	237	198	167	147	142
Rated torque Nm	38	58	72	91	111	133	187	235	341
Max torque Nm	120	174	220	275	306	400	487	705	975
Rated current A (rms)	14	20	25	30	35.2	49	74.6	113	155.3
Max current A (rms)	56	76	88	102	97	147	194	339	443
Rated speed rpm	1800	1800	1800	1500	1500	1800	1800	1800	1800
Max speed rpm	2500	2500	2500	2200	2200	2500	2500	2500	2500

Torque parameter Nm/Arms	2.8	2.9	2.8	3.2	3.86	3.17	2.58	2.3	2.2
Voltage level V (rms)	380								
Rated time	Continuous								
Heat resistance level	F								
Insulation voltage withstand	AC1800V 1m <10mA								
Insulation resistor	DC1000V, above 50MΩ								
Vibration level	<15um								
Protection level	Fully-closed self-cooling IP54(except for shaft pass-through part)								
Anti-vibration performance	Withstand vibration test at level 1 and level 2 environment conditions stipulated in table 4.26 in GB/T 7345-94								
Storage temperature	-25 – +85 °C								
Ambient temperature	-20 – +45 °C								
Ambient RH	20% – 95% (no condensation)								
Excitation mode	Permanent magnet type								
Installation mode	IMB5								
Position detection	1 level of resolver								

2.10 Installation Dimension of the Servo Motor

1) Servo motor dimension of K038F18C18P – K132F18C18P

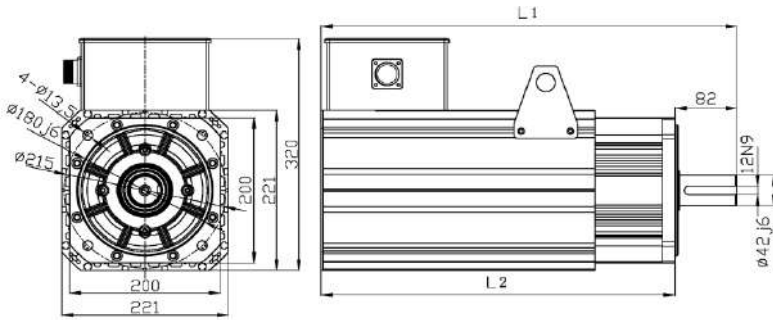

Motor Model	Length(mm)	
	L1	L2
K038F18C18P	412.5	330.5
K058F18C18P	447.5	365.5
K072F18C18P	482.5	400.5
K091F15C18P	517.5	435.5
K111F15C18P	552.5	470.5
K132F18C18P	622.5	540.5

2) Servo motor dimension of K187F18C25P, K235F20C25P, K341F20C25P

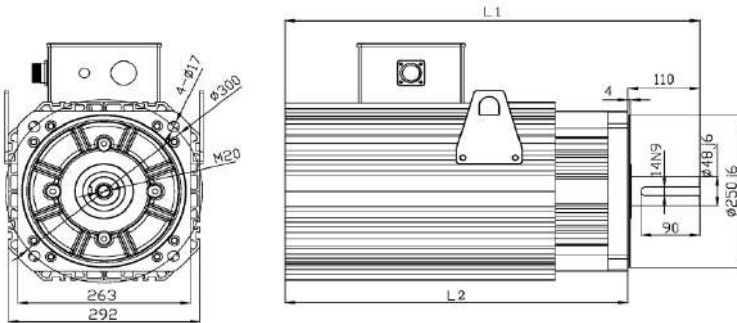

Motor Model	Length(mm)	
	L1	L2
K187F18C25P	647	537
K235F20C25P	727	617
K341F18C25P	845	735

Chapter 3 Mechanical Installation

3.1 Installation Environment

In order to ensure perfect performance and long-term service life, install MH800 servo drive in below recommended environment to ensure the drive is free from damages.

Note	1) Avoid direct sunlight and do not use in outdoor environment directly.
	2) Do not use in the environment where there is corrosive gas or liquid.
	3) Do not use in the environment where there is oil mist or water splash.
	4) Do not use in the environment where there is salt mist.
	5) Do not use in the environment where there is raindrops or humidity.
	6) Filtering devices must be installed if there are metal powders or floating fibers in the air.
	7) Do not use in the environment where there is mechanical shock or vibration.
	8) If the ambient temperature is above 55°C, proper measures must be taken to lower the temperature.
	9) Fault may occur to the device if the ambient temperature is too cold or too hot. It is recommended to use it within -20°C – +55°C.
	10) Away from power noise eg electric welding machine and large-power devices.
	11) Radioactive materials will impact the usage of the device.
	12) Away from combustible objects, diluents and solvents.

3.2 Installation of the Drive

- 1) The installation direction should be vertical to the wall direction, and the upper and lower part of the drive should reserve enough space (larger than 200mm) for ventilation and cable connection, thus facilitating heat dissipation and operation;
- 2) Adopt natural convection mode or the fan to cool down the servo drive;
- 3) Fix the servo unit firmly onto the installation surface through the four installation holes.
- 4) When multiple drives are installed inside the machine cabinet:
 - a) The front side of the servo drive (installation side of the LED panel) should face the operation staff;
 - b) The installation position of the ventilator inside the cabinet must be proper to ensure the drive can be cooled down through the fan and natural convection; if the installation position is improper, the ambient temperature of the drive may rise and the cooling effect will be impacted;
 - c) During parallel installation, reserve more than 50mm space on both sides horizontally and more than 200mm space on both sides vertically. In addition, install cooling fan on the upper part of the servo unit. Keep the temperature inside the control cabinet even to prevent overheat of part of the servo unit;

Installation diagram of the drive

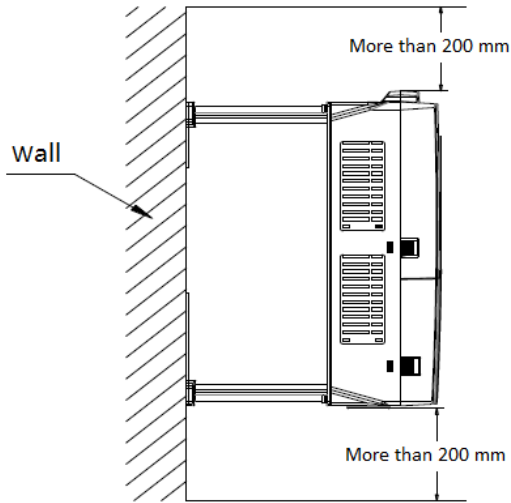

Installation diagram of the ventilator inside the cabinet

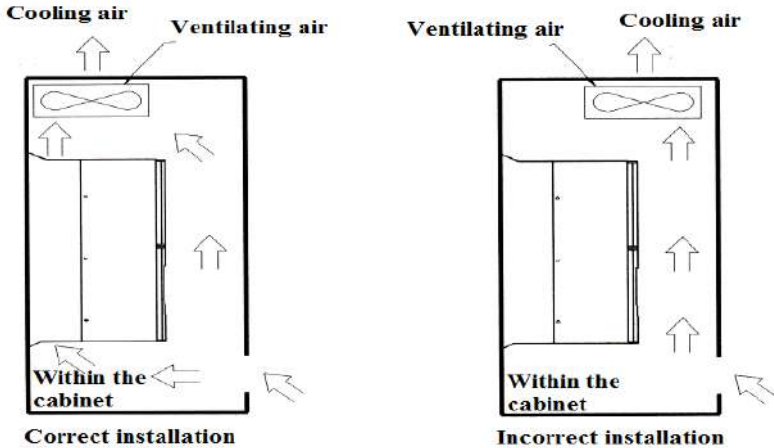

3.3 Disassemble Junction Box of the Drive

Disassemble the junction box of servo drive: (take SV-MH800-011-33-S00 as an example)

1. Unscrew the two screws used to fix the junction box and take off the screws;
2. Pull out the junction box.

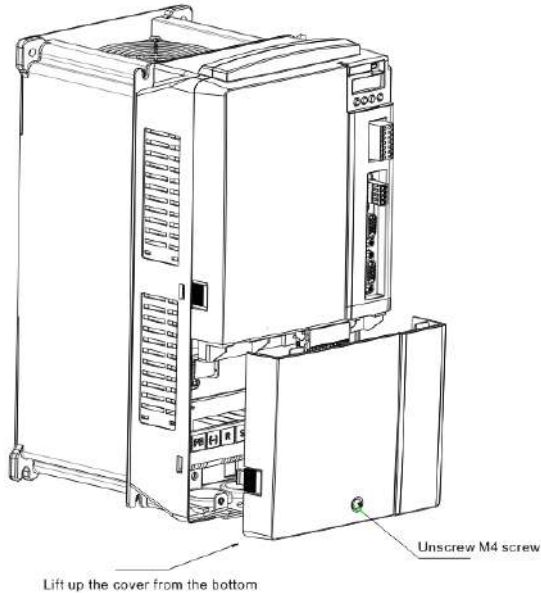

Install junction box of servo drive: (take SV-MH800-011-33-S00 as an example)

1. Place the junction box into the convex groove of the system and push it to match with the gap of the shell;
2. Tighten the two screws used to fix the junction box.

3.4 Installation of the Servo Motor

Install the motor according to below installation instruction to ensure a safe and stable operation of the servo motor.

Note	1. The servo motor can be installed horizontally or vertically.
	2. It is recommended to use coupling when connecting to machinery. The shaft center of the servo motor should be in the same linear with that of the machinery, otherwise vibration, damage to the bearing or encoder may occur.
	3. There is positioning requirement on the installation of feedback component (optical encoder, resolver), namely there is fixed relative position between the feedback component and motor rotor/stator, which cannot be disassembled or replaced by the users.
	4. Do not apply "tension" on the wire, especially the delicate core wires of the signal cable. Do not stretch the wires too tight during wiring (usage).
	5. During installing the motor, avoid direct shock on the bearing to prevent the precision parts (optical encoder, resolver) on the bearing from being damaged or deteriorated.

The installation procedures of the motor and pump are listed below:

- 1) Connect the flat key to the pump and cover up with half of the coupling, and insert the bolt without screwing it tight;
- 2) Connect the flat key to the motor and cover up with the other half of the coupling, then insert the bolt without screwing it tight;
- 3) Connect the pump to the motor bracket and screw tight the bolts after confirming the direction;
- 4) Connect the motor to the motor bracket and screw tight the bolts after confirming the direction;
- 5) Adjust the clearance of the flexible coupling to 2 – 3mm and screw tight the bolts on both ends; ensure there is no abnormal noise when rotating manually;
- 6) Put the motor, motor bracket and connection units of the pump in the proper installation place, and determine the screw holes in the holder based on the screw holes on the bracket.
- 7) Fix the bolt and screw it tight.

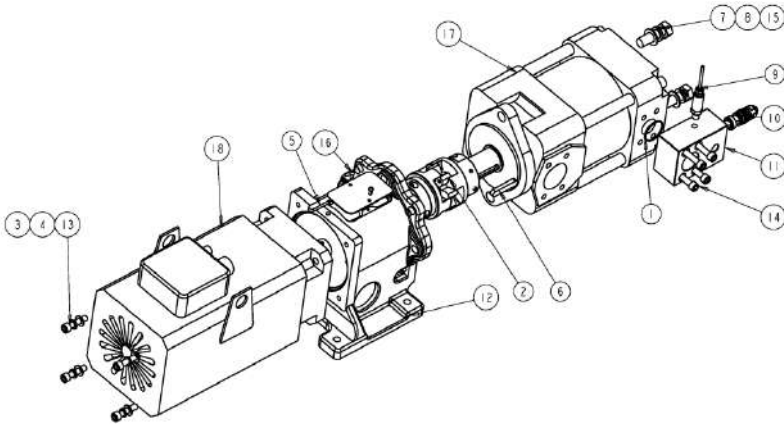

- ①O-type rubber seal ring; ②Coupling component;③Spring washer;④Flat washer;
 ⑤Motor flat key;⑥Oil pump flat key;⑦Spring ring;⑧Flat washer ring;⑨Pressure sensor;
 ⑩Assembled thread overflow valve;⑪Integrated block oil outlet plate;⑫Motor bracket;
 ⑬Hexagon socket cap screws;⑭Hexagon socket cap screws;⑮Hexagon bolt;
 ⑯Cross recessed round head screw;⑰Oil pump;⑱Servo motor

Chapter 4 Electrical Wiring

4.1 Wiring Precautions

	<ol style="list-style-type: none"> 1. Wiring can be done by professionals only as improper wiring may cause electric shock or fire. 2. MH800 series servo drive can be connected to industry-purpose power cables directly, namely transformer is not used for isolation. Users must use the breaker or fuse which is specific for wiring to prevent crossed electric shock from being generated by the servo system. 3. MH800 series servo drive does not carry built-in grounding protection circuit. Please configure with the current leakage breaker which carries overload and short circuit protection function, or the current leakage breaker used specifically for grounding protection which matches with the wiring-specific breaker.
NOTE	<ol style="list-style-type: none"> 1. It is recommended to adopt A, B or C connection mode (grounding resistor is below 10Ω) and single-point grounding is a must. If the servo motor and mechanical firmware insulates with each other, ground the servo motor directly. 2. Use thick cables for grounding wiring if possible (above 2.0mm²). 3. Currently, most of the leakage protection switches are electronic current leakage breaker, and the internal leakage detection and process circuit of different breaker brands vary enormously, which causes different anti-interference capacity of the breaker. It is recommended to use the leakage breaker with strong anti-interference capacity eg Chint. 4. Separate cables with strong electricity eg the power cable and servo motor input cable from the signal wires at a distance of more than 30cm. Do not put them or bundle them together. 5. The welding machine and electrical discharge machine cannot share the same power source, and even so, if there is high frequency generator nearby, connect noise filter to the input side of the power cable. 6. Users must install surge suppressor on the coils of the relay, solenoid and electromagnet contactor. 7. Install the input command device and noise filter near the servo unit to prevent mal-action caused by the noise. 8. The lead wire diameter, switch capacity and contactor capacity must be properly selected. Refer to Selection of switch, contactor and cable diameter.

※ Improper wiring may lead to system fault or potential physical injuries.

4.2 Selection of the Switch, Contactor and Cable Diameter

Drive Model	Power Inlet Disconnect Switch (A)	AC Contactor AC3 Rated Working Current (400V) (A)	Main Circuit				Control Circuit	
			Recommended Cable Cross-section(mm ²)			Max Cable Cross-section (mm ²)	Max Cable Cross-section (mm ²)	
			Input Cable	(+),(-), PB Cable	Output Cable			
SV-MH800-4R4-33-S00	40	25	2.5	2.5	2.5	16	1.5	
SV-MH800-5R5-33-S00	40	25	4	2.5	4	16	1.5	
SV-MH800-7R5-33-S00	63	32	10	4	10	25	1.5	
SV-MH800-011-33-S00	63	32	10	4	10	25	1.5	
SV-MH800-015-33-S00	63	50	10	6	10	25	1.5	
SV-MH800-018-33-S00	100	80	16	6	16	35	1.5	
SV-MH800-025-33-S00	100	80	16	6	16	35	1.5	
SV-MH800-030-33-S00	125	95	25	10	25	70	1.5	
SV-MH800-037-33-S00	160	115	25	10	25	70	1.5	
SV-MH800-045-33-S00	200	170	35	16	35	120	1.5	
SV-MH800-055-33-S00	200	170	35	16	35	120	1.5	
SV-MH800-075-33-S00	250	230	50	16	50	120	1.5	

- ※ The recommended cable dimension for main circuit can be used in the environment where the temperature is below 40°C and wiring distance is below 10m. If the environment temperature or wiring distance exceeds above limits, enlarge the cable dimension. It is recommended to use 600VIV plastic insulated cable;
- ※ Max cable cross-section means the max cross-section limited by the connection terminal dimension;
- ※ Brake resistor carries cables by itself, if it needs to be lengthened, select cables according to above table.

4.3 Terminal Layout

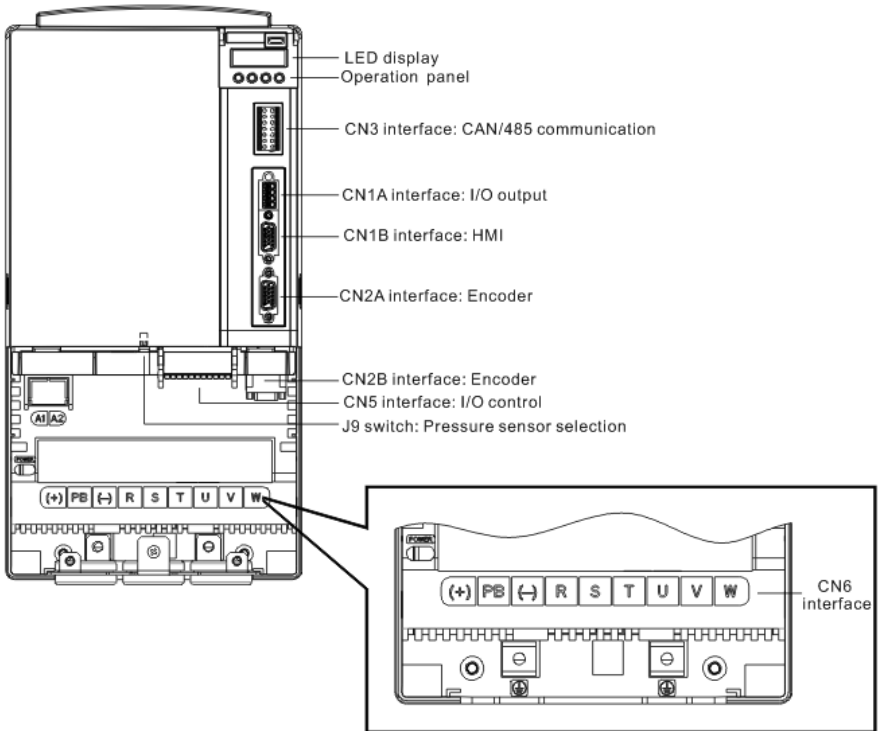

Terminal Name	Function
CN1A	I/O output signal connector
CN1B	External HMI connector
CN2A	Encoder (resolver) connector
CN2B	Encoder (resolver) connector
CN3	CAN/485 connector
CN4	Reserved
CN5	I/O control signal connector
CN6	Main circuit terminal

4.4 Standard Wiring

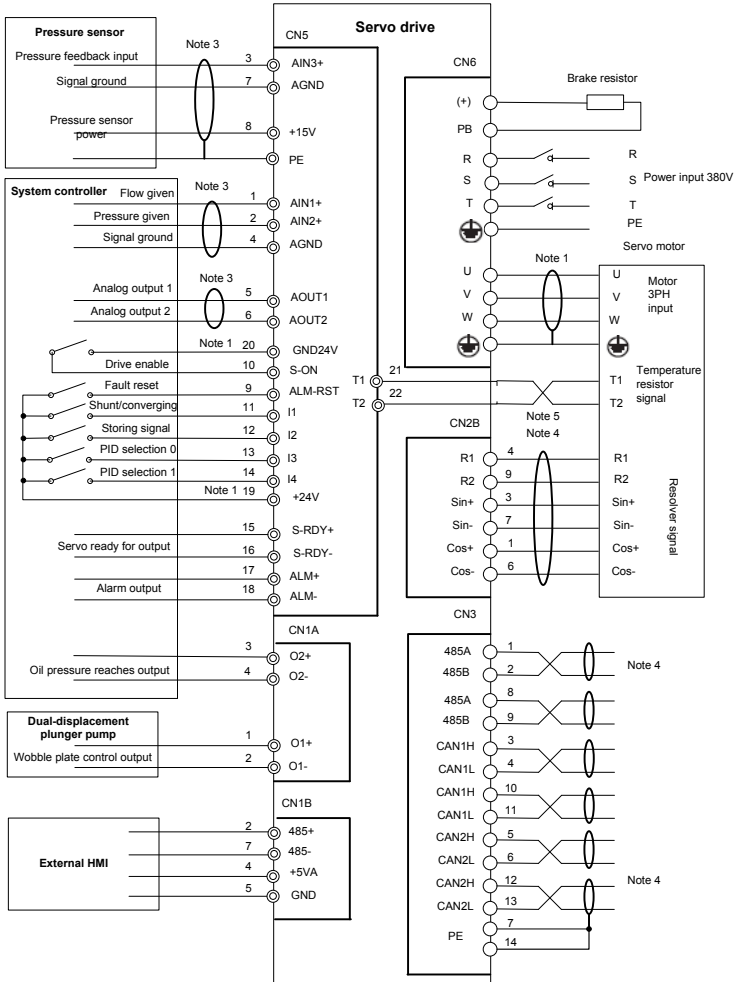

Note 1: In above wiring diagram, the digital input signal adopts system controller power drive, and the 24V power terminal on the CN5 connector should be connected to external power source. Users can use the internal pressure sensor power of the drive to jump to 15V side via J1 to connect +25V to 24V, or jump to 15V via J2 to connect AGND to GND24V. In default setting, J1 and J2 of the drive jump to 15V and the pressure sensor power is adopted.

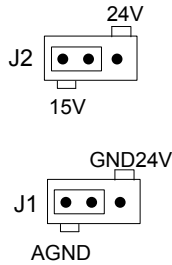

Note 2: The pressure sensor power of this drive is 15V, which accepts the pressure signal whose voltage signal is 0 – 10V or 1 – 15V (can be set by J9). Refer to [4.5](#) and [4.10.1](#) for details.

Note 3: It is recommended to adopt shielded cables for all the analog signal drive cables and motor 3PH input cables to prevent the drive from being impacted by interference.

Note 4: The resolver and communication cable must use twisted shielded pair with shielded layer being grounded. The both ends of the communication cable should be added with terminal matched resistor. The CAN communication signal connector of this drive carries built-in 10kΩ terminal resistor and the 485 communication signal connector carries built-in 1kΩ terminal resistor.

Note 5: It is recommended to use twisted pair to prevent the motor temperature sampling from being impacted by interference. This drive supports two kinds of sampling of motor temperature sensor, namely KTY84 and Pt1000. Users can select the temperature sensor type to be supported via setting motor temperature sensor parameters.

Note 6: AGND terminal can be connected to PE via J7 on the control board, or connected to capacitor via resistors. If the middle pin and PE pin of J7 is short connected, then this grounding mode is suitable for SV-MH800-4R4-33-S00, SV-MH800-5R5-33-S00, SV-MH800-7R5-33-S00, SV-MH800-011-33-S00, SV-MH800-015-33-S00 and SV-800-075-33-S00 drives.

Note 7: When analog output and digital output ports are used, sufficient output load resistor must be ensured to make the output current to be below specified value.

4.5 Instruction of Jumper Function

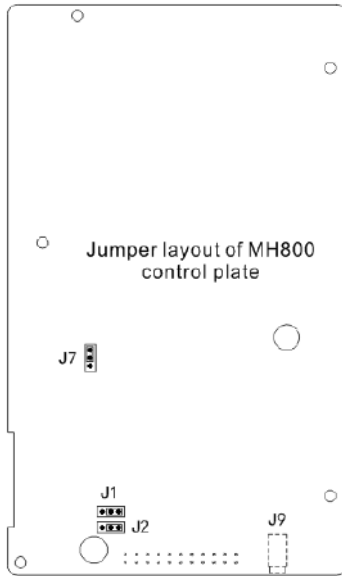

No.	Position	Function	Position	Function
J1		Digital input signal of Internal pressure sensor power drive; connect +15V to +24V		Digital input signal of external power drive; connect +15V to +24V
J2		Digital input signal of internal pressure sensor power drive; connect AGND to GND24V		Digital input signal of external power drive; disconnect AGND from GND24V
J7		Connect AGND directly to PE		AGND terminal connects to PE via resistors and capacitors
J9		0–10V output voltage pressure sensor		1–5V output voltage pressure sensor

4.6 Main Circuit Wiring

4.6.1 Name and Function of Main Circuit Terminal (CN6)

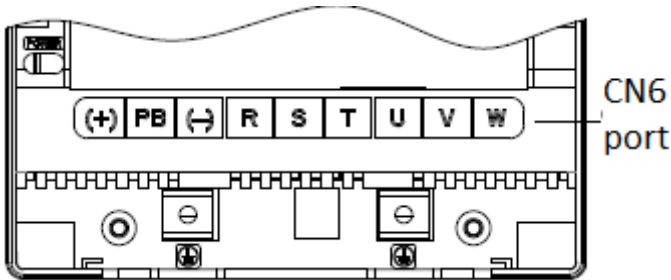

4.4kW – 15kW main circuit terminal diagram

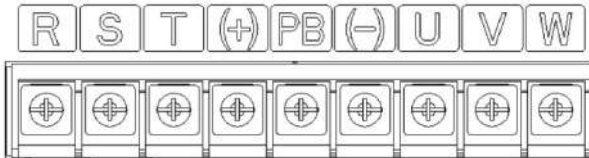

18kW – 25kW main circuit terminal diagram

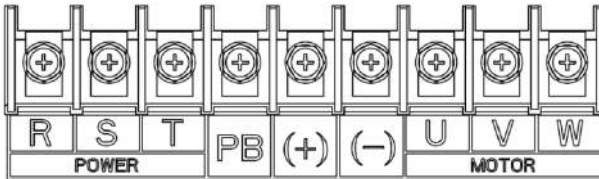

30kW – 37kW main circuit terminal diagram

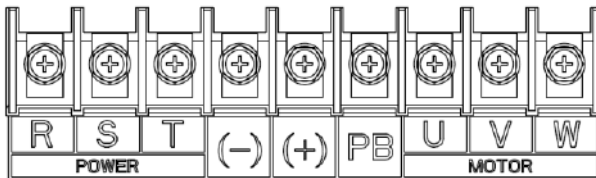

45kW – 55kW main circuit terminal diagram

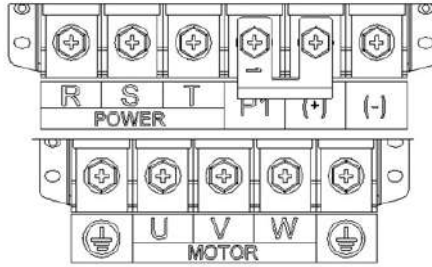

75kW main circuit terminal diagram

Terminal Name	Terminal Symbol	Function
Main circuit power input terminal	R, S, T	AC380V(-15%) – 440V(+10%) 47Hz – 63Hz
Servo motor connection terminal	U, V, W	Connect to servo motor
Grounding terminal	⊕	Connect to power grounding terminal and motor grounding terminal, carry out grounding
External brake resistor connection terminal(with PB terminal for models under 55kW)	(+), PB	Connect external brake resistor between (+) and PB
DC reactor terminal (P1 terminal is included in models above 75kW)	P1, (+)	P1 and(+) connect to external DC reactor

4.6.2 Name and Function of Resolver Signal Connector (CN2A, CN2B)

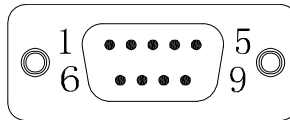

Signal Name	Code	Pin No.	Function
Resolver sine input+	Sin+	CN2-3	Resolver sine feedback signal
Resolver sine input-	Sin-	CN2-7	
Resolver cos input+	Cos+	CN2-1	Resolver cosine feedback signal
Resolver cos input-	Cos-	CN2-6	
Excitation signal+	R1	CN2-4	Resolver excitation signal
Excitation signal-	R2	CN2-9	

4.6.3 Motor Power Cable and Temperature Resistor Terminal (k series motor of our company)

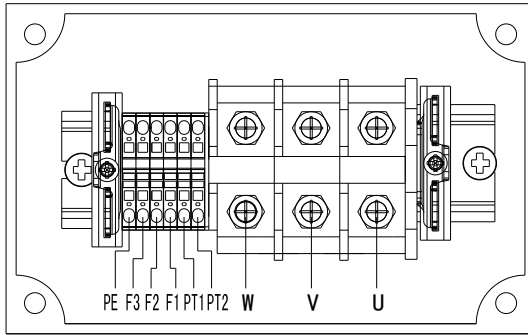

No.	Name	Definition
1	U	Motor 3PH input
2	V	
3	W	
4	PT1	Temperature resistor
5	PT2	
6	F1	Fan power 220V AC
7	F2	
9	PE	Grounding

4.6.4 Motor Resolver Terminal (k series motor of our company)

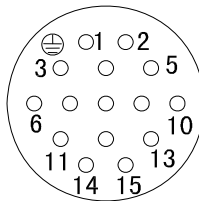

No.	Name	Definition
1	NC	Null
2	R1	Excitation signal+
3	R2	Excitation signal-
4	Sin+	Resolver sine output+
5	Sin-	Resolver sine output-
6	Cos+	Resolver cosine output+
7	Cos-	Resolver cosine output-
8 – 15	NC	Null

4.6.5 Motor Terminal (PHASE motor)

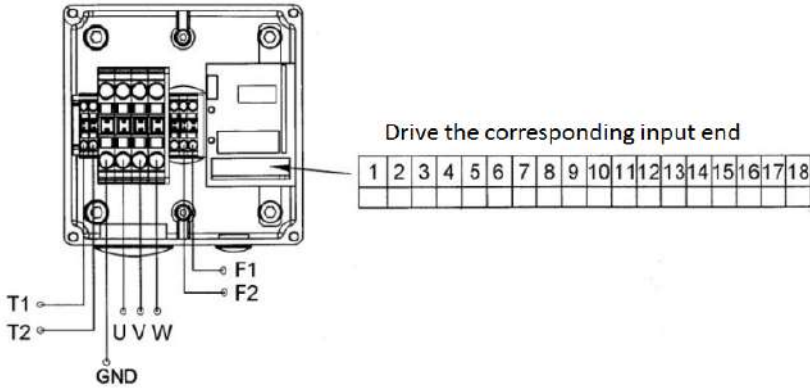

Terminal	Definition	Terminal	Definition
U	Motor 3PH input	1	<i>R</i> – revolver excitation input signal-
V		2	<i>R</i> + revolver excitation input signal+
W		3	<i>Sin</i> – revolver sine output signal-
GND	Motor grounding	4	<i>Sin</i> + revolver sine output signal+
T1	Motor internal temperature resistor	5	<i>Cos</i> – revolver cosine output signal-
T2		6	<i>Cos</i> + revolver cosine output signal+
F1	Motor internal cooling fan 220VAC power input	7 – 14	Null
F2		15	PTC+
17 – 18	Null	16	PTC-

4.6.6 Typical Main Circuit Wiring Instance

NOTE	1. Each cable insert port of the connector can be inserted with one cable only.
	2. Motor 3PH cable should use shielded cable, one end of which should connect to the ground wire of the drive and the other end should connect to the ground wire of the motor connector.
	3. The screws should be rotated to a proper degree of tightness to ensure smooth connection.

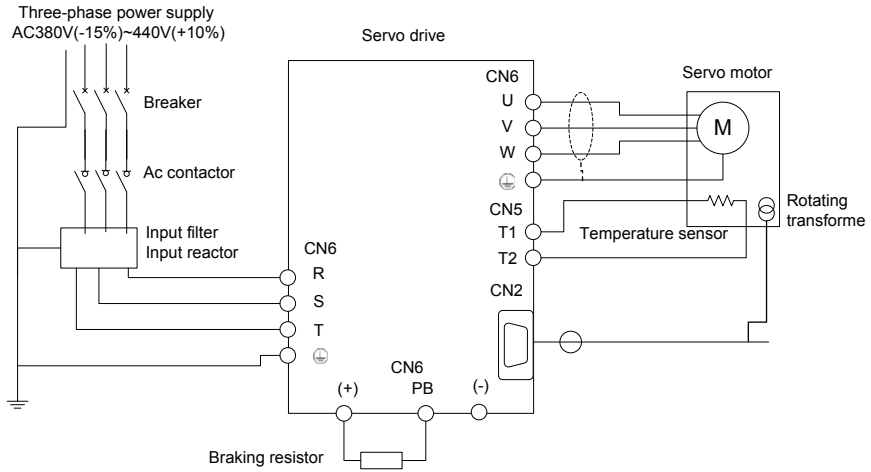

Main circuit wiring diagram for models below 55kW

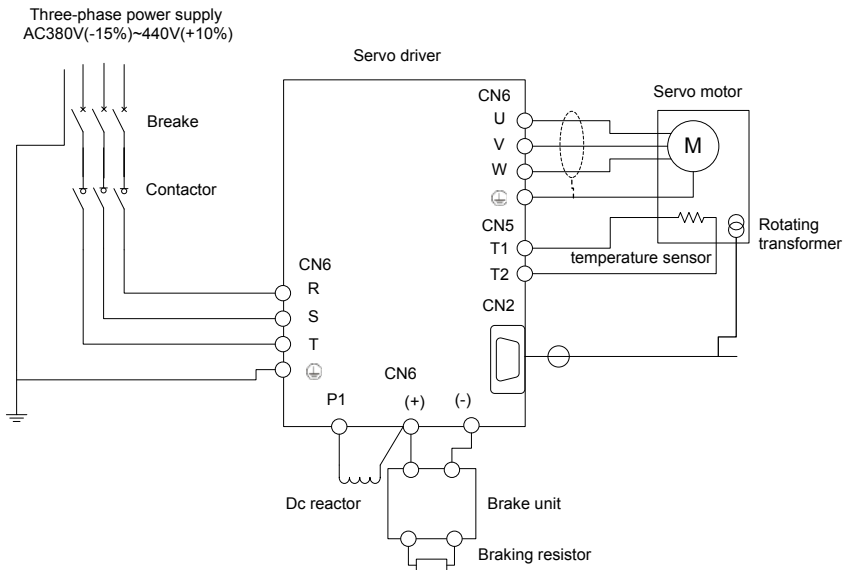

Main circuit wiring diagram for models above 75kW

4.6.7 Wiring Process of Main Circuit Terminals (CN6)

- 1) Connect input power cables to the input terminals R, S and T of the drive respectively, and connect the grounding conductor of the input power cable to any grounding screw (PE) of the drive, then

rotate the screw to a proper degree of tightness to ensure smooth connection;

2) Connect the 3PH input terminals W, V and U of the motor to the W, V and U terminals of the drive servo motor, then rotate the screw to a proper degree of tightness to ensure smooth connection. Connect the motor ground wire terminal to any grounding screw (PE) of the drive; connect the motor temperature resistor terminal to the T1 and T2 terminals of the drive and rotate the screw to a proper degree of tightness to ensure smooth connection; connect motor resolver connection terminal to the CN2 of the drive connector and screw tight the fixation screws;

3) Connect the two connection terminals of the brake resistor to the U+ and PB terminals of the drive, and rotate the screw to a proper degree of tightness to ensure smooth connection.

4.7 IO Signal Wiring

4.7.1 Name and Function of IO Signal Connector (CN5)

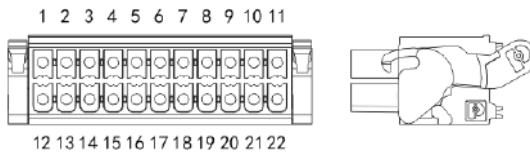

Definition of CN5 connector

Signal Name	Code	Pin No.	Function
Analog reference 1 input+	AIN1+	CN5-1	Flow command input; Input gain can be changed via LED and HM
Analog reference 2 input+	AIN2+	CN5-2	Pressure command input; Input gain can be changed via LED panel and HMI
Feedback input+	AIN3+	CN5-3	Pressure feedback input; Input gain can be changed via LED panel and HMI
Analog output 1	AOUT1	CN5-5	Monitor output, select internal parameter output via LED panel and HMI
Analog output 2	AOUT2	CN5-6	
Pressure sensor power	+15V	CN5-8	Voltage: +15VDC, ±5%(full scale range), 25°C output<100mA
Analog GND	AGND	CN5-4 CN5-7	
Fault reset signal	ALM-RST	CN5-9	Clear servo alarm state
Drive enable	S-ON	CN5-10	Motor changes to power-up state by releasing part of the grid block
Digital input 1	I1	CN5-11	I1: Shunt/converging selection (used in conjunction with multi-pump distribution operation function); converging at high level and shunt at low level I2: Storing signal input (used in conjunction with electronic backpressure function); high level injection
Digital input 2	I2	CN5-12	

Signal Name	Code	Pin No.	Function																									
			molding machine works in storing state and low level injection molding machine works in other states. Motor rotation direction signal (match with node flow loop) FWD for low level and REV for high level																									
Digital input 3	I3	CN5-13	Single pump pressure control stepwise PID parameter selection (four-step) <table border="1" style="margin-left: 20px;"> <tr> <td>I4</td> <td>I3</td> <td>KP no.</td> <td>KI no.</td> <td>KD no.</td> </tr> <tr> <td>low</td> <td>low</td> <td>0</td> <td>0</td> <td>0</td> </tr> <tr> <td>low</td> <td>high</td> <td>1</td> <td>1</td> <td>1</td> </tr> <tr> <td>high</td> <td>low</td> <td>2</td> <td>2</td> <td>2</td> </tr> <tr> <td>high</td> <td>high</td> <td>3</td> <td>3</td> <td>3</td> </tr> </table>	I4	I3	KP no.	KI no.	KD no.	low	low	0	0	0	low	high	1	1	1	high	low	2	2	2	high	high	3	3	3
I4	I3	KP no.	KI no.	KD no.																								
low	low	0	0	0																								
low	high	1	1	1																								
high	low	2	2	2																								
high	high	3	3	3																								
Digital input 4	I4	CN5-14	Multi-pump parallel pressure control stepwise PID parameter selection (four-step) <table border="1" style="margin-left: 20px;"> <tr> <td>I4</td> <td>I3</td> <td>KP no.</td> <td>KI no.</td> <td>KD no.</td> </tr> <tr> <td>low</td> <td>low</td> <td>0</td> <td>0</td> <td>0</td> </tr> <tr> <td>low</td> <td>high</td> <td>1</td> <td>1</td> <td>1</td> </tr> <tr> <td>high</td> <td>low</td> <td>2</td> <td>2</td> <td>2</td> </tr> <tr> <td>high</td> <td>high</td> <td>3</td> <td>3</td> <td>3</td> </tr> </table>	I4	I3	KP no.	KI no.	KD no.	low	low	0	0	0	low	high	1	1	1	high	low	2	2	2	high	high	3	3	3
I4	I3	KP no.	KI no.	KD no.																								
low	low	0	0	0																								
low	high	1	1	1																								
high	low	2	2	2																								
high	high	3	3	3																								
Servo ready+ Servo ready-	S-RDY+ S-RDY-	CN5-15 CN5-16	Conducting when no servo alarm occurred under the condition that the drive enable end is LOW and main circuit is powered up.																									
Alarm output+ Alarm output-	ALM+ ALM-	CN5-17 CN5-18	Conducting when abnormality is detected, opto-coupler output, max voltage: DC30V; max current: DC50mA																									
Control power input used for digital signal	+24V	CN5-19	+24V power is prepared by the user. Actable voltage range: +8V – +25V																									
Digital signal GND	GND24V	CN5-20																										
Motor temperature sensor 1	T1	CN5-21	There is no differentiation of positive and negative pole for motor temperature sensor terminals (T1, T2).																									
Motor temperature sensor 2	T2	CN5-22	The drive supports motor temperature sensor (resistor) in KTY84-130 and PT1000 type, which can be changed via LED panel and HMI. The hardware circuit will select corresponding temperature sensor detection circuit automatically.																									

4.7.2 I/O Output Signal Connector Terminal (CN1A)

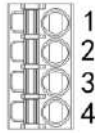

Definition of CN1A connector

Signal Name	Code	Pin No.	Function
Digital output 1	O1+ O1-	CN1A-1 CN 1A-2	Wobble plate output signal (used in match with dual-displacement pump wobble plate control function) Conducting small displacement, disconnecting large displacement Relay output contact capacity: 3A /250VAC 1A/30VDC
Digital output 2	O2+ O2-	CN1A-3 CN1A-4	Conducting when oil pressure reaches output and feedback pressure reaches a certain percentage of the reference pressure, the percentage is settable. Opto-coupler output, max voltage: DC30V, max current: DC50mA

4.7.3 Typical Wiring Diagram of Control Signal

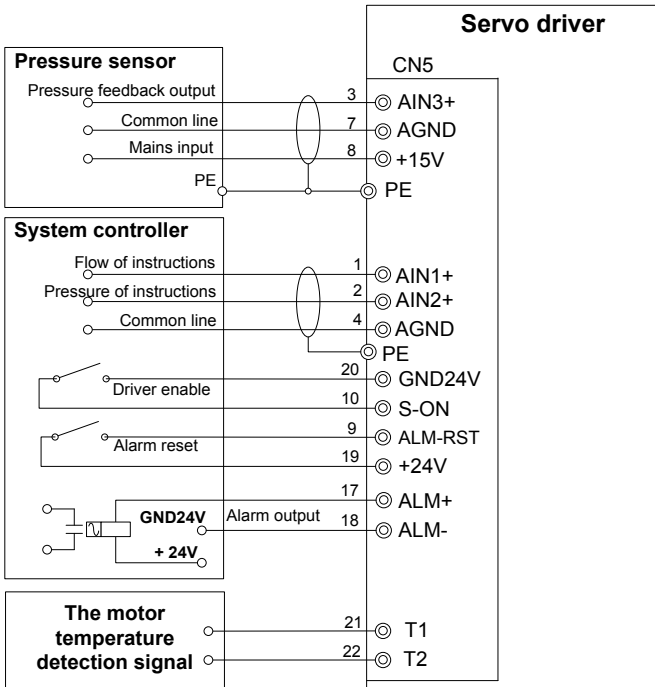

4.8 CAN/485 Connector Terminal (CN3)

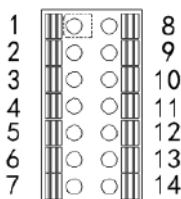

Definition of CN3 connector

The drive carries two CAN communication interfaces and one 485 communication interface, in which the 485 communication interface supports standard Modbus RTU communication protocol. 485 communication connects to 1k Ω terminal resistor internally.

CAN communication port 1 supports standard CANOPEN communication protocol and connects to 10k Ω terminal resistor internally.

CAN communication port 2 is the CAN communication interface between multiple drives of multi-pump parallel system and is the specific CAN communication port for PC debugging software SCM. CAN communication port 2 connects to 10k Ω terminal resistor internally.

Signal Name	Code	Pin No.	Function
RS485 communication port	RS485_A RS485_B	CN3-1,8 CN3-2,9	Half-duplex, supportable baud rate: 9600bps,19200bps,38400 bps,57600bps,115200bps(9600bps by default)
CAN communication port 1	CAN1H CAN1L	CN3-3,10 CN3-4,11	CAN protocol standard signal, adopt optical coupling isolation, can be connected to CAN-BUS directly.
CAN communication port 2	CAN2H CAN2L	CN3-5,12 CN3-6,13	
Case ground	PE	CN3-7,14	Connect to the case

4.9 Name and Function of Serial Communication Signal Connector (CN1B)

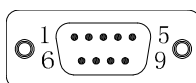

The serial communication connector is the external HMI common connector of our company. If external HMI needs to be used for commissioning, insert the connection wire of external HMI.

Signal Name	Code	Pin No.	Function
RS485 communication interface	RS485_A RS485_B	CN1B-2 CN1B-7	Half-duplex, max communication rate: 115200bits/s(19200 bits/s by default)

Communication power	+5VA	CN1B-4,8	Max output current 200mA, precision $\pm 5\%$
GND	GND_5VA	CN1B-5,9	

4.10 Interface Circuit

4.10.1 Analog Input Circuit Interfaces

The analog input circuit is as below:

- 1) Instruction for terminal 1 (flow reference) and 2 (pressure reference) of CN5 connector.

Input impedance of voltage input mode: about 20k Ω , max allowed voltage is 15V.

- 2) Instruction for terminal 3 of CN5 connector (feedback input).

Analog signal is oil pressure feedback signal, users can choose 0 – 10V or 1 – 5V output pressure sensor via toggle switch J9. ON side is 1 – 5V while OFF side is 10V, the default is 10V.

Input impedance: about 100k Ω , max allowed voltage is 15V.

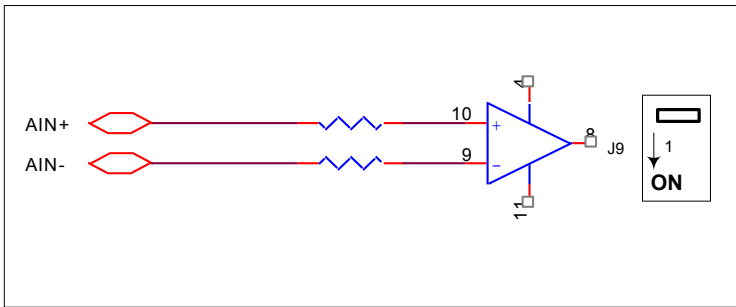

4.11 Digital Input Circuit Interface

- 1) Instructions for terminal 9 – 14 of CN5 connector are shown below:

Users can select active-high circuit or (JP2, PJ4 disconnected, JP1, JP3 short connected) active-low circuit input mode via jumpers (JP2, JP4 short connected; JP1, JP3 disconnected), S-ON connected as active-low circuit mode, while I1~I4 connected as active-high circuit mode. If users need active-low circuit mode, inform the manufacturer to modify the interface logic, which is shown below:

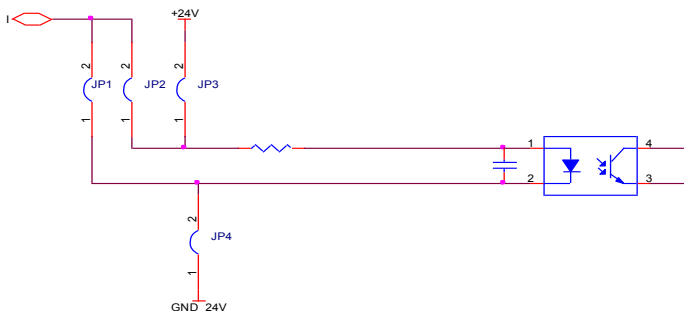

4.11.1 Digital Output Circuit Interfaces

Instructions for 15 – 18 terminal of CN5 connector and the digital output terminal 3 and 4 of CN1A connector: digital output signal (S_RDY, ALM, COIN, O2) is opto-coupler open collector output. Please use opto-coupler circuit, relay circuit or bus receiver circuit for receiving, below is the interface circuit.

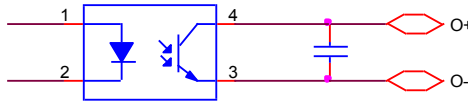

- Max voltage: DC30V
- Max current: DC50mA

2) Instruction for relay output circuit:

Instruction for digital output terminal 1 and 2 of CN1A connector: digital output signal (O1) is relay output. Below is interface circuit.

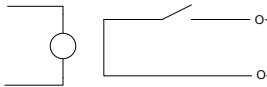

3) Analog output circuit is as below:

Instruction for terminal 5 and 6 (analog output) of CN5 connector: Analog output signal (AOUT1, AOUT2) is operational amplifier output which forms an output circuit with AGND. Users can select internal parameter output via LED panel, HMI and SCM, the default setting is AOUT1 pressure output and AOUT2 motor flow output. Below is the interface circuit.

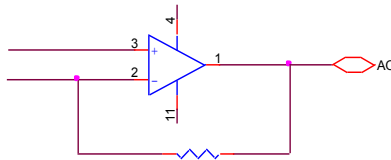

- Output precision: 10-bit D/A
- Voltage range: 0 – 10V
- Max current: DC10mA

Chapter 5 Display and Function

5.1 External HMI Display and Operation

5.1.1 HMI Panel Interface Instruction

Control panel is divided into LCD display area and keypad area. LCD adopts 5.7-inch 320x240 screen and keypad area is comprised of 10 buttons which are divided into operation key area, direction key area and setup key area as shown below.

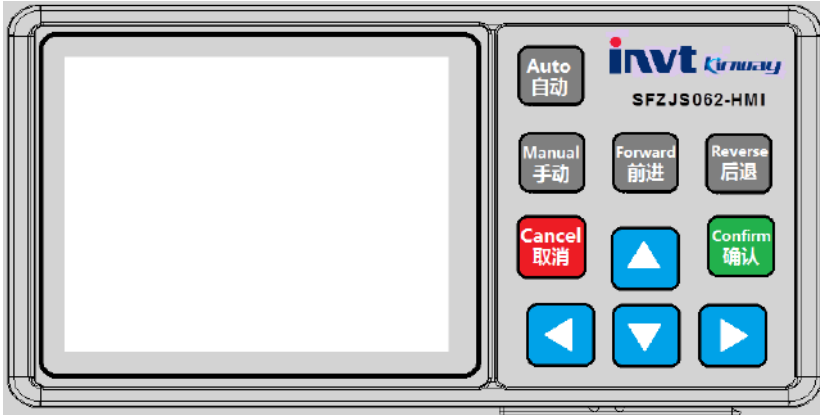

The layout diagram of LCD area display is shown below:

The menu bar	Monito	Setting	Tuning
Parameters of the display area			
The system status bar	System state: Speed:	Torque:	Presure: Location:

Menu bar: Display the menu options under different states, the selected menu option is displayed in blue letters on white background while other menu options are displayed in white letters on blue background. The menu bar can display 3 menu options simultaneously at most, and the options can be selected via direction keys.





Parameter display area: Display the parameter name, value and unit of the selected menu.

System state bar: Display current system state and torque, speed and resolver value. The unit is default value (torque: nm, speed: r/m).







The content of menu bar and parameter display area vary with the key operations. The content of system state bar varies with the system operation state.

5.2 Function of Control Panel Keys



5.2.1 Key Function of Operation Key Area

	Press this button to switch between “enable” and “disable”.
	Reserved
	Under commissioning menu, if “jogging enable” is enabled, press forward key and the motor will rotate forward according to the set jogging speed.
	Under commissioning menu, if “jogging enable” is enabled, press backward key and the motor will rotate backward according to the set jogging speed.

5.2.2 Key Function in Direction Key Area

	<ol style="list-style-type: none"> 1. When switching the menus, press this key to select the menu rightward; 2. When setting parameters, press this key to control the selected block “” to jump rightward between “save”/“cancel” and parameter numbers.
	<ol style="list-style-type: none"> 1. When switching the menus, press this key to select the menu leftward; 2. When setting parameters, press this key to control the selected block “” to jump leftward between “save”/“cancel” and parameter numbers.
	<ol style="list-style-type: none"> 1. When checking parameters, press this key to select corresponding parameter upward. 2. When setting parameters, press this key to change the selected number in plus-one mode and realize carry shift.
	<ol style="list-style-type: none"> 1. When checking parameters, press this key to select corresponding parameters in downward mode. 2. When setting parameters, press this key to change the selected number in minus-one mode and realize decomposition shift.

5.2.3 Key Function of Setup Key Area

	<ol style="list-style-type: none"> 1. Press this key to enter parameter setup from parameter checking, or realize disable/enable function. 2. When selecting “save”/“cancel” virtual button, press this key to save/cancel parameter setup.
	<ol style="list-style-type: none"> 1. Press this key to return from parameter setup to parameter checking.

5.3 External HMI Function

When HMI is connected to the drive and powered up, the screen will pop out initialization process, and after initialization is done, users can use the keys to operate HMI.

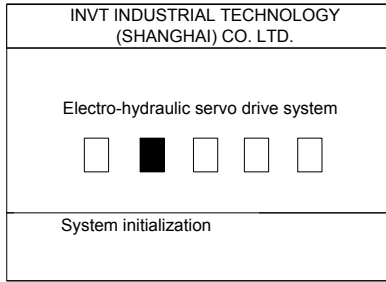

Reference parameter list, users can use and keys to switch menu bars and select “monitor”, “set”, “debugging”, “multi-pump” or “parameter programming” menu bars, the selected menu bar will be displayed in highlighted cursor. Stop the highlighted cursor at the desired parameter.

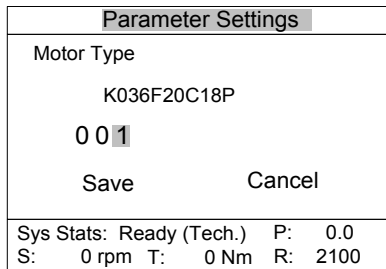

Monito	Setting	Tuning
Drive Type		CT-7501-A-0
Motor Type		U1004F.15.3
Pump Type		SETTIMA 28mL/r
P. Sensor Zero		
P. Cal. Mode		Linear
Q. Cal. Mode		Linear
Sys Stats: Ready (Tech.)		P: 0.0
S: 0	T: 0	R: 2100

After parameter is selected by highlighted cursor, press key to enter parameter modification interface:



Use and keys to stop the highlighted cursor at the currently selected motor and select motor model via and key;

Parameter Settings	
Motor Type	
K036F20C18P	
0 0 1	
Save	Cancel
Sys Stats: Ready (Tech.) P: 0.0	
S: 0 rpm T: 0 Nm R: 2100	

Then stop the highlighted cursor at “save” via  and  key, and press  key to save and exit to setup menu bar, HMI will transmit current parameters to the drive.

Some debugging parameters differ from the setup parameters eg when diagnosis enable parameter is selected by highlighted cursor, press  key to modify the parameter content directly.

5.3.1 Monitoring Menu List

Menu No.	Menu Name	Meaning	Parameter Range	Unit
1st screen				
0	Flow reference+ Analog signal voltage	Flow reference value and voltage value of flow reference analog signal	[0,2400.0] [0,10.00]	L/min V
1	Pressure reference+ Analog signal voltage	Pressure reference value and voltage value of pressure reference analog signal	[0,250.0] [0,10.00]	bar V
2	System fault	System fault alarm (can display multiple faults that occurred simultaneously)	Refer to 10.1	
3	Motor current	Valid value of motor winding current	[0,900.0]	A
4	AC voltage	AC input voltage	[0,500]	Vrms
5	DC voltage	DC bus voltage	[0,800]	V
2nd screen				
6	Torque limit	Real-time torque output capacity of the system	[0,1800]	Nm
7	Motor temperature	Motor winding temperature	[-52,244]	°C
8	Drive temperature	IGBT module temperature	[-46,244]	°C
9	Environment temperature	Air temperature of the drive	[-18,114]	°C
10	Machine material	The drive no. which can be modified by the user	[undefined, 1,999]	
11	Max system pressure	Max pressure for oil pump to discharge hydraulic pressure oil	[0,250.0]	bar

Menu No.	Menu Name	Meaning	Parameter Range	Unit
3rd screen				
12	Max system flow	Max flow for the oil pump to discharge hydraulic pressure oil	[0,2400.0]	L/min
13	Power	Mechanical power outputted by the motor	[0,327.67]	kW
14	Present PID step	The drive supports usage of multi-step single-pump /multi-pump pressure to control PID function under different working conditions. This menu displays the single pump or multi-pump pressure currently used to control the PID step no.	[0,3]	
15	Converging type	Select the working mode of the drive under multi-pump operation	0: single pump; 1: Composite; 2: Multi-pump; 3: Multi-mode	
16	Software version	Drive software version		
17	Interface version	HMI software version		
4th screen				
18	Operation time	Accumulated running time of the drive	[0,99] [0,364] [0,23] [0,59]	Year Day Hour Minute
19			[0,9.99]	

5.3.2 Setup Menu List

Menu No.	Menu Name	Meaning	Parameter Range	Default Value	Unit
1st screen					
0	Drive model selection	Drive model	Refer to drive model list in 5.5.5	The same with drive label	
1	Motor model selection	Motor model	Refer to motor model list in 5.5.5	U1013F.17.3	
2	Pump selection	Oil pump model	Refer to oil pump model list in 5.5.5	PUMP 100 mL/r	
3	Pressure feedback zero position	Pressure sensor zero position offset can be	Pressure feedback zero position	The default pressure	

Menu No.	Menu Name	Meaning	Parameter Range	Default Value	Unit
	calibration	removed by pressure feedback zero position calibration	calibration	feedback zero position offset is 0V	
4	Pressure calibration mode	Calibration mode of pressure reference analog signal	Linear pressure calibration Polyline pressure calibration	Linear pressure calibration	
5	Flow calibration mode	Calibration mode of flow reference analog signal	Linear flow calibration Polyline flow calibration	Linear flow calibration	
2nd screen					
6	Linear/polyline pressure calibration	Used to select pressure linear calibration or polyline calibration. During calibrating, the drive enable should be disabled. During linear calibration, set the injection molding machine controller to provide zero position and full range voltage. Polyline calibration should be carried out when the pressure reference value of injection molding machine system drive is the same with that of the polyline point.	Under linear calibration mode: Zero position Full range Under polyline calibration mode: Polyline point 0 Polyline point 1 Polyline point 2 Polyline point 3 Polyline point 4 Polyline point 5 Polyline point 6 Polyline point 7 Polyline point 8 Polyline point 9 Polyline point 10 Polyline point 11 Polyline point 12	Zero position	
7	Linear/polyline flow calibration	Used to select flow linear calibration or polyline calibration. During calibrating, the drive enable should be disabled. During linear calibration, set the injection molding machine	Under linear calibration mode: Zero position Full range Under polyline calibration mode: Polyline point 0	Zero position	

Menu No.	Menu Name	Meaning	Parameter Range	Default Value	Unit
		controller to provide zero position and full range flow. Polyline calibration should be carried out when the flow reference value of injection molding machine system drive is the same with that of the polyline point.	Polyline point 1 Polyline point 2 Polyline point 3 Polyline point 4 Polyline point 5 Polyline point 6 Polyline point 7 Polyline point 8 Polyline point 9 Polyline point 10 Polyline point 11 Polyline point 12		
8	Pressure filter	Calculation times of the average filter of pressure reference sampling value	[1,32]	1	
9	Flow filter	Calculation times of the average filter of flow reference sampling value	[1,32]	1	
10	Pressure full range	Set the pressure full range of the node	[1,250]	175	bar
11	Flow full range	Set the flow full range of the node	[1,2400]	200	L/min
3rd screen					
12	Max flow	Set the max flow value of the node	[0,2400]	200	L/min
13	Max pressure	Set the max pressure value of the node	[0,250]	180	bar
14	Flow reference zero position deadzone	Small signal vibration of flow reference analog signal	[0,100.00]	0.5	%
15	Pressure reference zero position deadzone	Pressure reference analog signal small signal control	[0,100.00]	0.5	%
16	Pressure feedback zero position deadzone	Pressure feedback analog input signal small signal control	[0,100.00]	0	%
17	Pressure full range voltage	Corresponding DC voltage when pressure reference input reaches full range	[0,11.00]	10.00	V

Menu No.	Menu Name	Meaning	Parameter Range	Default Value	Unit
4th screen					
18	Flow full range voltage	Corresponding DC voltage when flow reference input reaches full range	[0,11.00]	10.00	
19	Pressure feedback gain	Enlargement multiple of pressure feedback signal	[0,32767]	8182	
20	Pressure reference rising slope	Step length of the rising of pressure reference per ms	[0,32767]	16000	0.0076
21	Pressure reference declining slope	Step length of the declining of pressure reference per ms	[0,32767]	16000	29 bar/ms
22	Flow reference rising slope	Step length of the rising of pressure reference per ms	[0,32767]	16000	"0.073 24L/mi n" per second
23	Flow reference declining slope	Step length of the declining of pressure reference per ms	[0,32767]	16000	
5th screen					
24	Pressure multi-step PID enable	Used to select whether to use multi-step mode for pressure PID parameter	0: Disable 1: Enable	0: Disable	
25	Pressure proportional gain 0	The 0 th step of proportional parameter of pressure PID control	[0,32767]	13000	
26	Pressure integral gain 0	The 0 th step of integral parameter of pressure PID control	[0,32767]	100	
27	Pressure differential gain 0	The 0 th step of differential parameter of pressure PID control	[0,32767]	0	
28	Pressure proportional gain 1	The 1 st step of proportional parameter of pressure PID control	[0,32767]	13000	
29	Pressure integral gain 1	The 1 st step of integral parameter of pressure PID control	[0,32767]	100	
6th screen					
30	Pressure differential gain 1	The 1 st step of differential parameter of pressure PID control	[0,32767]	0	

Menu No.	Menu Name	Meaning	Parameter Range	Default Value	Unit
		control			
31	Pressure proportional gain 2	The 2 nd step of proportional parameter of pressure PID control	[0,32767]	13000	
32	Pressure integral gain 2	The 2 nd step of integral parameter of pressure PID control	[0,32767]	100	
33	Pressure differential gain 2	The 2 nd step of differential parameter of pressure PID control	[0,32767]	0	
34	Pressure proportional gain 3	The 3 rd step of proportional parameter of pressure PID control	[0,32767]	13000	
35	Pressure integral gain 3	The 3 rd step of integral parameter of pressure PID control	[0,32767]	100	
7th screen					
36	Pressure differential gain 3	The 3 rd step of differential parameter of pressure PID control	[0,32767]	0	
37	Speed gain switching 0	When below speed gain switching 0, speed loop PI parameter is speed proportional gain, speed integral gain; when above speed gain switching 1, speed loop PI parameter is speed proportional gain 1, speed integral gain 1. Between these two, PI parameter is obtained by the linear change of two groups of parameters.	[0,6000]	5994	rpm
38	Speed gain switching 1	When below speed gain switching 0, speed loop PI parameter is speed proportional gain, speed integral gain; when above speed gain switching 1, speed loop PI parameter is speed proportional gain 1, speed integral gain 1. Between these two, PI parameter is obtained by the linear change of two groups of parameters.	[0,6000]	5994	rpm
39	Speed multi-step PI enable	Used to select whether to use multi-step mode for speed PI parameter	0: Disable 1: Enable	0: Disable	
40	Speed proportional gain 0	The 0 th step of proportional parameter of speed PI	[0,32767]	7000	

Menu No.	Menu Name	Meaning	Parameter Range	Default Value	Unit
		control			
41	Speed integral gain 0	The 0 th step of integral parameter of speed PI control	[0,32767]	170	
41	Motor rotation direction	Set motor rotation direction	FWD REV	FWD	
8th screen					
42	High speed speed proportional gain	Proportional parameter of high speed speed PI control	[0,32767]	7000	
43	High speed speed integral gain	Integral parameter of high speed speed PI control	[0,32767]	140	
44	Speed proportional gain 1	The 1 st step of proportional parameter of speed PI control	[0,32767]	7000	
45	Speed integral gain 1	The 1 st step of integral parameter of speed PI control	[0,32767]	140	
46	Speed proportional gain 2	The 2 nd step of proportional parameter of speed PI control	[0,32767]	7000	
47	Speed integral gain 2	The 2 nd step of integral parameter of speed PI control	[0,32767]	140	
9th screen					
48	Speed proportional gain 3	The 3 rd step of proportional parameter of speed PI control	[0,32767]	7000	
49	Speed integral gain 3	The 3 rd step of integral parameter of speed PI control	[0,32767]	140	
50	Pump displacement (reset)	Oil pump displacement per revolution	[0,32767]	100	mL/rev
51	Pump leakage (reset)	The ratio of oil pump discharge displacement and outlet pressure	[0,100.00]	0	L/min /bar
52	Pump REV speed limit	Max REV speed of oil pump	[0,-6000]	-300	rpm
53	Max motor speed	Max motor speed in FWD and REV rotation	[0,6000]	2200	rpm

Menu No.	Menu Name	Meaning	Parameter Range	Default Value	Unit
10th screen					
54	DC voltage calibration	Use the actually detected DC bus voltage to calibrate the drive DC voltage	[0,800]	Null	V
55	AC voltage calibration	Use the actually detected AC input voltage to calibrate the drive AC voltage	[0,800]	Null	V
56	Base flow enable	Used to set whether the oil pressure control is base flow mode	Without base flow With base flow	Without base flow	
57	Base flow pressure	If the system is in base flow control mode, this parameter is used to set the target pressure value of the base flow	[250.0]	3.0	bar
58	Flow value of base flow	If the system is in base flow control mode, this parameter is used to set the flow value used to make the system reach base flow pressure value	[327.6]	1.0	L/min
59	Overshoot limit value	When the gap between oil pump feedback pressure and reference pressure exceeds this set value, the motor will decelerate rapidly to limit the pressure overshoot	[5,50]	30	bar
11th screen					
60	Motor rotation direction	Set the motor rotation direction	FWD REV	FWD	
61	Resolver direction	Set the resolver direction	FWD REV	FWD	
62	Backpressure mode	Select the control mode of backpressure storing of injection molding machine	Manual Automatic	Manual	
63	Pressure sensor model selection	Pressure sensor type	5v 10v	10v	

Menu No.	Menu Name	Meaning	Parameter Range	Default Value	Unit
			400bar		
64	Plunger pump model selection	Select displacement type	Single displacement Dual displacement	Single displacement	
65	Plunger pump displacement ratio	Displacement ratio of big and small dual-displacement pump	[0,100.0]	20	%
12th screen					
66	Wobble plate switching pressure threshold	Wobble plate switches to the feedback pressure threshold value of small displacement	[0,250.0]	195	bar
67	Displacement switching mode	0: Over-pressure; 1: Over-pressure occurred during holding pressure		0: Over-pressure	
68	Displacement pressure judging delay	When the system meets the wobble plate switching condition and the duration exceeds the displacement pressure judging delay, wobble plate will start switching	[0,32767]	100	ms
69	Displacement switching rising delay	The time from when the drive wobble plate control digital output port converts to disconnection to when the pump displacement increases to large displacement value	[0,32767]	10	ms
70	Displacement switching declining delay	The time from when the drive wobble plate control digital output port converts to connection to when the pump displacement declines to large displacement value	[0,32767]	10	ms
71	Speed switching upper limit	Speed threshold value of wobble plate switching to	[0,6000]	1200	rpm

Menu No.	Menu Name	Meaning	Parameter Range	Default Value	Unit
		large displacement			
13rd screen					
72	Speed switching lower limit	Speed threshold value of wobble plate switching to small displacement	[0,6000]	200	rpm
73	O2 connection pressure coefficient	When the ratio of feedback pressure and reference pressure exceeds this coefficient, the digital output O2 is connected	[0,100.00]	90	%
74	Negative torque control	When negative torque control is enabled, motor negative torque amplitude is zero	0: Disable 1: Enable	0: Disable	
75	Rated motor voltage	During motor autotuning, input motor nameplate parameter	[0,800]	334	V
76	Rated motor current	During motor autotuning, input motor nameplate parameter	[0,900]	64	A
77	Rated motor speed	During motor autotuning, input motor nameplate parameter	[0,6000]	1467	rpm
14th screen					
78	Rated motor frequency	During motor autotuning, input motor nameplate parameter	[0,600.0]	97.8	Hz
79	Rated motor counter-emf	During motor autotuning, input motor nameplate parameter	[0,800.0]	183.1	V/Krpm
80	Motor temperature sensor	Select according to the motor sensor type	0: NTC 1: PTC 2: KTY84 3: PT1000	2: KTY84	
81	Upper limit of reverse torque	Proportional coefficient of max motor reverse torque reduction	[0,100]	100	%
82	Oil circuit pressure	The pressure discharge	0: Normal oil circuit	0: Normal oil	

Menu No.	Menu Name	Meaning	Parameter Range	Default Value	Unit
	discharge mode	mode of system high pressure oil, adopt oil pump reversion (normal oil circuit) or electromagnet overflow valve (valve pressure discharge oil circuit)	1: Valve pressure discharge oil circuit	circuit	
83	Advanced parameter operation enable	When advanced parameter is enabled, the setup parameters larger than no. 66 of HMI can be displayed and set; when it is disabled, only those smaller than no.65 of HMI can be displayed	11111: Disable 99999: Enable Other value: No action	0	
15th screen					
84	Pressure sensor range	Set the pressure range of pressure sensor	[0,250]	250	bar
85	Pressure feedback fine tuning parameter	Adjust pressure feedback gain coefficient via this parameter	[50,200]	100	%
86	Min value of flow reference	Set the min value of flow analog input	[0,2400.0]	0	L/Min
87	Over-modulation enable	After over modulation is enabled, the output voltage modulation ratio of the drive can reach 105% to the max	Disable Enable	Disable	
88	Over modulation ratio	Set the modulation ratio of the max output voltage of the drive	[1.00,1.05]	1.05	%
89	Carrier frequency	Select the carrier frequency of the drive	[4,5,8,10,3,2]	3	kHz
16th screen					
90	Speed feedback filter mode	Select speed operation mode	0: Moving averages 1: Least squares 2 – 3: Reserved	0: Moving averages	
91	Speed control rigidity	1: Corresponding speed loop speed is the lowest;	[1,14]	9	

Menu No.	Menu Name	Meaning	Parameter Range	Default Value	Unit
		14: Corresponding speed loop speed is the fastest			
92	Motor inertia	Set automatically during motor model selection	[0,0.655]	0.018	KgM ²
93	Motor autotuning direction	Default value: 0: FWD	0: FWD 1: REV	0: FWD	
94	Rated drive power		[0.00, 327.67]	4R4→4.00 5R5→5.50 7R5→7.50 011→11.00 015→15.00 075→75.00	Kw
95	Rated drive current	Set automatically during motor model selection	[0,900]	4R4→18.4 5R5→25.5 7R5→31.1 011→36.8 015→42.4 075→220.6	A
17th screen					
96	Torque limit	Max torque of motor electromotion and power generation	[0,1800]	425	Nm
97	Disturbance compensation gain	Output torque coefficient of pressure disturbance compensation function	[0,200]	0	%
98	Disturbance compensation filter frequency	Filter frequency setup	[0,5000]	500	Hz
99	Disturbance compensation lag cycle	Output torque lag cycle of pressure disturbance compensation function	[0,15]	5	Cycle (Speed loop cycle)
100	PWM voltage compensation	A kind of PWM generation mode used to reduce the electromagnet interference of analog signal	0: Disable 1: Enable	0: Disable	
101	Pump stuck detection	Gear pump stuck detection and reset function	0: Disable 1: Enable	1: Enable	

Menu No.	Menu Name	Meaning	Parameter Range	Default Value	Unit
18th screen					
102	Speed integral torque boost	Speed integral gain parameter increases based on this parameter according to the ratio of feedback torque and max motor torque	[0,1000]	0	%
103	Valve pressure discharge starting speed	Threshold of the starting speed of electromagnet overflow valve	[300,-300]	-1	rpm
104	Valve pressure discharge starting pressure	Threshold of the starting pressure of electromagnet overflow valve	[0,500]	20	bar
105	Valve pressure discharge closing pressure	Electromagnet overflow valve is closed when feedback pressure is lower than this value	[0,500]	1	bar
106	Cut-in speed of pressure-hold feedforward	Judge whether the system enters the upper speed limit of pressure-hold state	[0,6000]	100	rpm
107	Cut-in pressure of pressure-hold feedforward	Judge whether the system enters the lower pressure limit of pressure-hold state	[0,500]	200	bar
19th screen					
108	Pressure-hold feedforward gain	Improve this parameter can improve the stability of holding pressure	[0,32767]	0	
109	PID terminal usage mode	Input terminal function setup	0: Common 1: Specific for casting machine	0	
110	ALM-RST input selection		0: No function 1: Fault reset	1: Fault reset	
111	S-ON input selection		2: Drive enable 3:	2: Drive enable	
112	I1 input selection		Shunt/converging selection 4: Storing signal input	3: Shunt/converging selection	

Menu No.	Menu Name	Meaning	Parameter Range	Default Value	Unit
113	I2 input selection		5: Motor rotation direction 6: PID terminal 1 7: PID terminal 2 8: PID terminal 3 9: PID terminal 4	4: Storing signal input	
20th screen					
114	I3 input selection	Input terminal function setup	10: Trigger mode selection	6: PID terminal 1	
115	I4 input selection		11: Swash plate control enable (used when swash plate is controlled by overpressure mode during holding pressure).	7: PID terminal 2	
116	I5 input selection		12: Swash plate switching command	0: No function	
117	I6 input selection		13: PQ selection signal	0: No function	
118	I7 input selection		14: Following unit enable	0: No function	
119	I8 input selection		15-63: Reserved	0: No function	
21st screen					
120	S-RDY output	Output terminal function setup	0: No output	1: Servo ready	
121	ALM output selection		1: Servo ready 2: Alarm output	2: Alarm output	
122	COIN output selection		3: I2 terminal state 4: Swash plate control output	0: No function 4: Swash plate control output	
123	O1 output selection		5: Oil pressure reaches output	5: Oil pressure reaches output	
124	O2 output selection		6: Valve pressure discharge output 7-63: Reserved	5: Oil pressure reaches output	

Menu No.	Menu Name	Meaning	Parameter Range	Default Value	Unit
125	Overload protection mode	Current limit mode serves to limit the max output current based on the temperature of drive cooling fins; overload protection function does not work. It protection mode serves to determine whether threshold value is exceeded by judging the overload operation time, thus protecting IGBT	[0: Current limit mode, 1: It Protection mode 2 – 3: Reserved	0: Current limit mode	
22nd screen					
126	Bus overvoltage @	Bus voltage delay overvoltage protection voltage threshold	[0,800]	750	V
127	Bus overvoltage @ time	Bus voltage delay overvoltage protection detection time	[0,30000]	20	5ms
128	Bus overvoltage	Bus voltage transient overvoltage protection voltage threshold	[0,800]	780	V
129	Bus undervoltage @	Bus voltage delay undervoltage protection voltage threshold	[0,800]	380	V
130	Bus undervoltage @ time	Bus voltage delay overvoltage protection detection time	[0,30000]	150	5ms
131	Bus undervoltage	Bus voltage immediate undervoltage protection voltage threshold	[0,800]	320	V
23rd screen					
132	Bus undervoltage during enable	Voltage threshold value of bus voltage undervoltage protection when motor is enabled	[0,800]	315	V
133	AC overvoltage @	Voltage threshold of AC voltage delay overvoltage	[0,800]	487	V

Menu No.	Menu Name	Meaning	Parameter Range	Default Value	Unit
		protection			
134	AC overvoltage @ time	Detection time of AC voltage delay overvoltage protection	[0,30000]	40	5ms
135	AC overvoltage	Voltage threshold of AC voltage transient overvoltage protection	[0,800]	495	V
136	AC undervoltage @	Voltage threshold of AC voltage delay overvoltage protection	[0,800]	290	V
137	AC undervoltage @ time	Detection time of AC delay undervoltage protection	[0,30000]	100	5ms
24th screen					
138	AC undervoltage	Voltage threshold value of AC voltage transient overvoltage protection	[0,800]	0	V
139	Time of power-up overtime	Max delay time of soft start of relay closing	[0,30000]	2000	5ms
140	Motor protection temperature	Motor over-temperature protection value	[0,500]	125	°C
141	Module protection temperature	Module over-temperature protection value	[0,500]	86	°C
142	Air protection temperature	Over-temperature protection value of ambient temperature	[0,500]	400	°C
143	Overcurrent protection value	Software check overcurrent protection value	[0,900]	4R4→50 5R5→70 7R5→95 011→105 015→120 075→530	A
25th screen					
144	Overspeed protection time	FWD/REV overspeed protection delay time	[0,5000]	100	ms
145	FWD speed protection value	Set automatically during motor model selection	[0,6000]	2700	rpm
146	REV speed protection value	Set automatically during motor model selection	[-6000,0]	-2700	rpm

Menu No.	Menu Name	Meaning	Parameter Range	Default Value	Unit
147	Overpressure protection value	Upper limit of pressure feedback overpressure alarm	[0,250]	195	bar
148	Pressure sensor fault value	Min voltage threshold of 5V pressure sensor, 32767 corresponds to 5V	[0,32767]	0	
149	AC/DC error threshold	Calculate the rectification voltage via AC voltage, then compares it with the actual DC voltage, if their difference exceeds this parameter, rectification unit fault will be reported	[0,800]	80	V
26th screen					
150	Brake resistor heating factor	Automatically set to the brake resistor heating factor matched with the drive during motor model selection	[0,500]	4R4,5R5,7R 5,011,015→ 36 018,025,030 , 035,045,055 →40 075,095→0	
151	Brake resistor cooling factor	Automatically set to the brake resistor cooling factor matched with the drive during drive model selection	[0,500]	1	
152	Brake resistor overload threshold	Automatically set to the brake resistor cooling factor matched with the drive during drive model selection	[0,30000]	4R4,5R5,7R 5,011,015→ 429 018,025,030 ,035,045,05 5→292 075,095→37 4	
153	Motor short-circuit protection value	Motor 3PH grounding short-circuit, check current threshold value	[0,900]	10	A
154	Phase loss protection selection	Input voltage phase loss check during drive operation	0: Disable 1: Enable	1: Enable	

Menu No.	Menu Name	Meaning	Parameter Range	Default Value	Unit
155	Rectification overload protection selection	Current overload protection of rectification unit	0: Disable 1: Enable	0: Disable	
27th screen					
156	Brake resistor fault detection	Brake resistor fault protection function	0: Disable 1: Enable	1: Enable	
157	Resolver fault detection	Resolver fault protection function	0: Disable 1: Enable	1: Enable	

5.3.3 Commissioning Menu List

Menu No.	Menu Name	Meaning	Parameter Range	Default Value	Unit
1st screen					
0	Operation enable	Turn on/off motor drive function	Disable Enable	Related to the drive enable IO level	
1	Diagnosis enable	Turn on/off diagnosis function	Disable Enable	Disable	
2	Drive test (valid only after diagnosis enable is turned on)	Test the drive	Disable Enable	Disable	
3	Measure initial angle (valid only after diagnosis enable is turned on)	Refer to 9.2.5	Disable Enable	Disable	
4	Jogging enable (valid only after diagnosis enable is turned on)	Refer to 9.2.6	Disable Enable	Disable	
5	Motor parameter autotuning (valid only after diagnosis enable is turned on)	During motor autotuning, input motor nameplate parameter first, the precision of the motor parameter obtained via “static” mode depends on the accuracy of motor nameplate. When “dynamic” mode is used, no-load or light-load of	0: Disable 1: Dynamic 2: Static	0: Disable	

Menu No.	Menu Name	Meaning	Parameter Range	Default Value	Unit
		motor is required for obtaining accurate motor parameters			
2nd screen					
6	Control mode	Set the drive control mode	Speed mode Process mode	Process mode	
7	Speed reference (speed mode is valid)		The FWD/REV speed reference value cannot exceed the max motor speed	0	rpm
8	Process command mode	Used to select command input mode	Digital input, analog input, CAN continuous, 485 continuous, CANopen input, EtherCAT input, internal reference	Analog input	
9	Flow reference	Flow reference value is valid when command input mode is digital input	[0, max flow]	0	L/min
10	Pressure reference	Pressure reference value is valid when command input mode is digital mode	[0, max pressure]	0	bar
11	Max jogging speed	Max speed of the motor when forward and backward button is pressed	[0,1000]	100	rpm
3rd screen					
12	Resolver offset quantity	Resolver and motor zero position offset angle	[0, 4095]	0	
13	DA1	Set the output variable of analog output port 1	Pressure reference Pressure feedback Flow reference Flow feedback Speed reference Speed feedback Torque reference	Pressure feedback	

Menu No.	Menu Name	Meaning	Parameter Range	Default Value	Unit
			Torque feedback Resolver feedback DC voltage Phase current Fault word 1 Fault word 2 Communication command		
14	Max value of DA1	The corresponding digital input of max output of analog output port 1	[-32767,32767]	32767	
15	Min value of DA1	The corresponding digital input of min. output of analog output port 1	[-32767,32767]	0	
16	DA2	Set the output variable of analog output port 2	Pressure reference Pressure feedback Flow reference Flow feedback Speed reference Speed feedback Torque reference Torque feedback Resolver feedback DC voltage Phase current Fault word 1 Fault word 2 Communication command	Speed feedback	
17	Max value of DA2	Corresponding digital input of max output of analog output port 2	[-32767,32767]	16384	
4th screen					
18	Min value of DA2	Corresponding digital input of minimum output of	[-32767,32767]	-16384	

Menu No.	Menu Name	Meaning	Parameter Range	Default Value	Unit
		analog output port 2			
19	Output value of DA	Analog output port outputs this variable when DA variable output selects communication command	[-32767,32767]	0	
20	Clear fault manually	Void drive enable can clear the faults other than Err08, Err11, Err12, Err18 and Err24, while all the faults can be cleared via manual clearance	0: No action 1: Clear	0: No action	
21	Internal flow reference 0	Internal flow reference Dimension is flow full range	[0, 100.0]	0	%
22	Internal pressure reference 0	Internal pressure reference Dimension is pressure full range			
23	Internal flow reference 1	Internal flow reference Dimension is flow full range			
5th screen					
24	Internal pressure reference 1	Internal pressure reference Dimension is pressure full range	[0, 100.0]	0	%
25	Internal flow reference 2	Internal flow reference Dimension is flow full range			
26	Internal pressure reference 2	Internal pressure reference Dimension is pressure full range			
27	Internal flow reference 3	Internal flow reference Dimension is flow full range			
28	Internal pressure reference 3	Internal pressure reference Dimension is pressure full range			
29	Internal flow reference 4	Internal flow reference Dimension is flow full range			
6th screen					
30	Internal pressure reference 4	Internal pressure reference Dimension is pressure full range	[0, 100.0]	0	%

Menu No.	Menu Name	Meaning	Parameter Range	Default Value	Unit
31	Internal flow reference 5	Internal flow reference Dimension is flow full range			
32	Internal pressure reference 5	Internal pressure reference Dimension is pressure full range			
33	Internal flow reference 6	Internal flow reference Dimension is flow full range			
34	Internal pressure reference 6	Internal pressure reference Dimension is pressure full range			
35	Internal flow reference 7	Internal flow reference Dimension is flow full range			
7th screen					
36	Internal pressure reference 7	Internal pressure reference Dimension is pressure full range	[0, 100.0]	0	%

5.3.4 Multi-Pump Menu List

Menu No.	Menu Name	Instruction	Parameter Range	Default Value	Unit
1st screen					
0	Network enable/disable	Network enable control	Disable Enable	Disable	
1	Drive enable/disable on the network	Used to void the motor enable of all nodes, suitable for multi-pump mode only	Disable Enable	Related to the drive enable IO level	
2	Converging type	Select converging type	Single-pump Composite Multi-pump Multi-mode	Single-pump	
3	Node no.	If node no. is 0, it means master, if it is 1 – 15, it means slave	[0,15]	0	
4	Number of slave node	If node number is 0, slave node number means the number of slaves related to this master	[0,15]	0	
5	Node type	Set the working mode of	Independent unit	Independent	

Menu No.	Menu Name	Instruction	Parameter Range	Default Value	Unit
		the drive in the node	Control unit Following unit Flow loop unit	unit	
2nd screen					
6	Flow cut-in threshold	The condition for the next pump to engage, when the system flow exceeds the flow cut-in threshold of current pump, the next pump will engage in the operation	[0,100.0]	25	%
7	Upper limit of flow cut-in hysteresis	The condition for the next pump to engage, used to prevent the repeated start and stop of the pump when the flow is in threshold point	[0,100.0]	5	%
8	Lower limit of flow cut-in hysteresis	The condition for the next pump to engage, used to prevent the repeated start and stop of the pump when the flow is in threshold point	[0,100.0]	2.5	%
9	Multi-pump pressure proportional gain 0	The 0 th step of proportional parameter of multi-pump pressure PID control	[0,32767]	8000	
10	Multi-pump pressure integral gain 0	The 0 th step of integral parameter of multi-pump pressure PID control	[0,32767]	88	
11	Multi-pump pressure differential gain 0	The 0 th step of differential parameter of multi-pump pressure PID control	[0,32767]	0	
3rd screen					
12	Multi-pump pressure proportional gain 1	The 1 st step of proportional parameter of multi-pump pressure PID control	[0,32767]	8000	
13	Multi-pump pressure integral gain 1	The 1 st step of integral parameter of multi-pump	[0,32767]	88	

Menu No.	Menu Name	Instruction	Parameter Range	Default Value	Unit
		pressure PID control			
14	Multi-pump pressure differential gain 1	The 1 st step of differential parameter of multi-pump pressure PID control	[0,32767]	0	
15	Multi-pump pressure proportional gain 2	The 2 nd step of proportional parameter of multi-pump pressure PID control	[0,32767]	8000	
16	Multi-pump pressure integral gain 2	The 2 nd step of integral parameter of multi-pump pressure PID control	[0,32767]	88	
17	Multi-pump pressure differential gain 2	The 2 nd step of differential parameter of multi-pump pressure PID control	[0,32767]	0	
4th screen					
18	Multi-pump pressure proportional gain 3	The 3 rd step of proportional parameter of multi-pump pressure PID control	[0,32767]	8000	
19	Multi-pump pressure integral gain 3	The 3 rd step of integral parameter of multi-pump pressure PID control	[0,32767]	88	
20	Multi-pump pressure differential gain 3	The 3 rd step of differential parameter of multi-pump pressure PID control	[0,32767]	0	
21	ECAT synchronization mode	Set the synchronization mode between EtherCAT communication master and slave	0-Free, 1-SM2INT 2-Sync0	0	
22	ECAT synchronization time	Set the synchronous interruption cycle of DC Sync0 when EtherCAT communication uses DC mode	0-500us, 1-1ms 2-2ms 3-4ms	0	
23	485 local communication address	Set the local (slave) communication address during 485 serial communication	[1-255]	10	
5th screen					
24	485 communication	Select by parameters the	0:N,8,1	0	

Menu No.	Menu Name	Instruction	Parameter Range	Default Value	Unit
	check mode	check mode during 485 communication, support RTU mode only	1:E,8,1 2:O,8,1 3:N,8,2 4:E,8,2 5:O,8,2		
25	485 communication baud rate selection	The baud rate when selecting 485 communication by parameters	[9600,19200,38400,57600,115200]	9600	bps
26	CANOpen communication node number	Set the local (slave) communication node number during CAN communication	[1-127]	32	
27	CANOpen communication baud rate	The baud rate when selecting CAN communication by parameters	[1000,500,250,125,50,20]	500	kbps

5.3.5 Parameter Programming Menu List

Menu No.	Menu Name	Meaning
1st screen		
0	Parameter programming	Program internal RAM parameter of the drive to EEPROM
1	Restore default value	Used to restore the default parameters
2	Read parameters in batches	Read the parameters in EEPROM in DSP in batches
3	Program parameters in batches	Write parameters into the EEPROM in DSP in batches
4	Delete parameters in batches	Delete the parameters stored in EEPROM in HMI
5	Fault record check	Read fault record

- ※ When “restore default setup” is executed and “parameter programming” is not executed, if drive is powered off and re-powered on; the default parameter will not be restored.
- ※ After “programming parameters in batches” is executed, the drive needs to be powered off and re-powered on for the parameters written into EEPROM to be effective.

5.3.6 Shortcut Menu List

Menu No.	Menu Name	Meaning	Parameter Range	Default Value	Unit
1st screen					
0	Operation enable	Turn on/off motor drive function	Disable Enable	Related to the drive enable IO level	
1	Diagnosis enable	Turn on/off diagnosis function	Disable Enable	Disable	
2	Motor model selection	Motor model	Refer to 5.5.5 for details	U1013F. 17.3	
3	Pump model selection	Oil pump model	Refer to 5.5.5 for details	PUMP 100 mL/r	
4	Pressure feedback zero position calibration	The zero position offset of pressure sensor can be removed by pressure feedback zero position calibration	Pressure feedback zero position calibration		
5	Measure initial angle	Initial angle test can be done only when operation enable is voided	Disable Enable	Disable	
2nd screen					
6	Pressure full range	Set the pressure full range of the node This value will set both the pressure full range and max pressure value and meanwhile, adjust the pressure reference gain to make the pressure reference correspond to the newly set pressure full range value when pressure reference input is 9.9V	[1,250]	175	bar
7	Flow full range	Set the flow full range of the node This value will set both the flow full range and max flow value and meanwhile, adjust the flow reference gain to make the flow reference correspond to the newly set flow full range	[1,2400]	200	L/min

Menu No.	Menu Name	Meaning	Parameter Range	Default Value	Unit
		value when flow reference input is 9.9V			
8	Pressure zero position calibration	Calibrate when the upper PC outputs corresponding analog signal	Disable Enable	Disable	
9	Pressure full range calibration	Calibrate when the upper PC outputs corresponding analog signal	Disable Enable	Disable	
10	Flow zero position calibration	Calibrate when the upper PC outputs corresponding analog signal	Disable Enable	Disable	
11	Flow full range calibration	Calibrate when the upper PC outputs corresponding analog signal	Disable Enable	Disable	
3rd screen					
12	Parameter programming	Program the internal RAM parameter of the drive to EEPROM	Parameter programming	Parameter programming	
13	Jogging enable	Valid only if diagnosis enable is turned on, after the key enters jogging mode, press "forward" or "backward" key to make the motor rotate forward or backward.	Disable Enable	Disable	
14	Motor parameter autotuning (valid only if diagnosis enable is turned on)	During motor autotuning, input motor nameplate parameters first, the precision of the motor parameters obtained by "static" mode depends on the accuracy of motor nameplate parameter, when "dynamic" mode is used, no-load or light-load of motor is required to obtain accurate motor parameters	0: Disable 1: Dynamic 2: Static	Disable	
15	Pressure sensor model selection	Pressure sensor type	5v 10v 400bar	10v	

Menu No.	Menu Name	Meaning	Parameter Range	Default Value	Unit
16	Pressure proportional gain 0	The 0 th step of proportional parameter of pressure PID control	[0,32767]	13000	
17	Pressure integral gain 0	The 0 th step of integral parameter of pressure PID control	[0,32767]	100	
4th screen					
18	Pressure proportional gain 1	The 1 st step of proportional parameter of pressure PID control	[0,32767]	13000	
19	Pressure integral gain 1	The 1 st step of integral parameter of pressure PID control	[0,32767]	100	
20	Speed proportional gain 0	The 0 th step of proportional parameter of speed PI control	[0,32767]	7000	
21	Speed integral gain 0	The 0 th step of integral parameter of speed PI control	[0,32767]	140	
22	Speed proportional gain 1	The 1 st step of proportional parameter of speed PI control	[0,32767]	7000	
23	Speed integral gain 1	The 1 st step of integral parameter of speed PI control	[0,32767]	140	
5th screen					
24	Multi-step PID quick setup	Set whether to use multi-step mode for speed PI parameter and pressure PID parameter simultaneously	Disable Enable	Disable	
25	Speed proportion torque boost	Speed proportional gain parameter increases based on this parameter according to the ratio of feedback torque and max motor torque	[0,1000]	0	%
26	Speed integral torque boost	Speed integral gain parameter increases based on this parameter according to the ratio of feedback torque and max motor torque	[0,1000]	0	%

Menu No.	Menu Name	Meaning	Parameter Range	Default Value	Unit
27	Pump reverse rotation speed limit	Max reverse speed of oil pump	[0,-6000]	-300	rpm
28	Upper limit of reverse torque	Proportional coefficient of max motor reverse torque reduction	[0,100]	100	%
29	Over-pressure protection value	Upper limit of over-pressure alarm	[0,250]	195	bar
6th screen					
30	Pump stuck detection				

5.4 LED Display and Operation

5.4.1 LED Panel Instruction

Displayed Character	Corresponding Letter	Displayed Character	Corresponding Letter	Displayed Character	Corresponding Letter	Displayed Character	Corresponding Letter	Displayed Character	Corresponding Letter	Displayed Character	Corresponding Letter
0	0	1	1	2	2	3	3	4	4	5	5
6	6	7	7	8	8	9	9	A	A	b	b
C	C	d	d	E	E	F	F	G	G	H	H
I	I	J	J	K	K	L	L	M	M	N	N
O	O	P	P	q	q	R	R	S	S	T	T
U	U	V	V	W	W	X	X	Y	Y	Z	Z
.	.	-	-								

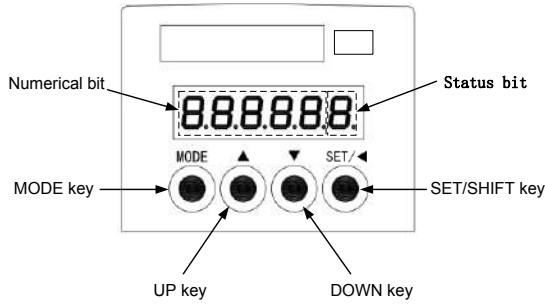

Button	Instruction	Button	Instruction
	Menu skip and cancel button		Upward button
	Long press (about 0.5s): set Short press: move leftward		Downward button

LED display reference table:

LED digital tube is lit up once servo drive is powered on. The first five characters display the value, and the last one indicates system state. LED value bit displays motor speed (rpm) by default (precision reaches to ones).

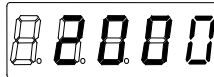

If fault occurred during power on or operation, the decimals points of LED state bit will flicker at 1s interval, and LED value bit will display fault code. The fault code is comprised of fault identifier (the first three bits from left to right of digital tube display Err) and fault code number (the last two bits from left to right of digital tube display two digits). After fault occurred, the fault code flickers at 1s interval.

If multiple faults occurred simultaneously, then multiple fault codes will display cyclically.

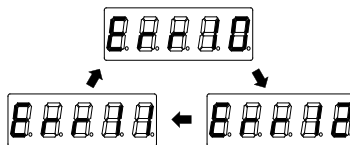

Keypad unlock:







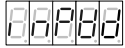

- A. In speed or fault display state, to operate on the keypad, users need to keep and keys pressed down for 1s, and the LED value bit will display ULOCK, which means the system keypad is unlocked and ready to be operated.

If the drive is in good condition, the drive keypad operation enters shortcut mode; if the drive is faulty, users need to press to enter shortcut mode.

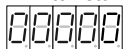
During keypad operation, if and are pressed together for 1s, LED value bit will display

LOCK which means the system keypad is locked, and LED value bit returns to speed or fault display state.

B. Users can also unlock the keypad in speed or fault display state by entering password. Press





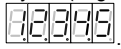

 key to enter password input prompt interface  (press  to return to the previous interface), and press  key to enter password input interface , (press  key to return to the previous interface), users can change the flickering bit by  key and change the value of the flickering bit via  or . After password is set, press  key and if the password is correct, it will enter shortcut mode, if not, enter password error interface  and after staying for a few seconds, enter password input interface. The initial password is 0.

When the negative number is less than 9999, the five-bit LED cannot display “-” (negative);

when the decimal points of 1, 2, 3 and 4 are lit up, it means negative number .

5.4.2 LED State Bit Instruction

The last bit of LED digital tube displays in real time the present running state of MH800 system, and its meaning is shown below:

No.	Displayed Content	Cycle	Control State
1		1s	Electronic
2		0s	Electricity
3		0s	Ready to run
4		1s	Run
5		1s	Fault
6		2s	Diagnosis
7		2s	Factory test

5.5 LED Panel Function

5.5.1 Keypad Operation Mode

This drive carries six kinds of keypad operation modes which can be switched via  key after keypad is unlocked.

Shortcut mode: used to display critical parameters

Quick setting mode: used to set critical setup parameters and motor commissioning

Monitor mode: used to display state parameter

Setting mode: used to set basic parameters

Commissioning mode: used for motor commissioning and parameter storage

Multi-pump mode: used to set multi-pump parallel parameters

The operation flowchart is shown below:

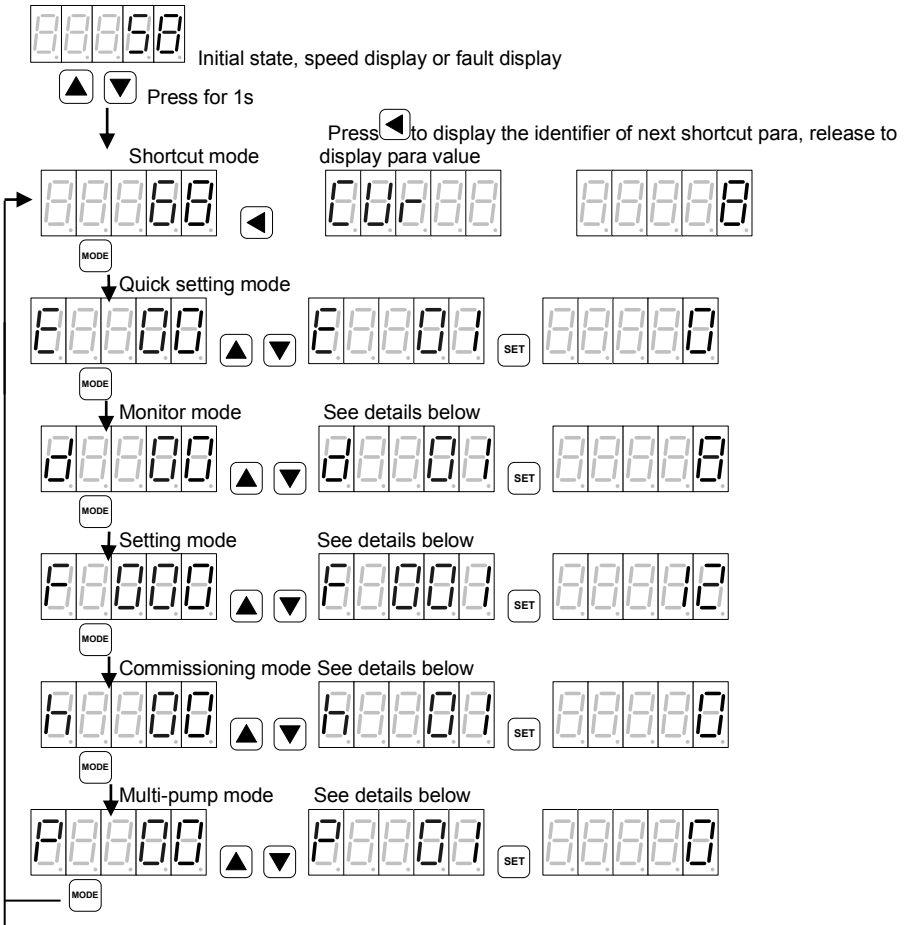

5.5.2 Short-cut Mode

Users can observe critical parameters of the drive under shortcut mode via pressing key. When and are pressed simultaneously for 1s in LOCK state, it will enter “shortcut mode” and LED displays the selected parameter value; press , LED displays the next parameter identifier to be displayed, release key, LED displays corresponding parameter value.













※ Under shortcut mode, if no button operation is performed within 4 minutes, it will switch to speed and fault display interface automatically.













Shortcut mode display parameter table:



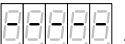
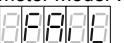
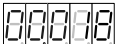



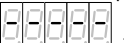
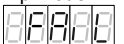



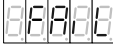



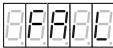

Identifier	Definition and Instruction	Parameter Range	Unit
SPD	Speed feedback	[-6000,6000]	rpm







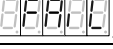





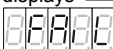



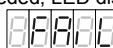



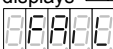
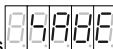

Identifier	Definition and Instruction	Parameter Range	Unit
CUR	Current feedback	[0,900.0]	A
RES	Resolver feedback	[0,4096]	
PRS	Pressure feedback	[-250,250]	bar
PIDS	PID step number	[0,3]	

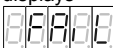





5.5.3 Quick Setting Mode

When pressing  key to select “quick setting mode”, LED value bit displays “E--xx”, in which xx represents different parameter identifiers. Press  or  key to select the parameter identifier to be set, and then press  key, LED value bit will display corresponding parameter value. When modifying parameter value, users can change the flickering bit via  key and modify the value of the flickering bit via  or . After modification, press  key to save the modified value and stop the flickering, then if  or   is pressed again, the bit which can be modified will flicker and the parameter value can be changed again. Press  key to exit.

Code	Definition and Instruction	Parameter Range	Default Value	Unit
E00	Operation enable Press  key to enter operation enable mode, LED displays operation enable state “ON” or “OFF”, press  to switch operation enable state.	OFF: Disable ON: Enable	Related to drive enable IO level	
E01	Motor model selection LED displays  , in which the first two bits are the selection number and the last two bits are the motor model code, press  or  key to select the motor to be set; press  key, LED displays  to set the motor. If setup is performed properly, newly selected motor model will be displayed, if failed, the LED displays  .	See motor model list below for details	U1013F. 17.3	
E02	Pump model selection LED displays  , in which the first two bits are selection number and the last three bits are oil pump displacement, press  or  key to select the oil pump to be set; press  key, LED displays  to set the oil pump. If setup is performed properly, the newly selected oil pump model will be displayed, if failed, the LED displays  .	See oil pump model list below for details	PUMP 100 mL/r	
E03	Pressure feedback zero position calibration LED displays pressure sensor analog voltage feedback value, press  to calibrate, if calibration is succeeded,			



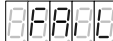

Code	Definition and Instruction	Parameter Range	Default Value	Unit
	LED displays  , if failed, LED displays  .			
E04	Measure initial angle Initial angle test can be done only when operation enable is OFF. Press  key to enter measure initial angle menu, and LED displays the previous resolver offset quantity, press  key to start measuring initial angle, and LED displays  , which means measuring is on. After measuring is succeeded, LED displays newly measured resolver offset quantity, if failed, LED displays  . During measuring, users can press MODE key to exit.			
E05	Pressure full range This value sets the pressure full range and max pressure value simultaneously, and meanwhile, adjusts the pressure reference gain to make the pressure reference correspond to the newly set pressure full range value when pressure reference is 9.9V. After entering, present pressure full range value will be displayed, press    keys to change to the desired value and press  key to confirm.	[1,250]	175	bar
E06	Flow full range This value sets the flow full range and max flow value simultaneously, and meanwhile, adjusts the flow reference gain to make the flow reference correspond to the newly set flow full range value when flow reference is 9.9V. After entering, present flow full range value will be displayed, press   keys to change to the desired value and press  key to confirm.	[1,2400]	200	L/min
E07	Pressure zero position calibration After pressing  key, LED displays pressure reference analog value, press SET key to perform pressure zero position calibration, and LED displays  . If calibration is succeeded, LED displays  , if failed, LED displays  .	Analog voltage range [0.00,9.99]		V
E08	Pressure full range calibration After pressing  key, LED displays present pressure reference analog value, confirm the value and press  key to perform pressure full range calibration, and LED	Analog voltage range [0.00,9.99]		V

Code	Definition and Instruction	Parameter Range	Default Value	Unit
	displays  . If calibration is succeeded, LED displays  . If failed, LED displays  .			
E09	Flow zero position calibration After pressing  key, LED displays flow reference analog value, press SET key to perform flow zero position calibration, and LED displays  . If calibration is succeeded, LED displays  . If failed, LED displays  .	Analog voltage range [0.00,9.99]		V
E10	Flow full range calibration After pressing  key, LED displays present flow reference analog value, confirm the value and press  key to perform flow full range calibration, and LED displays  . If calibration is succeeded, LED displays  . If failed, LED displays  .	Analog voltage range [0.00,9.99]		V
E11	Parameter programming After pressing SET key, LED displays  , press  key to start parameter programming, and LED displays  . If programming is succeeded, LED displays  . If failed, LED displays  .			
E12	Jogging After pressing  key to enter jogging mode, LED displays "JOG", then press  or  key to make the motor rotate forward or backward, press  key can exit from jogging mode and return to "Exx" menu.	 : Forward  : Reverse		
E13	Diagnosis enable Press  key to enter diagnosis enable mode, and LED displays diagnosis enable state "ON" or "OFF", press  to switch diagnosis enable state.	OFF: Disable ON: Enable	OFF	

Code	Definition and Instruction	Parameter Range	Default Value	Unit
E14	<p>Motor parameter autotuning Effective only if diagnosis enable activates motor parameter autotuning function.</p> <p>Press  key to enter motor parameter autotuning menu, and LED displays "0", select the parameter autotuning mode and press  key to start motor parameter autotuning. When LED displays , it means autotuning is on. If autotuning is succeeded, LED displays , if failed, LED displays . During autotuning, users can press  key to exit form autotuning, and LED displays .</p>	<p>0: Disable 1: Dynamic 2: Static</p>	0: Disable	
E15	Pressure sensor model selection	<p>5V: 1 – 5V sensor 10V: 0 – 10V sensor</p>	10V	
E16	Pressure proportional gain	[0,32767]	13000	
E17	Pressure integral gain	[0,32767]	100	
E18	Speed proportional gain	[0,32767]	7000	
E19	Speed integral gain	[0,32767]	170	
E20	Speed proportional torque boost	[0,1000]	0	%
E21	Speed integral torque boost	[0,1000]	0	%
E22	Max speed of pump reverse rotation	[0,-6000]	-300	Rpm
E23	Upper limit of reverse torque	[0,100]	100	%
E24	Over-pressure protection value	[0,500]	195	bar
E25	Pump stuck detection	<p>0: Disable 1: Enable</p>	1: Enable	

※ See [5.3.2](#), [5.3.3](#) and [5.3.5](#) for parameter instruction.

5.5.4 Monitoring MODE

When pressing  key to select "monitor mode", LED value bit displays "d--xx", in which xx is the identifier of the parameter. Press  or  key to select the parameter identifier to be displayed and press  after selection, then the LED panel will display corresponding parameter value, press  key to exit.

※ Under monitor mode, if there is no button operation within 4m, the system will switch to speed and fault display interface automatically.

The definition of the monitor parameters of the drive is shown below:

Code	Name	Parameter Range	Unit
d00	Flow reference	[0,2400.0]	L/min
d01	Pressure reference	[0,250.0]	bar
d02	System fault	System fault alarm (can display multiple faults which occurred simultaneously)	
d03	Motor current	[0,900.0]	A
d04	AC voltage	[0,500]	Vrms
d05	DC voltage	[0,800]	V
d06	Torque limit	[0,1800]	Nm
d07	Speed feedback	[-6000,6000]	Rpm
d08	Resolver feedback	[0,32767]	
d09	Pressure feedback	[-250,250]	bar
d10	Torque feedback	[-1800,1800]	Nm
d11	Running mode	3: Speed mode 4: Process mode	
d12	Motor temperature	[-52,244]	°C
d13	Drive temperature	[-46,244]	°C
d14	Ambient temperature	[-18,114]	°C
d15	Machine material	[0,999]	
d16	DSP software version		
d17	Panel software version		
d18	Max system pressure	[0,250.0]	bar
d19	Max system flow	[0,2400.0]	L/min
d20	Power	[0.00,327.67]	kW
d21	Converging type	0: Single pump; 1: Composite; 2: Multi-pump; 3: Multi-mode	
d22	Present PID step	[0,3]	
d23	Flow reference voltage	[0,10.00]	V
d24	Pressure reference voltage	[0,10.00]	V
d25	Pressure feedback voltage	[0,10.00]	V
d26	Output voltage	[-1000,1000]	V

Code	Name	Parameter Range	Unit
d27	Digital IO	<p>If input port indicator lights up, it means low level (if S_ON input port lights up, it means high level); if output port indicator lights up, it means cut-off</p>	
d28	Motor configuration table version		

※ See 5.3.1 for parameter instructions.

5.5.5 Setting Mode

When pressing **MODE** key to select “setting mode”, LED value bit displays “F--xx”, in which xx is the parameter identifier. Press **▲** or **▼** key to select the parameter identifier to be set and press **SET** key after selection, then LED panel will display corresponding parameter value. Press **◀** or **▶** key the bit which can be modified will flicker. When modifying parameter values, users can change the flickering bit by **◀** key and modify the value of the flickering bit via **▲** or **▼**. After modification, press **SET** key to save the modified parameter and stop the flickering, then press **◀** or **▶** again to re-modify the parameter value and the bit can be modified will flicker. Press **MODE** key to exit.

The selection of drive, motor and oil pump differ with other parameter selections, see details below:
Parameter setup operation flowchart:

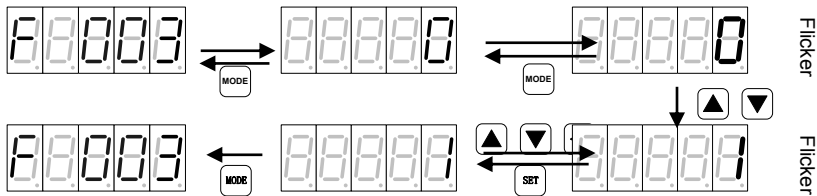

※ For calibration command eg pressure linear zero position calibration, if LED displays 0 after setup, it means calibration is succeeded; if LED keeps displaying 1, it means calibration is failed.

Drive setup operation flowchart:

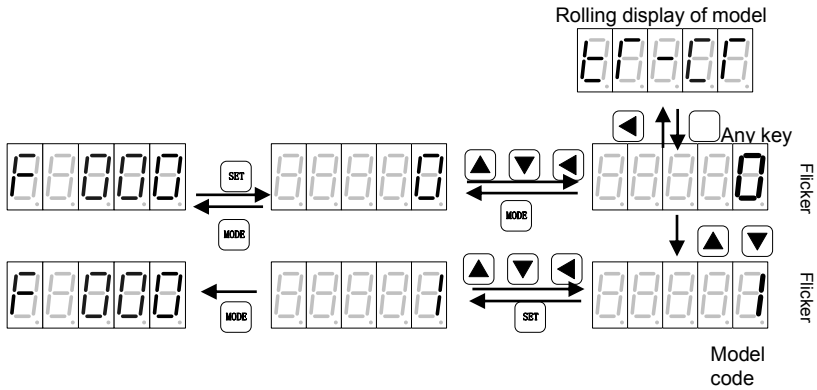

Motor setup operation flowchart:

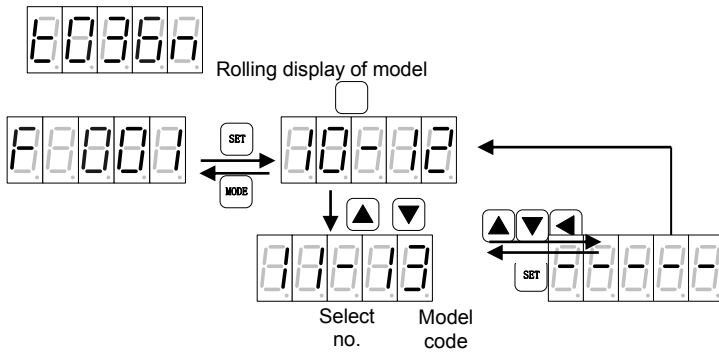

Select no.: the serial number for each motor model.

Model code: the code of each motor model

Oil pump setup operation flowchart:

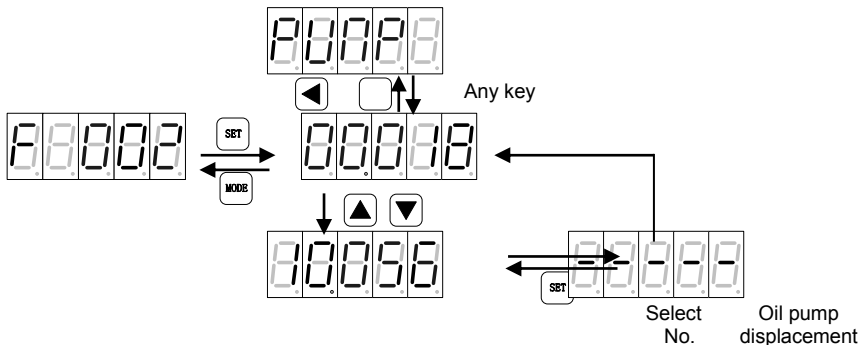

Select no.: the serial number of each oil pump model.

- ※ Under setting mode, if there is no button operation within 4m, the system will switch to speed and fault display interface automatically.

1) Drive model list

Drive Selection Order	LED Display Mode	Drive Model	Drive Model Code
2	4r4-0	SV-MH800-4R4-33-S	42
3	5r5-0	SV-MH800-5R5-33-S	43
4	7r5-0	SV-MH800-7R5-33-S	44
5	011-0	SV-MH800-011-33-S	45
6	015-0	SV-MH800-015-33-S	46
7	018-0	SV-MH800-018-33-S	47
8	025-0	SV-MH800-025-33-S	48
9	030-0	SV-MH800-030-33-S	49
10	035-0	SV-MH800-035-33-S	50
11	045-0	SV-MH800-045-33-S	51
12	055-0	SV-MH800-055-33-S	52
13	075-0	SV-MH800-075-33-S	53

2) Motor model list:

Motor Selection No.	Motor Model	Motor Model Code	Brand	Winding Temperature Resistor Model
0	K038F18C18P	60	KINWAY	Pt1000
1	K036F20C18P	65	KINWAY	Pt1000
2	K058F18C18P	33	KINWAY	Pt1000
3	K060F18C18P	66	KINWAY	Pt1000
4	K072F18C18P	61	KINWAY	Pt1000
5	K091F15C18P	34	KINWAY	Pt1000
6	K111F15C18P	35	KINWAY	Pt1000
7	K132F18C18P	62	KINWAY	Pt1000
8	K187F18C25P	63	KINWAY	Pt1000
9	K208F15C25P	98	KINWAY	Pt1000
10	K070F20D18P	68	KINWAY	Pt1000
11	K087F20D18P	64	KINWAY	Pt1000
12	K105F20D18P	69	KINWAY	Pt1000
13	K189F15D25P	70	KINWAY	Pt1000
14	K172F18D25P	71	KINWAY	Pt1000
15	K260F20D25P	72	KINWAY	Pt1000
16	K053F20E18P	47	ANXIN	KTY84
17	K070F20E18P	48	ANXIN	KTY84

Motor Selection No.	Motor Model	Motor Model Code	Brand	Winding Temperature Resistor Model
18	K087F20E18P	49	ANXIN	KTY84
19	K105F20E18P	50	ANXIN	KTY84
20	K189F15E25P	51	ANXIN	KTY84
21	K172F18E25P	52	ANXIN	KTY84
22	K260F20E25P	53	ANXIN	KTY84
23	U1004F.15.3	12	PHASE	KTY84
24	U1004F.17.3	13	PHASE	KTY84
25	U1004F.20.3	14	PHASE	KTY84
26	U1005F.15.3	15	PHASE	KTY84
27	U1005F.17.3	16	PHASE	KTY84
28	U1005F.20.3	17	PHASE	KTY84
29	U1007F.15.3	18	PHASE	KTY84
30	U1007F.17.3	9	PHASE	KTY84
31	U1007F.20.3	19	PHASE	KTY84
32	U1008F.15.3	20	PHASE	KTY84
33	U1008F.17.3	21	PHASE	KTY84
34	U1008F.20.3	22	PHASE	KTY84
35	U1010F.15.3	6	PHASE	KTY84
36	U1010F.18.3	10	PHASE	KTY84
37	U1010F.20.3	4	PHASE	KTY84
38	U1013F.15.3	23	PHASE	KTY84
39	U1013F.17.3	24	PHASE	KTY84
40	U1013F.18.3	25	PHASE	KTY84
41	U1013F.20.3	8	PHASE	KTY84
42	U1320F.15.3	26	PHASE	KTY84
43	U1320F.17.3	11	PHASE	KTY84
44	U1320F.18.3	27	PHASE	KTY84
45	U1320F.20.3	28	PHASE	KTY84
46	U1330F.15.3	36	PHASE	KTY84
47	U1330F.18.3	37	PHASE	KTY84
48	U1330F.20.3	38	PHASE	KTY84
49	S18-357	41	SHENDA	KTY84
50	S18-480	42	SHENDA	KTY84
51	S18-5103	43	SHENDA	KTY84
52	S18-6128	44	SHENDA	KTY84
53	S18-8186	45	SHENDA	KTY84
54	S25-4230	40	SHENDA	KTY84

Motor Selection No.	Motor Model	Motor Model Code	Brand	Winding Temperature Resistor Model
55	K130F22C18P	90	KINWAY	KTY84
56	K135F25C25P	91	KINWAY	KTY84
57	K341F18C25P	30	KINWAY	Pt1000
58	K105F20C18P	31	KINWAY	Pt1000
59	K122F23C25P	92	KINWAY	Pt1000
60	K148F21C25P	93	KINWAY	Pt1000
61	K148F23C25P	94	KINWAY	Pt1000
62	K194F23C25P	95	KINWAY	Pt1000
63	K224F23C25P	96	KINWAY	Pt1000
64	K240F22C25P	97	KINWAY	Pt1000
65	K290F18C25P	99	KINWAY	Pt1000
66	K395F15C25P	100	KINWAY	Pt1000
67	MM18-5R5B47	101	KINWAY	Pt1000
68	MM18-4R4B47	102	KINWAY	Pt1000
69	K156F20E25P	58	ANXIN	KTY84
70	K235F20C25P	78	KINWAY	Pt1000
71	U1315F.15.3	59	PHASE	KTY84
72	K078F20C18P	79	KINWAY	Pt1000
73	K239F18C25P	83	KINWAY	Pt1000

Note: If the motor selected is not listed in above table, users can obtain relevant motor parameters by motor parameter autotuning. See [6. Motor parameter autotuning](#) for details.

3) Oil pump model list:

Oil Pump Selection No.	Oil Pump Model	Oil Pump Displacement mL/r	Default Max Flow
0	PUMP 018 mL/r	18	40 L/min
1	PUMP 025 mL/r	25	55 L/min
2	PUMP 028 mL/r	28	62 L/min
3	PUMP 031 mL/r	31	68 L/min
4	PUMP 032 mL/r	32	70 L/min
5	PUMP 036 mL/r	36	79 L/min
6	PUMP 037 mL/r	37	81 L/min
7	PUMP 040 mL/r	40	88 L/min
8	PUMP 045 mL/r	45	99 L/min
9	PUMP 050 mL/r	50	110 L/min
10	PUMP 056 mL/r	56	123 L/min
11	PUMP 062 mL/r	62	136 L/min

Oil Pump Selection No.	Oil Pump Model	Oil Pump Displacement mL/r	Default Max Flow
12	PUMP 063 mL/r	63	139 L/min
13	PUMP 064 mL/r	64	141 L/min
14	PUMP 071 mL/r	71	142 L/min
15	PUMP 075 mL/r	75	150 L/min
16	PUMP 078 mL/r	78	156 L/min
17	PUMP 080 mL/r	80	160 L/min
18	PUMP 090 mL/r	90	180 L/min
19	PUMP 100 mL/r	100	200 L/min
20	PUMP 101 mL/r	101	202 L/min
21	PUMP 120 mL/r	120	240 L/min
22	PUMP 125 mL/r	125	250 L/min
23	PUMP 130 mL/r	130	260 L/min
24	PUMP 140 mL/r	140	280 L/min
25	PUMP 150 mL/r	150	300 L/min
26	PUMP 160 mL/r	160	320 L/min

Parameter table definition of setting mode is shown below:





Code	Definition and Instruction	Parameter Range	Default Value	Unit
F000	Drive model selection	See drive model list above for details	The same with drive label	
F001	Motor model selection	See motor model list above for details	U1013F.17.3	
F002	Pump model selection	See oil pump model list above for details	PUMP 100 mL/r	
F003	Pressure feedback zero position calibration	0: No calibration 1: Calibration	0	
F004	Pressure calibration mode	0: Linear pressure calibration 1: Polyline pressure calibration	0	
F005	Flow calibration mode	0: Linear flow calibration 1: Polyline flow calibration	0	
F006	Pressure calibration	0: No action 1: Linear zero position 2: Linear range 3: Polyline point 0 4: Polyline point 1 5: Polyline point 2	0	During linear zero position or range calibration, if LED displays 0, it means







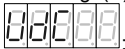
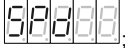
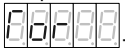
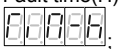

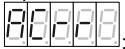
Code	Definition and Instruction	Parameter Range	Default Value	Unit
		6: Polyline point 3 7: Polyline point 4 8: Polyline point 5 9: Polyline point 6 10: Polyline point 7 11: Polyline point 8 12: Polyline point 9 13: Polyline point 10 14: Polyline point 11 15: Polyline point 12		calibration is succeeded, otherwise, it is failed. For polyline calibration, if LED displays the original value after setup, it means calibration is succeeded, otherwise, it is failed
F007	Flow calibration	0: No action 1: Linear zero position 2: Linear range 3: Polyline point 0 4: Polyline point 1 5: Polyline point 2 6: Polyline point 3 7: Polyline point 4 8: Polyline point 5 9: Polyline point 6 10: Polyline point 7 11: Polyline point 8 12: Polyline point 9 13: Polyline point 10 14: Polyline point 11 15: Polyline point 12	0	During linear zero position or range calibration, if the LED displays 0, it means calibration is succeeded, otherwise, it is failed. After polyline calibration, if LED displays the original value, it means calibration is succeeded, otherwise, it is failed.
F008	Pressure filter	[1,32]	6	Moving average sampling times(1ms)
F009	Flow filter	[1,32]	6	Moving average

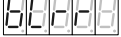
Code	Definition and Instruction	Parameter Range	Default Value	Unit
				sampling times(1ms)
F010	Pressure full range This value will set pressure full range and max pressure value simultaneously, and meanwhile, adjust the pressure reference gain to make the pressure reference correspond to the newly set pressure full range value when pressure reference input is 9.99V	[1,250]	175	bar
F011	Flow full range This value will set flow full range and max flow value simultaneously and meanwhile, adjust the flow reference gain to make the flow reference correspond to the newly set flow full range value when flow reference input is 9.99V	[1,2400]	200	L/min
F012	Max pressure	[0,250]	180	bar
F013	Max flow	[0,2400]	220	L/min
F014	Speed proportional gain	[0,32767]	7000	
F015	Speed integral gain	[0,32767]	170	
F016	Pressure feedback gain	[0,32767]	8182	
F017	Pressure reference rising slope	[0,32767]	16000	
F018	Pressure reference declining slope	[0,32767]	16000	
F019	Pressure proportional gain 0	[0,32767]	13000	
F020	Pressure integral gain 0	[0,32767]	100	
F021	Pressure differential gain 0	[0,32767]	0	
F022	Pressure proportional gain 1	[0,32767]	13000	
F023	Pressure integral gain 1	[0,32767]	100	
F024	Pressure differential gain 1	[0,32767]	0	
F025	Pressure proportional gain 2	[0,32767]	13000	

Code	Definition and Instruction	Parameter Range	Default Value	Unit
F026	Pressure integral gain 2	[0,32767]	100	
F027	Pressure differential gain 2	[0,32767]	0	
F028	Pressure proportional gain 3	[0,32767]	13000	
F029	Pressure integral gain 3	[0,32767]	100	
F030	Pressure differential gain 3	[0,32767]	0	
F031	Pump displacement	[0,32767]	100	mL/r
F032	Pump leakage	[0,1.00]	0	L/min/bar
F033	Max pump reverse speed	[0,-6000]	-300	rpm
F034	Max motor speed	[0,6000]	2200	rpm
F035	DC voltage calibration	[0,800](fine tuning only)	DC voltage when entering the menu	V
F036	AC voltage calibration	[0,800](fine tuning only)	AC voltage when entering the menu	V
F037	Base flow enable	0: no base flow 1: with base flow	0	
F038	Base flow pressure	[0,250.0]	3	bar
F039	Flow of base flow	[0,327.67]	0.95	L/Min
F040	Overshoot limit value	[5,50]	30	bar
F041	Motor rotation direction	0: Forward 1: Reverse	0	
F042	Resolver direction	0: Forward 1: Reverse	0	
F043	Backpressure mode	0: Manual 1: Automatic	0	
F044	Pressure sensor model selection	5V 10V 400bar	10V	
F045	Plunger pump model selection	0: Single displacement 1: Dual displacement	0	
F046	Plunger pump displacement ratio	[0,100.0]	20	%
F047	Wobble plate switching pressure threshold	[0,250.0]	195	bar
F048	Displacement pressure judging delay	[0,32767]	100	ms
F049	DA1	0: Pressure reference	1	

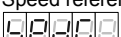
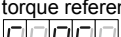
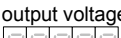
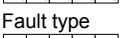
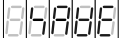
Code	Definition and Instruction	Parameter Range	Default Value	Unit
		1: Pressure feedback 2: Flow reference 3: Flow feedback 4: Speed reference 5: Speed feedback 6: Torque reference 7: Torque feedback 8: Resolver feedback 9: DC voltage 10: Phase current 11: Fault word 1 12: Fault word 2 13: Communication command		
F050	DA1 max value	[-32767,32767]	32767	
F051	DA1 min value	[-32767,32767]	0	
F052	DA2	0: Pressure reference 1: Pressure feedback 2: Flow reference 3: Flow feedback 4: Speed reference 5: Speed feedback 6: Torque reference 7: Torque feedback 8: Resolver feedback 9: DC voltage 10: Phase current 11: Fault word 1 12: Fault word 2 13: Communication command	5	
F053	DA2 max value	[-32767,32767]	16384	
F054	DA2 min value	[-32767,32767]	-16384	
F055	DA output value	[-32767, 32767]	0	
F056	Wobble plate switching rising delay	[0, 32767]	10	ms
F057	Wobble plate switching declining delay	[0, 32767]	10	ms
F058	Upper limit of speed switching	[0, 6000]	1200	rpm
F059	Lower limit of speed switching	[0, 6000]	200	rpm

Code	Definition and Instruction	Parameter Range	Default Value	Unit
F060	Flow reference zero position deadzone	[0.00, 100.00]	0.5	%
F061	Pressure reference zero position deadzone	[0.00, 100.00]	0.5	%
F062	Pressure feedback zero position deadzone	[0.00, 100.00]	0	%
F063	OUT2 connection pressure coefficient	[0.00, 100.00]	90	%
F064	Negative torque suppression control	0: Disable 1: Enable	0	
F065	Displacement switching mode	0: Overpressure 1: Overpressure during holding pressure	0	
F066	Restore default parameters	0: Disable 1: Restore	0	
F067	Check fault record (display fault code)	1: Fault 1 2: Fault 2 3: Fault 3 4: Fault 4 5: Fault 5 After entering, it displays the last fault occurred (no. is 1). Press  key to display the last but one fault (no. is 2), press  to display in order the following information when fault occurred: DC voltage(V)  ; Speed feedback(rpm)  ; Torque feedback(Nm)  ; Fault time(H)  ; Fault time(m)  ; A phase current (Apk)  ;		

Code	Definition and Instruction	Parameter Range	Default Value	Unit
		B phase current (A)pk  Motor current(A)  Drive temperature (°C)  Motor temperature (°C)  Speed reference (rpm)  torque reference (Nm)  output voltage (V)  Fault type 		
F068	Parameter programming	Parameter programming After pressing SET key, LED displays  , press  key to start parameter programming, LED displays  If programming is succeeded, LED displays  , if failed, LED displays 		
F069	Keypad unlock password	[0,99999]	00000	
F070	Rated motor voltage	[0,800]	334	V
F071	Rated motor current	[0,900]	64	A
F072	Rated motor speed	[0,6000]	1467	rpm
F073	Rated motor frequency	[0,600]	97.8	Hz
F074	Motor counter-emf	[0.0,800.0]	183.1	V/Krpm

Code	Definition and Instruction	Parameter Range	Default Value	Unit
F075	Motor temperature sensor	0: NTC 1: PTC 2: KTY84 3: PT1000	2	
F076	Reserved			
F077	Reserved			
F078	Reserved			
F079	Pressure sensor range	[0,250.0]	250	bar
F080	Pressure feedback fine-tuning coefficient	[50,200]	100	%
F081	Min value of flow reference	[0,2400.0]	0	L/min
F082	Over-modulation enable	[0,1]	0	1: Enable
F083	Over-modulation ratio	[100,115]	105	%
F084	Carrier frequency	[4k,5k,8k,10k,3k,2k]	3k	Hz
F085	Overload protection mode	[0: Current limit mode, 1: It protection mode, 2, 3: Reserved]	0	
F086	Bus overvoltage protection@	[0,1000]	750	V
F087	Bus overvoltage protection @ time	[0,30000]	20	5ms
F088	Bus overvoltage protection	[0,1000]	780	V
F089	Bus undervoltage protection@	[0,1000]	380	V
F090	Bus undervoltage protection @ time	[0,30000]	150	5ms
F091	Bus undervoltage protection	[0,1000]	320	V
F092	Bus undervoltage protection during enable	[0,1000]	315	V
F093	AC overvoltage protection@	[0,1000]	487	V
F094	AC overvoltage protection @ time	[0,30000]	40	5ms
F095	AC overvoltage	[0,1000]	495	V
F096	AC undervoltage protection@	[0,1000]	290	V
F097	AC undervoltage protection @ time	[0,30000]	100	5ms
F098	AC undervoltage	[0,1000]	0	V
F099	Time of power-on overtime	[0,30000]	2000	5ms
F100	Motor protection temperature	[0,500]	125	°C
F101	Module protection temperature	[0,500]	86	°C

Code	Definition and Instruction	Parameter Range	Default Value	Unit
F102	Air protection temperature	[0,500]	400	°C
F103	Overcurrent protection value	[0,900]	4R4→50 5R5→70 7R5→95 011→105 015→120 018→180 025→220 030→260 037→360 045→440 055→480 075→530	A
F104	Forward speed protection value	[0,6000]	2700	rpm
F105	Reverse speed protection value	[-6000,0]	-2700	rpm
F106	Overpressure protection value	[0,250]	195	bar
F107	Pressure sensor fault value	[0,32767]	0	
F108	ACDC sampling error voltage	[0,800]	80	V
F109	Brake resistor heating factor	[0,500]	4R4→35 5R5→35 7R5→35 011→35 015→69 018→69 025→69 030→40 037→40 045→40 055→40 075→0	
F110	Brake resistor cooling factor	[0,500]	1	
F111	Brake resistor overload threshold	[0,30000]	4R4→374 5R5→374 7R5→374 011→374 015→374 018→374 025→374	

Code	Definition and Instruction	Parameter Range	Default Value	Unit
			030→292 037→292 045→292 055→292 075→374	
F112	Motor short-circuit protection value	[0,900]	10	A
F113	Phase loss protection selection	0: Disable 1: Enable	1	
F114	Rectification overload protection selection	0: Disable 1: Enable	Disable	
F115	Speed feedback filter mode	0: Moving average;1: Least squares; Effective only after re-power on	0	
F116	Speed proportional gain1	[0,32767]	7000	
F117	Speed integral gain 1	[0,32767]	170	
F118	Speed gain switching speed 0	[0,6000]	5994	rpm
F119	Speed gain switching speed 1	[0,6000]	5994	rpm
F120	Speed control rigidity	[1,14]	9	
F121	Motor inertia	[0,0.655]	0.018	Kgm2
F122	Motor torque coefficient	[0,100.00]	2.6	Nm/Arms
F123	Motor autotuning direction	0: Forward;1: Reverse	0	
F124	Rated drive power	[0.00,327.67]	4R4→4.40 5R5→5.50 7R5→7.50 011→11.00 015→15.00 018→18.00 025→25.00 030→30.00 037→37.00 045→45.00 055→55.00 075→75.00	kW
F125	Rated drive current	[0,900]	4R4→18.4 5R5→25.5 7R5→31.1 011→36.8 015→42.4	A













Code	Definition and Instruction	Parameter Range	Default Value	Unit
			018→53.8 025→70.7 030→90.5 037→113.1 045→140.0 055→173.9 075→220.6	
F126	Torque limit	[0,1800]	425	Nm
F127	Disturbance compensation gain	[0,200]	0	%
F128	Disturbance compensation filter frequency	[0,5000]	500	Hz
F129	Disturbance compensation lag cycle	[0,15]	5	Cycle (speed loop cycle)
F130	Overspeed protection time	[0,5000]	100	ms
F131	Flow reference rising slope	[0,32767]	16000	
F132	Flow reference declining slope	[0,32767]	16000	
F133	Brake resistor fault detection	0: Disable 1: Enable	1	
F134	PWM voltage compensation	0: Disable 1: Enable	0	
F135	Pump stuck detection	0: Disable 1: Enable	1	
F136	Oil circuit pressure discharge mode	0: Normal oil circuit 1: Valve pressure discharge oil circuit	0	
F137	Upper limit of reverse torque	[0,100]	100	%
F138	Speed integral torque boost	[0,1000]	0	%
F139	Speed multi-step PI enable	0: Disable 1: Enable	0	
F140	Pressure multi-step PI enable	0: Disable 1: Enable	0	
F141	Speed multi-step proportion 1	[0,32767]	7000	
F142	Speed multi-step integral 1	[0,32767]	140	
F143	Speed multi-step proportion 2	[0,32767]	7000	

Code	Definition and Instruction	Parameter Range	Default Value	Unit
F144	Speed multi-step integral 2	[0,32767]	140	
F145	Speed multi-step proportion 3	[0,32767]	7000	
F146	Speed multi-step integral 3	[0,32767]	140	
F147	Starting speed of valve pressure discharge	[-300,300]	0.9	rpm
F148	Starting pressure of valve pressure discharge	[0,250]	20	bar
F149	Closing pressure of valve pressure discharge	[0,250]	0.5	bar
F150	Cut-in speed of pressure-hold feedforward	[-6000,6000]	100	Rpm
F151	Cut-in pressure of pressure-hold feedforward	[0,250]	0.8	bar
F152	Pressure-hold gain	[0,32767]	0	
F153	Pressure full range voltage	[0,1100]	1000	0.01V
F154	Flow full range voltage	[0,1100]	1000	0.01V
F155	Resolver fault detection	0: Disable 1: Enable	1	
F156	PID terminal usage mode	0: Commonly used 1: Specific for casting machine	0	
F157	ALM_RST input selection	0: No function 1: Fault reset	1	
F158	S_ON input selection	2: Drive enable	2	
F159	I1 input selection	3: Shunt/converging selection	3	
F160	I2 input selection	4: Storing signal input	4	
F161	I3 input selection	5: Motor rotation direction	6	
F162	I4 input selection	6: PID terminal 1	7	
F163	Reserved	7: PID terminal 2	0	
F164	Reserved	8: PID terminal 3	0	
F165	Reserved	9: PID terminal 4	0	
F166	Reserved	10: Trigger mode selection 11: Swash plate control enable(used when	0	

Code	Definition and Instruction	Parameter Range	Default Value	Unit
		swash plate is controlled by overpressure mode during holding pressure) 12: Swash plate switching command 13: Pressure flow control selection signal 14: Following unit enable 15 – 63: Reserved		
F167	S_RDY output selection	0: No function	1	
F168	ALM output selection	1: Servo ready 2: Alarm output	2	
F169	Reserved	3: I2 terminal state	0	
F170	O1 output selection	4: Swash plate control output	4	
F171	O2 output selection	5: Oil pressure reaches output 6: Valve pressure discharge output 7 – 63: Reserved	5	

※ See [5.3.2](#) and [5.3.5](#) for parameter instructions.





5.5.6 Commissioning Mode

When pressing  key to select “commissioning mode”, LED panel will display “h--xx”, in which xx is parameter identifier. Press  or  to select the parameter identifier to be set, after selection, press  key, and LED panel will display corresponding parameter value. When modifying parameter values, users can change the flickering bit by , and modify the value of the flickering bit via  or  key. After modification, press  key to save the modified value and stop the flickering, then press  or   key again to re-modify the parameter value, and the bit can be modified will flicker. Press  key to exit.

※ Under commissioning mode, if there is no button operation within 4m, the system will switch to speed and fault display interface automatically.

Parameter table definition of setup mode is shown below:













Code	Definition and Instruction	Parameter Range	Default Value	Unit
H00	Operation enable	0: Disable 1: Enable	Related to the drive enable IO level	

Code	Definition and Instruction	Parameter Range	Default Value	Unit
H01	Diagnosis enable	0: Disable 1: Enable	0	
H02	Diagnosis content (effective only when diagnosis enable is turned on)	0: No action 1: Measure initial angle 2: Jogging enable 3 – 5: Invalid 6: Drive test	0	
H03	Jogging (effective only when diagnosis enable is turned on)	 : Forward  : Reverse		
H04	Control mode	3: Speed mode 4: Process mode	4	
H05	Speed reference (control mode is: speed mode valid)	Related to motor model	0	rpm
H06	Process command mode	Digital input, Analog input, CAN continuous, 485 continuous, CANopen input, EtherCAT input, Internal reference	1	
H07	Flow reference (process command mode is communication input)	[0, max flow]	0	l/m
H08	Pressure reference (process command mode is communication input)	[0, max pressure]	0	kg
H09	Max jogging speed	The max motor speed when  and  keys are pressed, [0,100]		rpm
H10	Resolver offset quantity	[0,4095]	0	
H11	Motor parameter autotuning (effective only when diagnosis enable is turned on)	0: Disable 1: Dynamic 2: Static	0	
H12	Advanced parameter operation enable	11111: Disable 99999: Enable Other value: No action	00000	
H13	Fault clear	0: No action 1: Clear	0	
H14	Internal flow reference 0	[0, 100.0]	0	%
H15	Internal flow reference 1	[0, 100.0]	0	%
H16	Internal flow reference 2	[0, 100.0]	0	%

Code	Definition and Instruction	Parameter Range	Default Value	Unit
H17	Internal flow reference 3	[0, 100.0]	0	%
H18	Internal flow reference 4	[0, 100.0]	0	%
H19	Internal flow reference 5	[0, 100.0]	0	%
H20	Internal flow reference 6	[0, 100.0]	0	%
H21	Internal flow reference 7	[0, 100.0]	0	%
H22	Internal pressure reference 0	[0, 100.0]	0	%
H23	Internal pressure reference 1	[0, 100.0]	0	%
H24	Internal pressure reference 2	[0, 100.0]	0	%
H25	Internal pressure reference 3	[0, 100.0]	0	%
H26	Internal pressure reference 4	[0, 100.0]	0	%
H27	Internal pressure reference 5	[0, 100.0]	0	%
H28	Internal pressure reference 6	[0, 100.0]	0	%
H29	Internal pressure reference 7	[0, 100.0]	0	%

※ See [5.3.3](#) for parameter instructions

5.5.7 Multi-pump Mode

When pressing  key to select “multi-pump mode”, LED panel will display “p--xx”, in which xx is parameter identifier. Press  or  to select the parameter identifier to be set, after selection, press  key, and LED panel will display corresponding parameter value. When modifying parameter values, users can change the flickering bit by , and modify the value of the flickering bit via  or  key. After modification, press  key to save the modified value and stop the flickering, then press  or   key again to re-modify the parameter value, and the bit can be modified will flicker. Press  key to exit.

Code	Definition and Instruction	Parameter Range	Default Value	Unit
P00	Network enable	0: Disable 1: Enable	0	
P01	Drive enable on the network	0: Disable 1: Enable	Related to drive enable IO level	
P02	Converging type	0: Single pump 1: Composite 2: Multi-pump 3: Multi-mode	0	
P03	Node number	[0,15]	0	
P04	Slave node number	[0,15]	0	
P05	Node type	0: Independent unit	0	

Code	Definition and Instruction	Parameter Range	Default Value	Unit
		1: Control unit 2: Following unit 3: Flow loop unit		
P06	Flow cut-in threshold	[0,100.0]	25	%
P07	Upper limit of flow cut-in hysteresis	[0,100.0]	5	%
P08	Lower limit of flow cut-in hysteresis	[0,100.0]	2.5	%
P09	Multi-pump pressure proportional gain 0	[0,32767]	8000	
P10	Multi-pump pressure integral gain 0	[0,32767]	88	
P11	Multi-pump pressure differential gain 0	[0,32767]	0	
P12	Multi-pump pressure proportional gain 1	[0,32767]	8000	
P13	Multi-pump pressure integral gain 1	[0,32767]	88	
P14	Multi-pump pressure differential gain 1	[0,32767]	0	
P15	Multi-pump pressure proportional gain 2	[0,32767]	8000	
P16	Multi-pump pressure integral gain 2	[0,32767]	88	
P17	Multi-pump pressure differential gain 2	[0,32767]	0	
P18	Multi-pump pressure proportional gain 3	[0,32767]	8000	
P19	Multi-pump pressure integral gain 3	[0,32767]	88	
P20	Multi-pump pressure differential gain 3	[0,32767]	0	
P21	ECAT synchronization mode	0: Free operation 1: Sync manager interruption 2: Sync clock	0	
P22	ECAT synchronization time	0: 500us 1: 1ms 2: 2ms 3: 4ms	1	
P23	485 local communication address	[1,255]	10	
P24	485 communication check mode	0: (N,8,1) 1: (E,8,1) 2: (O,8,1) 3: (N,8,2) 4: (E,8,2) 5: (O,8,2)	0	N: No check bit; E: Even parity; O: Odd parity; 8-bit data; 1/2-bit stop bit;
P25	485 communication baud rate selection	0: 9600bps 1: 19200bps 2: 38400bps 3: 57600bps 4: 115200bps	1	

Code	Definition and Instruction	Parameter Range	Default Value	Unit
P26	CANOpen communication node number	[1,127]	32	
P27	CANOpen communication baud rate	0: 1000kbps 1: 500kbps 2: 250kbps 3: 125kbps 4: 50kbps 5: 20kbps	1	

※ See [5.3.4](#) for parameter instructions.

Chapter 6 Motor Parameter Autotuning

There are two kinds of motor parameter autotuning mode: static and dynamic.

Static mode: the motor parameter value is calculated based on motor voltage equation by motor nameplate parameters, namely resistor, inductance and flux linkage. Therefore, the precision of motor parameter is based on the accuracy of nameplate parameters.

Dynamic mode: It is necessary to rotate the motor to a certain speed, the large load may impact the precision of the motor parameter test, therefore, no-load or light-load of motor is required during test.

Motor nameplate parameter and parameter autotuning mode:

F70	Rated motor voltage	[0,800]	V
F71	Rated motor current	[0,900]	A
F72	Rated motor speed	[0,6000]	rpm
F73	Rated motor frequency	[0,600]	HZ
F74	Motor counter-emf	[0.0,800.0]	V/Krpm
E12	Diagnosis enable	0: Disable 1: Enable	
E14	Motor parameter autotuning (effective only after diagnosis enable is started)	0: Disable 1: Static 2: Dynamic	

Motor parameter autotuning test flowchart:

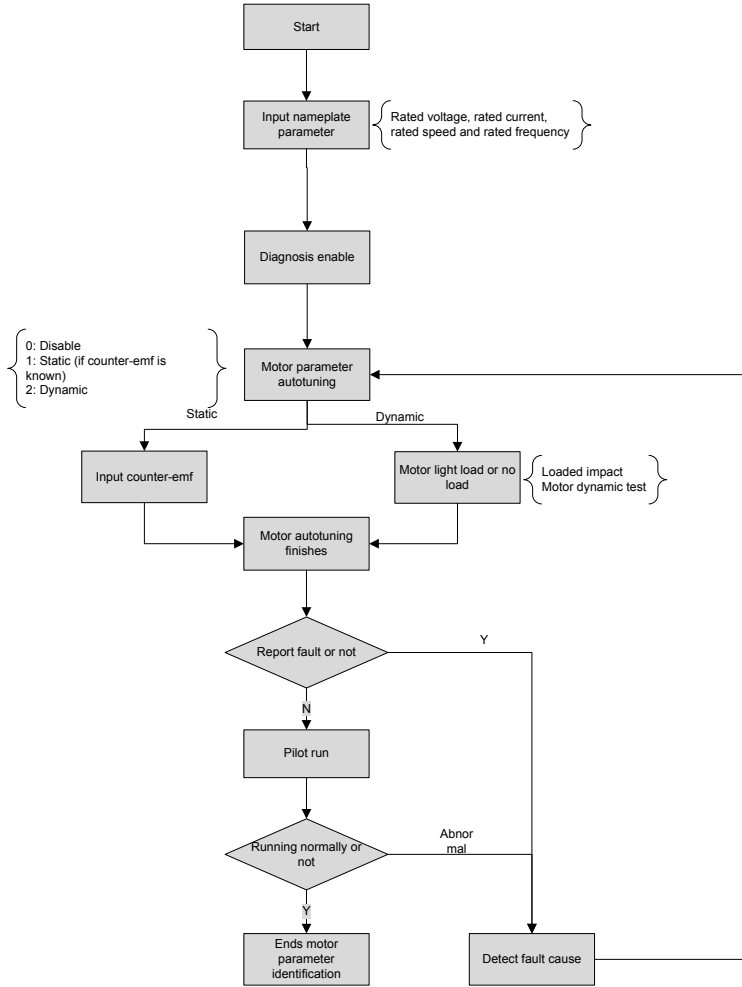

Chapter 7 Oil Pump Control

7.1 Oil Pump Control Mode Overview

Servo drive oil pump control mode is to change the AC servo motor speed based on the pressure inputted from external control system, flow command and feedback signal of pressure sensor, thus controlling the output pressure and flow of the oil pump. The pressure control forms a closed-loop PID control through the pressure sensor signal installed on the oil outlet port of the oil pump, while the flow control changes the flow discharged by the pump through controlling pump speed.

The basic schematic for oil pump is as below:

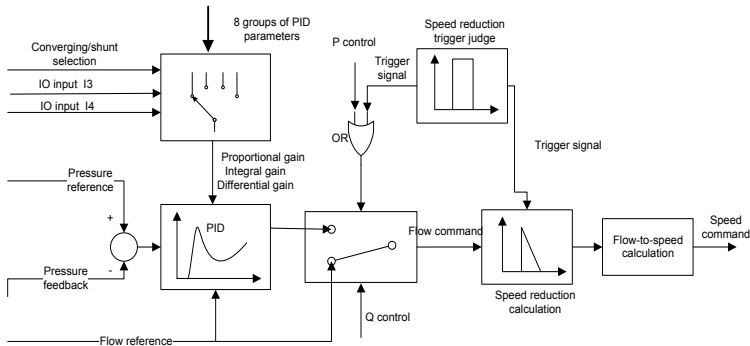

7.2 Common Pressure Priority Control (P Control)

The oil pump performs flow control when the feedback pressure fails to reach the reference pressure to make sure the output flow of the pump can change with the flow reference quickly and accurately. The output flow of the pump is in positive proportion to the motor speed, therefore the motor speed command is determined by the flow reference. When entering pressure control, it is required the pressure feedback of the system can change with the pressure reference quickly and accurately, while pressure feedback changes with the motor speed, thus the motor speed command is determined by pressure PID regulator.

In actual hydraulic pressure system, the oil pump control needs to switch between two kinds of control frequently, which requiring small pressure overshoot, quick switching speed and small vibration during switching. Users can optimize flow control, pressure control and switching control via adjusting speed proportional gain, speed integral gain, pressure proportional gain, pressure integral gain and pressure differential gain.

Commissioning parameter table for pressure priority control:

LED Display Code	Parameter Name	Function Instruction	Initial Value
F14	Speed proportional gain	Increase speed proportional gain can improve the transient response of motor speed control, improve motor speed stability and control the	When selecting different

LED Display Code	Parameter Name	Function Instruction	Initial Value
		interference; however, if it is set to a too large value, vibration may occur.	pumps
F15	Speed integral gain	Increase speed integral gain can reduce speed regulation deviation and control overshoot; however, if it is set to a too large value, vibration may occur.	
F19, F22 F25, F28	Pressure proportional gain 0_3	Increase pressure proportional gain can improve the transient response and stability of pressure control, control the interference and reduce pressure overshoot; however, if it is set to a too large value, vibration may occur.	13000
P09, P12 P15, P18	Multi-pump pressure proportional gain 0-3		8000
F20, F23 F26, F29	Pressure integral gain 0-3	Increase pressure integral gain can improve response speed of pressure control, reduce pressure control deviation, however, it will also increase pressure overshoot. If it is set to a too large value, vibration may occur.	100
P10, P13 P16, P19	Multi-pump pressure integral gain 0-3		88
F21, F24 F27, F30	Pressure differential gain 0-3	The larger the differential value, the smaller the overshoot during switching to pressure control; however, if it is set to a too large value, the voltage regulation deviation characteristic will be deteriorated and vibration may occur.	0
P11, P14 P17, P20	Multiple pressure differential gain 0-3		0

7.3 Flow Priority Control (Q Control)

In cases where pressure reference is low, the rising speed of flow command will be impacted by pressure reference, in the meantime, during flow control; the pressure feedback will also make an impact on the flow command when it rises quickly to a value close to the reference pressure. Flow priority control can be applied in cases where it is required that the flow command should not be impacted by the pressure reference and pressure feedback during flow control. During flow control, flow reference acts as the flow command of the system, the condition for flow control to be switched to pressure control can be changed via parameters, during switching, users can reduce pressure overshoot via pressure trigger control.

- ※ The default setting of the drive is pressure priority control, while the flow priority control can be commissioned only by the SCM of the PC of our company.

Commissioning parameter table of flow priority control:

Parameter Name	Function Instruction	Initial Value	Unit
Control mode	P mode is pressure control priority mode, Q mode is flow control priority mode	P control	
Trigger	When switching from flow control to pressure control, the	200	rpm

Parameter Name	Function Instruction	Initial Value	Unit
integral value	pressure trigger controls the set motor speed.		
Trigger mode	Set whether to use pressure trigger control function when switching from flow control to pressure control.	No trigger	
Pressure differential trigger threshold	The pressure rising speed condition for entering pressure trigger state	10	bar/ms
Enter trigger coefficient 1	The upper limit of the ratio between feedback pressure and reference pressure when entering pressure trigger state	90	%
Enter trigger coefficient 2	The lower limit of the gap between reference pressure and feedback pressure when entering pressure trigger state	10	bar
Exit trigger coefficient 1	The lower limit of the ratio between feedback pressure and reference pressure when exiting pressure trigger state	80	%
Exit trigger coefficient 2	The upper limit of the gap between the reference pressure and feedback pressure when exiting pressure trigger state	15	bar

7.4 Dual-Displacement Pump Control

Dual-displacement plunger pump can switch between big/small swash plates by switching on/off the coil, thus changing the displacement of the pump. Big swash plate dig angle is used in large flow output demand while small swash plate dip angle is used in small pressure output or pressure-hold, thus improving pressure control performance and reducing energy consumption. There are two control modes for the dual-displacement pump swash plate switching: over-pressure switching, hold pressure/over-pressure switching.

Over-pressure switching mode: When the system feedback pressure is larger than the displacement switching pressure threshold and the motor speed is smaller than the lower limit of switching speed, switch to small swash plate dig angle; when the motor speed is larger than the displacement switching speed, switch to big swash plate dip angle.

Over-pressure switching mode during holding pressure: Connect the injection input signal of upper control system to the digital input signal I6 (CN3-12) of the drive, if the input is high, it means the injection molding machine is working in injection pressure-hold state, and if in the meantime, the feedback pressure reaches pressure reference value or exceeds displacement switching pressure threshold and the motor speed is less than the lower limit of the displacement switching speed, switch to small swash plate dig angle; if the motor speed exceeds the upper limit of displacement switching speed or digital input signal I6 input is low, switch to big swash plate dip angle.

When switching to small swash plate dip angle, the drive will compensate the motor speed command according to the displacement ratio to keep the oil output flow constant.

Commissioning parameter table for dual-displacement pump control:

LED Display	Parameter	Function Instruction	Initial Value	Unit
-------------	-----------	----------------------	---------------	------

Code	Name			
F45	Plunger pump model selection	Plunger pump model selection	0: Single displacement	0: Single displacement 1: Dual displacement
F46	Plunger pump displacement ratio	Displacement ratio between small swash plate dip angle and big swash plate dip angle	30	%
F47	Wobble plate pressure switching threshold	The feedback pressure threshold when the system switches to small swash plate dip angle	195	bar
F48	Wobble plate pressure judging delay	The continuous time condition for the feedback pressure to be larger than wobble plate pressure switching threshold when switching to small swash plate dip angle.	100	ms
F56	Wobble plate switching rising delay	Speed compensation delay when big swash plate dip angle switches to small swash plate dip angle	10	ms
F57	Wobble plate switching declining delay	Speed compensation delay when big swash plate dip angle switches to big swash plate dip angle	10	ms
F58	Upper limit of speed switching	Motor speed threshold when switching to big swash plate dip angle	1200	rpm
F59	Lower limit of speed switching	Motor speed threshold when switching to small swash plate dip angle	200	rpm
F65	Displacement switching mode	0: Over-pressure 1: Over-pressure during pressure-hold	0: Over-pressure	

Chapter 8 Multi-pump Parallel Control

The hydraulic-pressure control of the injection molding machine with large tonnage is limited by the oil pump displacement or motor power, therefore, the single pump system is far from satisfying the flow demands, it is a must to connect in parallel the oil outlets of multiple single pump systems to realize converging and obtain large flow. In converging system, in order to improve productivity and shorten the process cycle, it is necessary to complete two or more actions at the same time, which requires the hydraulic pressure system carrying single circuit to be divided into dual-circuit or three-circuit hydraulic system that can be controlled separately, and each circuit can perform flow and pressure control independently during shunt control, while during converging control, pressure control and system total flow control is performed by only one main drive, and other drives converts to the flow command of each circuit via flow distribution calculation based on the system total flow command of the main drive. The system total output flow is the flow sum of the oil pump output of each circuit system.

8.1 Multi-pump Mode

When the converging type of each node (single pump system) is set to multi-pump, each node can work in converging control only. The main node is used to receive the pressure and flow reference and running enable signal of the upper control system as well as the pressure sensor signal of the system oil outlet port, then carry out pressure and system total flow control. The slave node converts to speed command to perform speed control based on the system total flow command sent by CAN communication according to below flow distribution algorithm.

The flow distribution mode when converging type is multi-pump or composite:

Each node has its own max private flow, namely the max flow that can be withstood by the node alone.

Max private flow=max node flow*flow cut-in threshold ratio

For total flow command of reference system, if it is less than the max private flow of main pump 0, the main pump 0 bears all the system flow needs; if it is larger than that of the main pump 0, main pump 0 provides its max private flow while the residual flow is provided by the slave pump; when the residual flow needs is less than the max private flow of slave pump 1, the slave pump 1 bears all the residual flow; when it is larger than that of the slave pump 1, slave pump 1 provides its max private flow, and the residual flow needs will be provided by the slave pump, continue by that analogy until the residual energy is fully consumed by the remaining slave pumps. If the max private flow of the last slave pump is less than the residual flow, namely the max private flow sum of all the pumps cannot fully consume the system flow needs, the system flow needs will be distributed evenly (based on the ratio) to all the pumps.

1) System diagram of multi-pump mode:

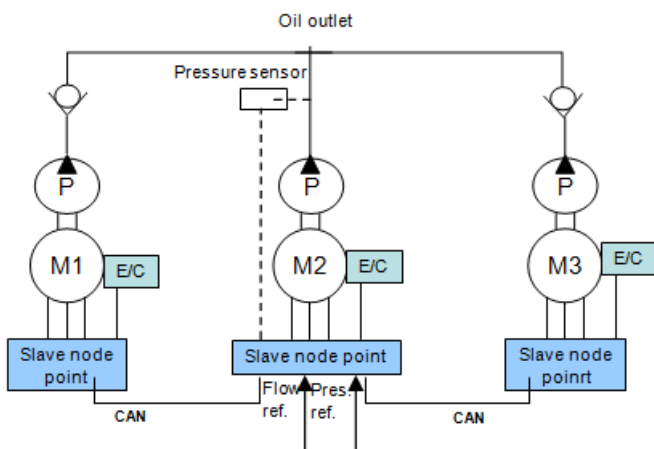

2) Multi-pump wiring diagram:

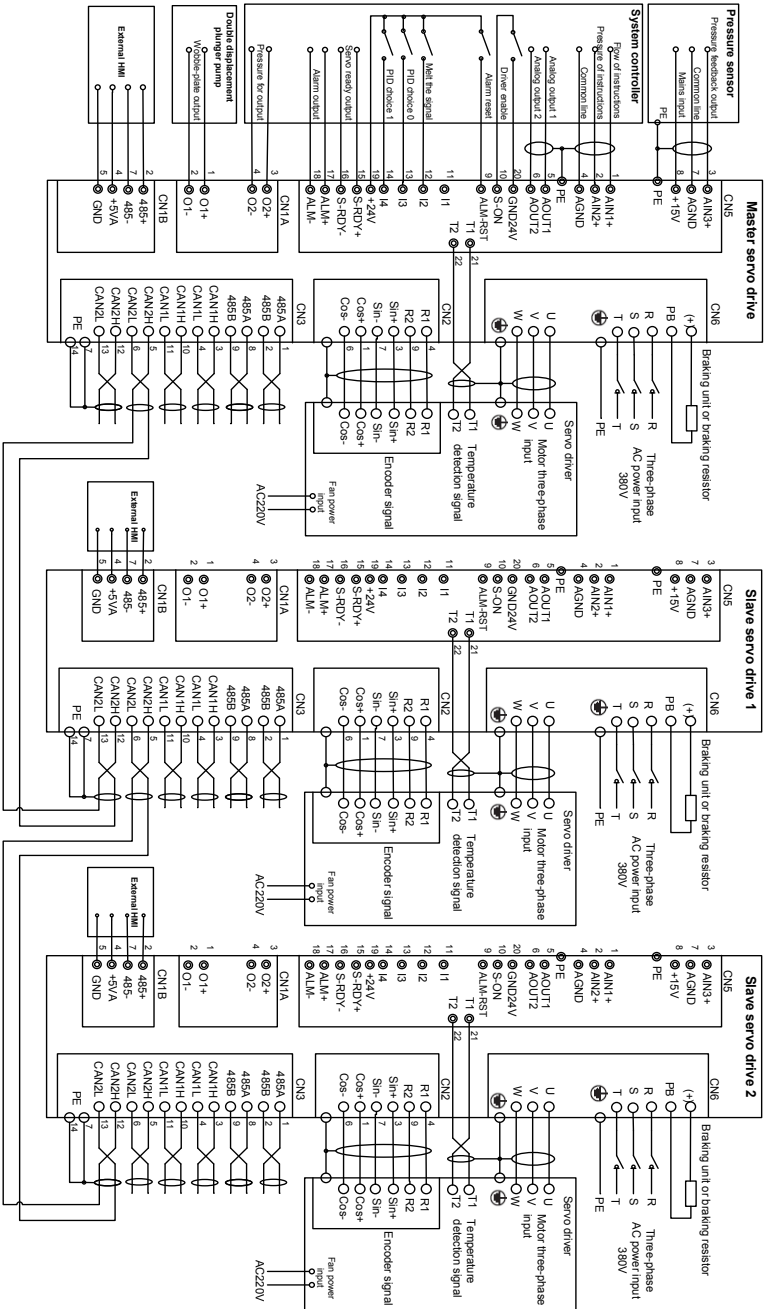

8.2 Composite Mode

The system has two kinds of control modes, namely converging and shunt. The control mode of each node can be switched by digital input I1 (C/D). In shunt mode, each node acts as the single-circuit hydraulic pressure system to complete flow and pressure control, while for converging mode, which is the same as multi-pump mode, the main node completes pressure control and system total flow control, and the slave node converts to speed command based on the system total flow command sent by CAN communication according to above flow distribution algorithm.

1) System diagram for composite mode

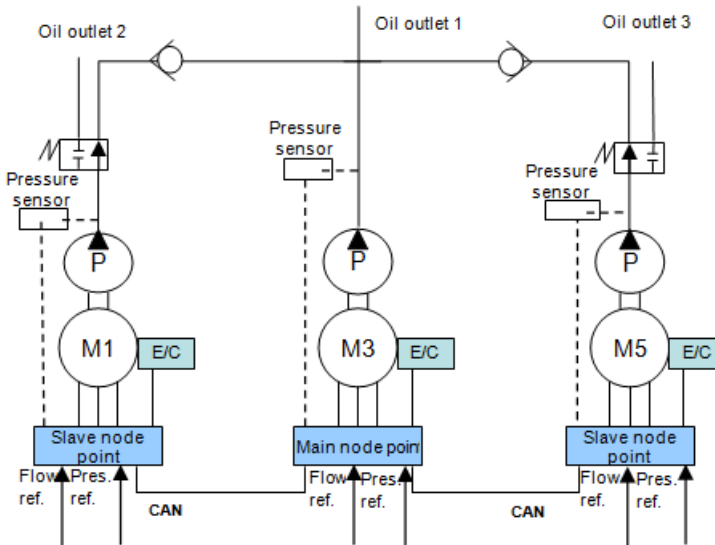

8.3 Multi-mode

The system is comprised of three nodes and each node is comprised of one or more single pump systems. The single pump system is called control unit and the node constituted by one control unit is an independent unit node. The multi-unit node comprised of multiple control units can be taken as a node constituted by double-pump or multiplex pump, while multi-unit mode is comprised of one control unit and one or more following units, the node carries a pressure sensor to connect to the control unit and the control unit connects to the upper control system via AIN1 and AIN2, thus receiving the pressure and flow reference signal. The two DA outputs of control unit is connected to the AIN1 and AIN2 of the following unit respectively to act as the motor speed reference signal and drive enable signal. The RDY output ports of the following unit are connected in serial with positive end connecting to 24V power and negative end connecting to I7 of control unit. The control unit obtains the running state of the following unit drive via this digital input port.

Each node uses I1 (C/D) to switch the control mode. When I1 is high, the node works in converging state and if it is low, the node works in shunt state. When the system operates in converging state, the

node number of converging can be changed, and the main node completes pressure control and system total flow. The slave node working in converging mode operates in the same speed with the main node. Above flow distribution algorithm is not used during multi-mode. The control unit of each node performs pressure control and flow control respectively in shunt mode, and the following unit and control unit keeps operating in the same speed.

System diagram for multi-mode:

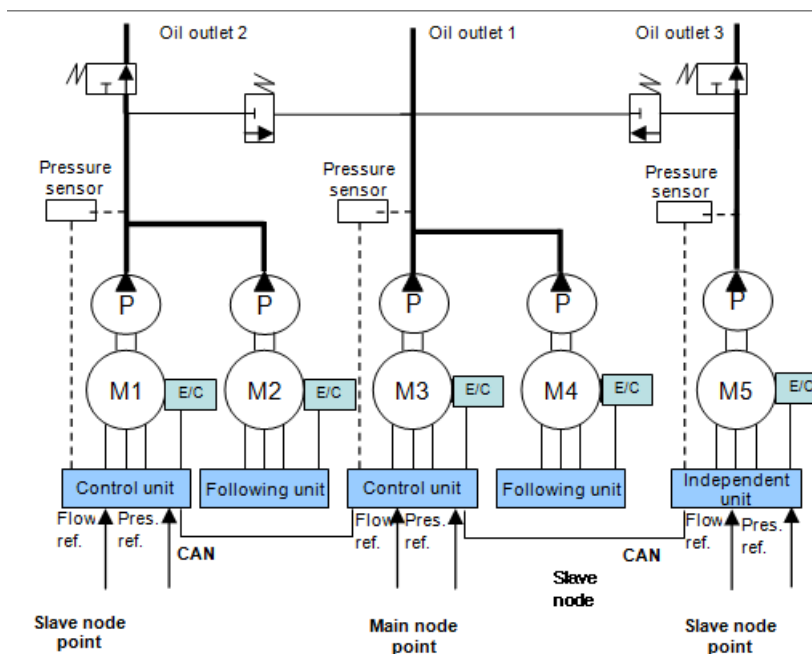

Wiring diagram for composite mode and multi-mode:

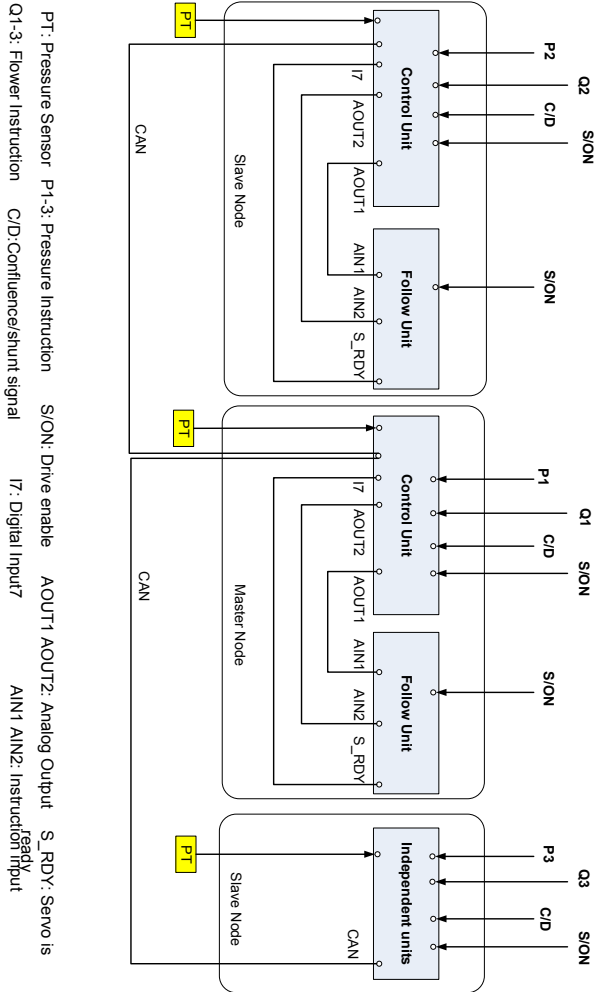

Commissioning parameter table for multi-pump parallel control:

LED Display Code	Parameter Name	Function Instruction	Initial Value	Unit
P00	Network enable	Network enable control: Set properly the parameters to be used by the single pump of each node and the converging type and node number. The main node needs to be set with proper slave node number, flow cut-in threshold and	0: Disable	

LED Display Code	Parameter Name	Function Instruction	Initial Value	Unit
		upper/lower limit of flow cut-in hysteresis. After all the settings are done, executing the network enable commands in sequence (slave node first, main node last). 0: Disable; 1: Enable		
P01	Drive enable on the network	Control the disable/enable of the drive of all nodes, suitable for multi-pump mode 0: Disable; 1: Enable	0: Disable	
P02	Converging type	Select converging type 0: Single pump; 1: Composite; 2: Multi-pump; 3: Multi-mode	0: Single pump	
P03	Node number	If node number is 0, it means master If node number is 1 – 15, it means slave	0	
P04	Slave node number	If node number is 0, the slave number means the number connected to this master	0	
P05	Node type	Set the mode for the drive to work in the node 0: Independent unit; 1: Control unit 2: Following unit; 3: Flow loop unit	0: Independent unit	
P06	Flow cut-in threshold	The condition for the next pump to engage: serves to make the next pump to engage when the system flow exceeds the flow cut-in threshold of present pump,	25	%
P07	Upper limit of flow cut-in hysteresis	The condition for the next pump to engage: serves to prevent repeated start/stop of the pump which is caused by the flow's staying in the threshold point.	5	%
P08	Lower limit of flow cut-in hysteresis	The condition for the next pump to engage: serves to prevent repeated start/stop of the pump which is caused by the flow's staying in the threshold point.	2.5	%
P09	Multi-pump pressure proportional gain 0	0 th step of the proportional parameter of multi-pump pressure PID control	8000	
P10	Multi-pump pressure integral	0 th step of the integral parameter of multi-pump pressure PID control	88	

LED Display Code	Parameter Name	Function Instruction	Initial Value	Unit
	gain 0			
P11	Multi-pump pressure differential gain 0	0 th step of the differential parameter of multi-pump pressure PID control	0	
P12	Multi-pump pressure proportional gain 1	1 st step of the proportional parameter of multi-pump pressure PID control	8000	
P13	Multi-pump pressure integral gain 1	1 st step of the integral parameter of multi-pump pressure PID control	88	
P14	Multi-pump pressure differential gain 1	1 st step of the differential parameter of multi-pump pressure PID control	0	
P15	Multi-pump pressure proportional gain 2	2 nd step of the proportional parameter of multi-pump pressure PID control	8000	
P16	Multi-pump pressure integral gain 2	2 nd step of the integral parameter of multi-pump pressure PID control	88	
P17	Multi-pump pressure differential gain 2	2 nd step of the differential parameter of multi-pump pressure PID control	0	
P18	Multi-pump pressure proportional gain 3	3 rd step of the proportional parameter of multi-pump pressure PID control	8000	
P19	Multi-pump pressure integral gain 3	3 rd step of the integral parameter of multi-pump pressure PID control	88	
P20	Multi-pump pressure differential gain 3	3 rd step of the differential parameter of multi-pump pressure PID control	0	

Chapter 9 Running Commissioning

MH800 series hydraulic pressure servo system supports two kinds of commissioning modes to satisfy different customer demands: commissioning via the external HMI (optional) which adopts 5.7 inch LCD and user-friendly interface or commissioning by the built-in LED panel of the servo drive.

9.1 Commissioning Flowchart

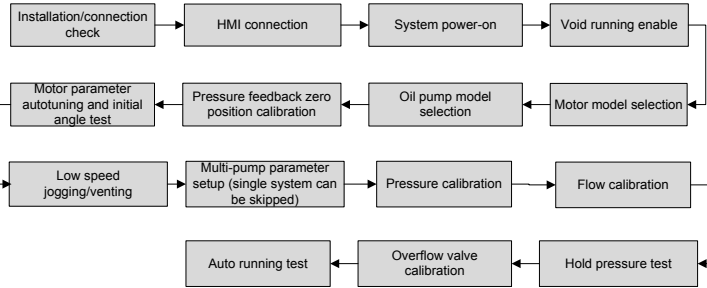

9.2 Commissioning Procedures

The following commissioning instruction describes the operation procedures of HMI commissioning system. For commissioning via LED panel, refer to [5.4](#) for details.

9.2.1 Commissioning Preparations

1) Installation confirmation

Check the connections of each terminal, confirming all the parts needing to be fixed are fixed firmly and no loose thread occur.

2) HMI connection

MH800 series servo electro-hydraulic system supports hot-plugging of HMI. Just insert the DSUB9 terminal of HMI into the CN1B terminal on the front cover of the drive to connect the HMI to the drive. (This procedure is skipped if commissioning via LED panel).

3) Void enable

In order to ensure system safety during commissioning, it is required to void the enable of the system before powering on 3-phase AC and commissioning. There are two ways to void enable when HMI is not connected:

Method 1: Disconnect the connection wire of the drive enable terminal;

Method 2: If the upper PC of the injection molding machine carries system enable function and the enable output is connected to the enable terminal of the drive, users just need to void the system enable.





9.2.2 Motor Model Selection



1) Motor model selection mode

Refer to motor model list in [5.5.5](#): use  and  key to switch to “set” mode, and stop the

highlighted cursor at “motor selection” item via  and  key, then press  key to access.

Monito	Setting	Tuning
Drive Type	CT-7501-A-0	
Motor Type	U1004F.15.3	
Pump Type	SETTIMA 28mL/r	
P. Sensor Zero		
P. Cal. Mode	Linear	
Q. Cal. Mode	Linear	
Sys Stats: Ready (Tech.) P: 0.0		
S: 0	T: 0	R: 2100

Use  and  key to stop the highlighted cursor at the motor model number item, and change the value to the corresponding number of the motor via  and  key. (See motor nameplate for detailed model, the figure above takes “K036N20A11” as an example)

Then, stop the highlighted cursor sat the “save” item via  and  key, and press  key to save and exit to the setup menu column, HMI will transmit present motor parameter to the drive. The right side of motor selection menu will display “parameter programming”, and displays motor model “K036N20A11” after parameter programming is finished.

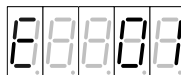

Parameter Settings	
Motor Type	
K036F20C18P	
0 0 1	
Save	Cancel
Sys Stats: Ready (Tech.) P: 0.0	
S: 0 rpm	T: 0 Nm R: 2100

LED panel commissioning setup parameter:







9.2.3 Pump Model Selection

1) Pump model selection mode

Refer to Oil pump model list in [5.5.5](#), stop the highlighted cursor at the “pump selection” item via  and , and press  to enter.

Monito	Setting	Tuning
Drive Type		CT-7501-A-0
Motor Type		U1004F.15.3
Pump Type		SETTIMA 28mL/r
P. Sensor Zero		
P. Cal. Mode		Linear
Q. Cal. Mode		Linear
Sys Stats: Ready (Tech.) P: 0.0		
S: 0	T: 0	R: 2100

First, use  and  key to stop the highlighted cursor at the corresponding number, then change this number to the corresponding value of pump model via  and  key. (See the pump nameplate for detailed model, the figure above takes “PUMP 28mL/r” as an example)

Then, stop the highlighted cursor at “save” via  and , and press  key to exit to the setup menu column, the HMI will transmit present pump parameters to the drive.

The right side of the “pump selection” menu will display “parameter programming”, then display pump model “PUMP 28mL/r” after parameter programming is done.

Parameter Settings	
Pump Type	
PUMP 28mL/r	
0 1	
Save	Cancel
Sys Stats: Ready (Tech.) P: 0.0	
S: 0 rpm	T: 0 Nm R: 2100

LED panel commissioning setup parameter:



If the selected pump is not in the model list, it is necessary to reset. In setup menu, adjust pump displacement (reset) [F31] and pump leakage (reset) [F32].

The following setup 9.2.3(2)→9.2.3(12)can be skipped when system configuration is the same with the default value.

2) Backpressure mode selection [F43] (the default value is manual backpressure)

- a) Automatic: Storing mode is electronic backpressure
- b) Manual: Storing mode is manual backpressure

3) Pressure sensor model selection [F44] (default value is 10V)

a) 5V: The drive sampling voltage range is 0 – 5V, sensor output range is 1 – 5V, measuring range is 0 – 200bar;

b) 10V: The drive sampling voltage range is 0 – 10V, sensor output range is 0 – 10V, measuring range is 0 – 250bar.

4) Plunger pump type selection [F45] (default setting is single-displacement plunger pump)

a) Dual-displacement: dual-displacement plunger pump

b) Single-displacement: single-displacement plunger pump

5) Plunger pump displacement ratio [F46] (single-displacement plunger pump is skipped)

Parameter value is the ratio between small displacement and large displacement.

6) Wobble plate switching mode [F65] (single-displacement plunger pump is skipped)

Set displacement switching mode.

7) Wobble plate switching pressure threshold [F47] (single-displacement plunger pump is skipped)

Set displacement switching pressure threshold

8) Wobble plate pressure judging delay [F48] (single-displacement plunger pump is skipped)

Set wobble plate switching pressure delay

9) Wobble plate switching rising delay [F56] (single-displacement plunger pump is skipped)

Set displacement switching rising delay

10) Wobble plate switching declining delay [F57] (single-displacement plunger pump is skipped)

Set displacement switching declining delay

11) Upper limit of speed switching [F59] (single-displacement plunger pump is skipped)

Set upper limit of speed switching

12) Lower limit of speed switching [F59] (single-displacement plunger pump is skipped)

Set lower limit of speed switching

13) Multi-step pressure PID setting

If the system need to use different pressure PID parameters to perform stepwise control in different steps, first, connect I3 (CN3-9)and I4(CN3-10)and take them as the indication signals for control step, then set the PID parameter of the corresponding step (four steps in total). The relation between digital input signal and each step of pressure PID is shown below:

Pressure Control PID Selection during Single Pump Mode: Pressure PID Parameter				
I4	I3	KP number	KI number	KD number
low	low	0	0	0
low	high	1	1	1
high	low	2	2	2
high	high	3	3	3



9.2.4 Pressure Feedback Zero Position Calibration Mode

Under setup mode, stop the highlighted cursor at “pressure feedback zero position calibration” item

via  and  key, then press  key to enter the setup interface of this item.

Monito	Setting	Tuning
Drive Type		CT-7501-A-0
Motor Type		U1004F.15.3
Pump Type		SETTIMA 28mL/r
P. Sensor Zero		
P. Cal. Mode		Linear
Q. Cal. Mode		Linear
Sys Stats: Ready (Tech.) P: 0.0		
S: 0	T: 0	R: 2100

Adjust the pressure in the system oil circuit to “0” (subject to the pressure gauge of the injection molding machine) before carrying out pressure feedback zero position calibration.

Stop the highlighted cursor at “save” via  and  key, then press  key to return to the setup menu column, and the “pressure feedback zero position calibration” item will display “calibrating”, when “calibrating ” disappears, it means calibration is done.

Parameter Settings

The zero calibration
pressure feedback

Save **Cancel**

Sys Stats: Ready (Tech.) P: 0.0
S: 0 rpm T: 0 Nm R: 2100

LED panel commissioning setup parameter:







9.2.5 Motor Parameter Autotuning and Motor Initial Angle Measurement

If the motor used is not listed in 5.5.4 motor model list, motor parameter autotuning will be required. The autotuning procedures are shown below:

- 1) Set motor parameters:

Use HMI or LED commissioning panel to set in setup menu the rated motor voltage [F70], rated motor current [F71], rated motor speed [F72], rated motor frequency [F73], motor counter-emf [F74] and motor temperature sensor [F75].

- 2) Diagnosis function “Enable”

Use  and  key to switch to “commissioning mode”, and stop the highlighted cursor at “diagnosis function” item via  and  key, then press  key to change the “diagnosis function” state to “enable”.

Monitor	Setting	Tuning
Operating Enable		
Diagnosis Enable		Enable
Controller Check		Disable
Measure Angle		Disable
Jog Enabled		Disable
Motor S.L. Way		Disable
Sys Stats: Ready (Tech.) P: 0.0Bar		
S: 0 rpm T: 0 Nm R: 2100		

LED panel commissioning setup parameter:



3) Motor parameter autotuning

Set motor parameter autotuning [E14] parameter.

0: Disable, do not carry out motor parameter autotuning;

1: Static, carry out in cases where motor counter-emf is known, and the motor does not rotate during measuring; can be performed without turning on the overflow valve;

2: Dynamic, adopted in cases where motor counter-emf is unknown, and the motor runs at high speed during measuring, it is recommended to turn on the overflow valve as measuring with load may impact the precision of motor parameter measuring and the control effect, meanwhile, it may cause high voltage in the oil circuit which is a safety danger.

If LED commissioning is used, after setup, the LED will display “———”, after measurement completes, the motor parameter autotuning [E14] parameter on the LED will revert to 0 automatically. If HMI commissioning is used, after setup is done, the right side of “motor parameter autotuning” will display “auto-measuring”; after measurement, the right side of “motor parameter autotuning” displays “succeed”, then it will be switched to “disable” state automatically.

If the drive alarms during test, users should analysis the fault cause and rule out the problem to proceed with motor parameter autotuning.

LED panel commissioning setup parameter:



4) Motor initial angle test

When motor brands other than KINWAY is adopted, it is necessary to measure the motor initial angle again.

If motor parameter autotuning is completed, motor initial angle test is not needed.

After entering commissioning interface, stop the highlighted cursor at “measuring initial angle” item via ▲ and ▼ key, and press 确认 key to make it in “enable” state.

Monitor	Setting	Tuning ▶
Operating Enable		
Diagnosis Enable		Enable
Controller Check		Disable
Measure Angle		Disable
Jog Enabled		Disable
Motor S.L. Way		Disable
Sys Stats: Ready (Tech.) P: 0.0Bar		
S: 0 rpm T: 0 Nm R: 2100		

After setup, the system will measure the initial angle automatically; the right side of the “measuring initial angle” displays “auto-measuring”.

Monitor	Setting	Tuning ▶
Operating Enable		
Diagnosis Enable		Enable
Controller Check		Disable
Measure Angle		Self-test
Jog Enabled		Disable
Motor S.L. Way		Disable
Sys Stats: Ready (Tech.) P: 0.0Bar		
S: 0 rpm T: 0 Nm R: 2100		

After measurement is done, the right side of “measuring initial angle” displays “succeed” and the measurement result will be displayed in “resolver offset quantity”, then it will be switched to “disable” state.

LED panel commissioning setup parameter:





After entering “measure initial angle” menu, LED will display “READY”, press SET key to measure the initial angle automatically, LED displays " ———— ". After measuring is done, LED displays “OK”.



The operator should save the measurement value into EEPROM via the parameter programming function in the setup menu, and save the latest calibration state into EEPROM via “parameter programming” function in the setup menu, otherwise, the calibration state will revert to the state

before calibration.

The programming procedures are shown below:

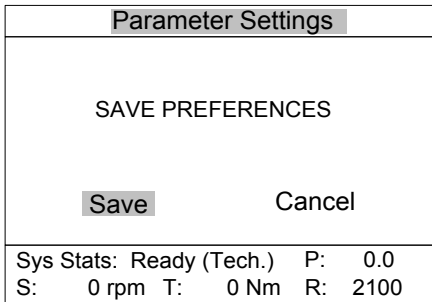
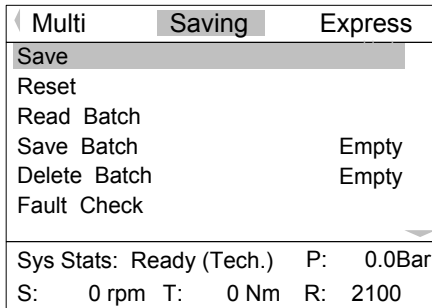
Under parameter programming mode, stop the highlighted cursor at the “parameter programming” item via  and  key, then press  key to enter “parameter programming” setup interface”.



Stop the highlighted cursor at the “confirm” via  and  key, then press  key to return to “parameter programming” interface, and the right side of the parameter programming item will display “in programming”. When “in programming” disappears, it means programming is completed.

LED panel commissioning setup parameter:





9.2.6 Low Speed Jogging and Venting

The test aims to check whether basic functions of the electro-hydraulic system operation are normal.







1) Inspection and preparation before operation

During running the servo system for the first time, it is a must to check the circuit connection of hydraulic pressure and electrical connection of servo system beforehand; oil pump displacement and operation pressure valve should be the same with those on the nameplate. First, adjust the system to the state where the oil discharged by the pump returns to the oil chamber directly; for instance, adjust the overflow pressure of the overflow valve to the min

value. Note: Do not start the machine when shut-off is applied to the output side of the oil pump.

- 2) Low speed light-load operation
- a) Turn on jogging enable to adjust the max jogging speed. After entering commissioning interface, stop the highlighted cursor at “jogging enable” item via  and  key, and press  key to make it in “enable” state.

Monitor	Setting	Tuning
Operating Enable		
Diagnosis Enable		Enable
Controller Check		
Measure Angle		
Jog Enabled		Enable
Motor S.L. Way		Technical
Sys Stats: Ready (Tech.) P: 0.0Bar		
S: 0 rpm T: 0 Nm R: 2100		

After adjustment is done, the operator can make the motor rotate forward or backward via  and  key, and keeping  and  pressed down can accelerate the motor to the max jogging speed in positive or negative direction (use  and  key for LED panel commissioning).

LED panel commissioning setup parameter:



Confirm the working condition

When motor rotates forward, confirm that the rotation direction of the pump is the same with the arrow direction on the pump label; confirm the noise and vibration is within normal range and the pump can suck oil normally.

Error	Phenomenon	Solution
Error 1	The motor does not rotate and the torque value is large.	Enter setup menu to change motor rotation direction. Perform step 8.2.5 – 8.2.6(2)(b)again
Error 2	The rotation direction of the pump differs from the arrow direction on the pump label.	Enter setup menu to change motor rotation direction and resolver direction. Perform step 8.2.5 – 8.2.6(2)(b)again

- b) Venting

Confirm above-mentioned 9.2.6(2)(b)is normal and make the pump rotate forward to vent all the air inside the hydraulic pressure system.

Note: At the beginning of startup, abnormal noise may occur as there is air mixed in the hydraulic pressure oil, which is normal phenomenon; however, if the abnormal noise persists in a period of time, users must vent the air in the hydraulic pressure oil circuit.

- c) Void jogging enable and diagnosis enable

Refer to the modification mode in 9.2.6(2)(a) to disable the “jogging enable”, then refer to the modification mode in 9.2.5(2) to change the state of “diagnosis function” to “disable”.

Monitor	Setting	Tuning
Operating Enable		Disable
Diagnosis Enable		Disable
Controller Check		
Measure Angle		
Jog Enabled		
Motor S.L. Way		Technical
Sys Stats: Ready (Tech.) P: 0.0Bar		
S: 0 rpm T: 0 Nm R: 2100		

LED panel commissioning setup parameter:

Press MODE key to make LED exit from jogging state. The exit diagnosis state needs to set the parameter below.



Multi-pump parameter setup (if the system is single-pump system, this procedure can be skipped)

1) Converging type setup

Use ◀ and ▶ key to switch to “multi-pump”, then stop the highlighted cursor at “converging type” item via ▲ and ▼ key, then press 确认 key to enter setup menu.

Multi	Saving	Express
NET Control		Disable
NET IPM Control		Disable
Merged Flow Type		Single
Node ID		0
Slave Sum		0
Node Type		Single Unit
Sys Stats: Ready (Tech.) P: 0.0Bar		
S: 0 rpm T: 0 Nm R: 2100		

Use ◀ and ▶ key to stop the highlighted cursor at type selection, then change the converging type to the type needed via ▲ and ▼ key (in above figure, “multi-pump” is taken as an example).

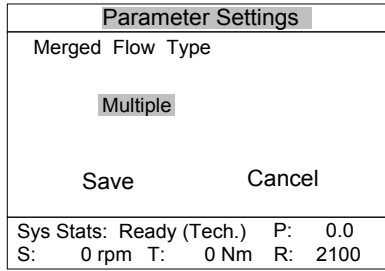

Then, stop the highlighted cursor at “save” via and key, press key to save and exit to multi-pump menu column, then the right side of converging type menu will display the selected type (in above figure, “multi-pump” is taken as an example).

LED panel commissioning setup parameter:



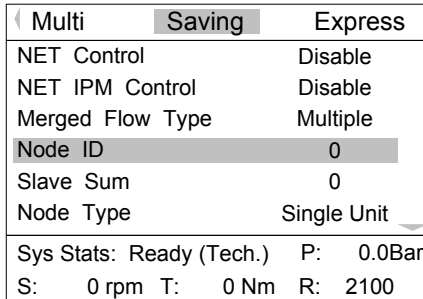

2) Node number setup

Use and key to switch to “multi-pump”, then stop the highlighted cursor at “node number” item via and key, and press to enter the setup menu.



Use and key to stop the highlighted cursor at type selection, then set the node number via and key: set the main system node number to 0, set the slave system communication node number to “1”, “2”..... in order based on the quantity of slave systems (the main system “0” is taken as an example in the figure).



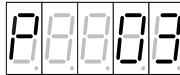

Parameter Settings	
Node ID	
00	
Save	Cancel
Sys Stats: Ready (Tech.) P: 0.0	
S: 0 rpm T: 0 Nm R: 2100	

Then, stop the highlighted cursor at “save” via  and  key, press  to save and exit to multi-pump menu column. The right side of the node number menu will display the node number of present system (“0” is taken as an example in the figure).





LED panel commissioning setup parameter:





3) Slave node number setup (no. 0 node needs to be set, other nodes are skipped)

Use  and  key to switch to “multi-pump”, then stop the highlighted cursor at “slave node number” via  and  key, and press  to enter setup menu.

Multi	Saving	Express
NET Control		Disable
NET IPM Control		Disable
Merged Flow Type		Multiple
Node ID		0
Slave Sum		0
Node Type		Single Unit
Sys Stats: Ready (Tech.) P: 0.0Bar		
S: 0 rpm T: 0 Nm R: 2100		

Use  and  key to stop the highlighted cursor at type selection, then set slave node number and the quantity of slave systems via  and  key (a slave system “1” is taken as an example in the figure)

Parameter Settings	
Slave Sum	
0 1	
Save	Cancel
Sys Stats: Ready (Tech.) P: 0.0	
S: 0 rpm T: 0 Nm R: 2100	

Use  and  key to stop the highlighted cursor at “save”, press  to save and exit to enter multi-pump menu column. The right side of slave node number menu will display the slave node number of present system (“1” is taken as an example in the figure).

LED panel commissioning setup parameter:



4) Multi-pump flow setup

Set “flow cut-in threshold” [P06], normally set to 25%;

Set “upper limit of flow cut-in hysteresis” [P07], normally set to 5%;

Set “lower limit of flow cut-in hysteresis” [P08], normally set to 2.5%

5) Network enable and drive enable setup

Network enable: Set “network enable/disable” [P00] respectively to perform network enable on the drive in the order of slave first and master last.

Drive enable on the network: This function is effective only when converging type is set to multi-pump mode, set “Drive enable” [P01] and perform motor enable operation on all the drives on the multi-pump parallel system.

6) Node type setup

When a certain node on the multi-pump parallel system is a multi-unit node comprised of multiple drives, it is necessary to set the “node type” [P05] parameter of all the drives on this node.

9.2.7 Pressure Calibration

Note: The calibration for “single pump”, “composite”, “multi-mode” or “multi-pump” differs from each other slightly.

- Single pump: Calibrate directly regardless of “network enable”[P00]parameter;
- Composite and multi-mode:

First, disable the “network enable” [P00] under “multi-pump” menu, then calibrate each node according to the calibration mode of single pump system.
- Multi-pump:

First, disable the “network enable” [P00] under “multi-pump” menu, and set the proper “max flow” [F13]and “max pressure” [F12] of each node, then perform network enable on the multi-pump parallel system according to the mode specified in 9.2.7(5), at this moment, the max system pressure takes the min value of the “max pressure” of the master and slave nodes, then carries out calibration according to below method.

Change the “operation enable” item to “disable” state, (in multi-pump type, change “drive enable” item [P01] to “disable” state)

Monitor	Setting	Tuning
Operating Enable		Disable
Diagnosis Enable		Disable
Controller Check		
Measure Angle		
Jog Enabled		
Motor S.L. Way		Technical
Sys Stats: Ready (Tech.) P: 0.0Bar		
S: 0 rpm T: 0 Nm R: 2100		

LED panel commissioning setup parameter:



1) Filter adjustment

Use and key to switch to setup mode, and stop the highlighted cursor at “pressure filter” item via and key, then press key to enter the setup interface of pressure filter.

Parameter Settings	
Pressure filter	
Analog input pressure	81.0
01	
Save	Cancel
Sys Stats: Ready (Tech.) P: 0.0	
S: 0 rpm T: 0 Nm R: 2100	

LED panel commissioning setup parameter:

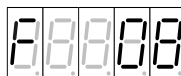

Adjust the upper PC pressure reference to 40%, observe the change of pressure analog input.

Improve the pressure filter parameter value gradually by setting parameters until the fluctuation of pressure analog input reaches the standard listed in below table.



Fluctuation of pressure analog input	≤0.2V	Measurement should be carried out during 40% of pressure reference
--------------------------------------	-------	--

2) Calibration

Purpose: The servo system can convert the analog reference of control system to actual requirements to carry out control only when the control system offers a reference point to the analog quantity of servo drive.

a) Set max pressure and pressure full range

The purpose of setting the max pressure is to avoid the reference of upper PC exceeds the upper limit of the system. For multi-pump type, this parameter has been set already and need not to be set again.

Under set mode, stop the highlighted cursor at “max pressure” item via  and  key and press  to enter its setup interface.

Modify the parameter value of the max pressure via setting value parameters. (165kg is taken as an example in the figure)

Parameter Settings	
P. Max.	
1 6 5	Bar
Save	Cancel
Sys Stats: Ready (Tech.) P: 0.0	
S: 0 rpm T: 0 Nm R: 2100	

Similarly, set the “pressure full range” to the required value (set 160kg as an example in the figure)

Parameter Settings	
P. Full Scale	
1 6 0	Bar
Save	Cancel
Sys Stats: Ready (Tech.) P: 0.0	
S: 0 rpm T: 0 Nm R: 2100	

LED panel commissioning setup parameter: Pressure full range and the max pressure can be

modified in LED panel by setting the pressure full range.



b) Linear calibration

Set “pressure calibration mode” to “linear calibration” via setting function parameters.

LED panel commissioning setup parameter:

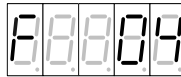

Stop the highlighted cursor at “linear pressure calibration” via and key and press to enter.

Stop highlighted cursor at linear pressure calibration point via and key, and adjust the item name to “zero position” via and key.

Stop the highlighted cursor at “save” via and key, change the pressure reference of upper PC to 0bar, and press key to return to setup mode menu.

Parameter Settings	
P. Cal. Linear	
P. Analog Input	3.72 V 0.327 A
Zero	
	Cancel
Sys Stats: Ready (Tech.) P: 0.0	
S: 0 rpm	T: 0 Nm R: 2100

If the state column of linear pressure calibration displays “succeed”, and then disappears, it means calibration is succeeded.

Monito	Setting	Tuning
P. Cal. Linear		Succeed
Q. Cal. Linear		
P. Filter		6
Q. Filter		6
P. Full Scale		160 Bar
Q. Full Scale		250 L/m
Sys Stats: Ready (Tech.)		P: 0.0
S: 0	T: 0	R: 2100

If the state of linear pressure calibration failed, the operator will need to calibrate again until succeed.

LED panel commissioning setup parameter:

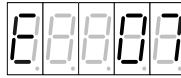

The calibration of full range is the same with zero position calibration mode: change the pressure reference of upper PC to full range pressure value, and change the pressure calibration point to "full range", then adjust the pressure of injection molding machine to the corresponding pressure of full range, finally, calibrate and confirm.

LED panel commissioning setup parameter:

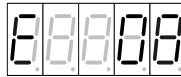

c) Polyline calibration



The polyline calibration mode is the same with linear calibration; the operator can deem the polyline calibration as the composition of multi-step linear calibration.

Set the "pressure calibration mode" to "polyline calibration" via setup mode of function parameters.

Monito	Setting	Tuning
Drive Type		CT-7501-A-0
Motor Type		U1004F.15.3
Pump Type		SETTIMA 28mL/r
P. Sensor Zero		
P. Cal. Mode		Nonlinear
Q. Cal. Mode		Linear
Sys Stats: Ready (Tech.)	P:	0.0
S: 0	T: 0	R: 2100

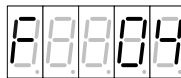



LED panel commissioning setup parameter:





Stop the highlighted cursor at the polyline pressure calibration via  and  key, then press  key to enter polyline pressure calibration point selection interface.

Monito	Setting	Tuning
P. Cal. nonlinear		
Q. Cal. Linear		
P. Filter		6
Q. Filter		6
P. Full Scale		160 Bar
Q. Full Scale		250 L/m
Sys Stats: Ready (Tech.)		P: 0.0
S: 0	T: 0	R: 2100

Adjust the pressure reference of injection molding machine to 0bar before performing below operations.

Stop the cursor at polyline pressure calibration point selection via  and  key, and adjust the item name to "00" (namely "0bar" pressure reference) via  and  key.

Stop the highlighted cursor at "save" via  and  key.

Parameter Settings		
P. Cal. nonlinear		
P. Analog Input	3.72 V	0.327 A
Nonlinear 00	0%	0Bar
Save	Cancel	
Sys Stats: Ready (Tech.)		P: 0.0
S: 0 rpm	T: 0 Nm	R: 2100

Press  to return to setup mode menu, if the state column of polyline pressure calibration displays "succeed", and then disappears, it means the calibration is succeeded.

Monito	Setting	Tuning
P. Cal. nonlinear		Succeed
Q. Cal. Linear		
P. Filter		6
Q. Filter		6
P. Full Scale		160 Bar
Q. Full Scale		250 L/m
Sys Stats: Ready (Tech.)		P: 0.0
S: 0	T: 0	R: 2100

If the state of polyline pressure calibration is "failed", the operator needs to calibrate again until succeeded.

LED panel commissioning calibration setup parameter:

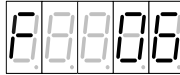

The calibration mode of other calibration points is the same with 0bar point calibration (refer to the table below), adjust the upper PC to the corresponding pressure reference value.

No.	Calibration quantity (relation with full range)
0	0%
1	5%
2	10%
3	20%
4	30%
5	40%
6	50%
7	60%
8	70%
9	80%
10	90%
11	95%
12	100%

9.2.8 Flow Calibration

The calibration for “single pump”, “composite”, “multi-mode” and “multi-pump” differs from each other slightly:

- Single pump type: Calibrate directly regardless of “network enable” [P00] parameter.
- Composite and multi-mode type;

First, disable the “network enable” [P00] under “multi-pump” menu, then calibrate each node according to the calibration mode of single pump system.

- Multi-pump type:

The “max flow” of each node has been set properly during 9.2.8 pressure calibration, the max system flow equals to the sum of the max flow of each node. Users do not need to set “max flow” during flow calibration.

Modify “operation enable” [H00] item to “disable” state, (in multi-pump type, change the “drive enable” item to “disable” state)

1) Filter adjustment [F09]

The method is the same with 9.2.8(1)

2) Calibration

- a) Set the max flow and flow full range [F13][F11]

The method is the same with 9.2.8(2)(a)

- b) Linear calibration zero position calibration[E09], full range calibration[E10]
The method is the same with 9.2.8(2)(b)
- c) Polyline calibration [F07]
The method is the same with 9.2.8(2)(c)

3) Parameter programming

For above parameter setup, parameter programming must be executed before the drive is powered off, otherwise the drive will maintain the original parameter. The parameter programming mode is executed based on 9.2.5.

9.2.9 Pressure-hold Test

1) Pressure-hold test in low pressure

Adjust the overflow pressure of the overflow valve to the max value before performing below operations.

Under commissioning mode, when the control mode is “process mode”, stop the highlighted cursor at “process command mode” via ▲ and ▼ key, and press 确认 to enter setup interface.

Monitor	Setting	Tuning ▶
Speed given		0 r/m
Process	Analog input	
instruction mode		0.0 L/m
Q. Command		0.0 Bar
P. Command		
Sys Stats: Ready (Tech.) P: 0.0Bar		
S: 0 rpm T: 0 Nm R: 2100		

Change the name of process command mode to “communication input” via ▲ and ▼ key.

Stop the highlighted cursor at “save” via ◀ and ▶ key, then press confirm key to return to commissioning menu column, and users can read that the “process command mode” has been changed to “communication mode”.

Parameter Settings		
Process instruction mode		
Communications input		
Save	Cancel	
Sys Stats: Ready (Tech.) P: 0.0		
S: 0 rpm T: 0 Nm R: 2100		

LED panel commissioning setup parameter:

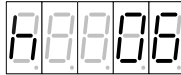

Adjust “flow reference” [H07] to 10L/m; adjust “pressure reference” [H08] to 20bar and adjust “operation enable” [H00] item to “enable” state.

Check whether oil circuit leakage occurred, and whether the pressure feedback value [d09] in HMI and the pressure gauge of injection molding machine is 20bar.

2) Pressure-hold test in high pressure

After pressure-hold test in low pressure is passed, users can carry out pressure-hold test in high pressure. When “operation enable”[H00] is in “enable” state, the “flow reference” [H07] is based on the 80% of the max flow of the injection molding machine system, “pressure reference” [H08] rises gradually to the max pressure needed by the injection molding machine, observe the system actual pressure [d09] and motor speed[d07].

If the actual system pressure cannot reach the set pressure, users need to check whether abnormal leakage occurred to the hydraulic pressure oil circuit.

If the actual system pressure reaches the set pressure but the average motor speed is higher than the value recommended in the table, users will need to figure out the leakage cause:

Situation 1: Abnormal leakage occurred to the oil pump;

Situation 2: Abnormal leakage occurred to the hydraulic pressure oil circuit;

Situation 3: Leakage occurred to the overflow valve.

Measurement Definition	Pass The Standard (Recommended Value)
Motor speed during pressure-hold (pressure reference 100%FS, pressure-hold time is 5s)	60-100rpm (plunger pump) <150rpm (screw pump) <300rpm (gear pump)

After confirming the pressure and motor speed during pressure-hold fulfill requirements, check according to the data in the table whether the pressure fluctuation comply with system requirements .

Measurement Definition	Pass The Standard (Recommended Value)
Pressure fluctuation (pressure reference 100%FS, pressure-hold time is 5s)	≤3bar (plunger pump) ≤2bar (screw pump) ≤3bar (gear pump)

9.2.10 Calibration of Overflow Valve

When “operation enable”[H00] is in “enable” state, “flow reference” [H07] is set to 30% of the max flow of injection molding machine system, “pressure reference” [H08] is overflow valve protection pressure used to adjust the overflow pressure of overflow valve. When the actual pressure is larger than the overflow valve protection pressure, confirm the overflow valve can be opened for discharge.

9.2.11 Calibration Review

Set the “pressure reference” [H08] of upper PC to 2bar, 10bar, 50bar, 100 bar, full range pressure -2bar and full range pressure respectively. Observe whether the read-out of pressure gauge complies with the setting, and if not, perform pressure calibration again.

Set the “flow reference” [H08] of upper PC to 2%, 50%, 98% and 100% respectively, and observe if the motor speed during operating is in proportion to the hydraulic pressure oil flow of the injection molding machine (measure by the hydraulic pressure motor speed or injection cylinder speed), if not, perform flow calibration again.

9.2.12 Automatic Operation and System Performance Adjustment

1) System restart

After switching off the system power, repower-on and the drive uses IO enable signal to turn on the operation enable, carry out reverse operation based on the disable mode specified in 9.2.1(3).

Restart system power and after confirming the servo system is in working state, handover the control right to the injection molding machine drive to control the servo system operation according to the injection molding machine parameters.

2) Servo performance adjustment

Servo system process control includes the following gain parameters, by which users can adjust the response features and stability precision of the servo system.

Set during single pump or shunt application:

Pressure proportional gain 0-3, [E17] [F22] [F25] [F28]

Pressure integral gain 0-3, [E18] [F23] [F26] [F29]

Set during converging application:

Multi-pump pressure proportional gain 0-3: [P09] [P12] [P15] [P18]

Multi-pump pressure integral gain 0-3: [P10] [P13] [P16] [P19]

Speed proportional gain, [E19]

Speed integral gain, [E20]

When finishing motor and pump model selection, the drive has selected the matching value of the motor and pump. If the system performance indicator cannot reach customer requirements, fine tune above parameter values until the requirements are fulfilled.

Chapter 10 Alarm and Solution

10.1 Protection Display List

The servo drive carries multiple alarms and protection function including overvoltage and overcurrent. Once abnormal fault occur, the protection function acts, servo drive stops output and motor stops running. Users can cope with faults according to the contents displayed by the servo drive while referring to fault causes and solutions. The fault records will be stored in the memory of the servo drive, which can record the latest five abnormal alarms and the time of occurrence, which can be checked by users via digital LED operation panel or HMI communication.

Code	Protection Item	Meaning	Code	Protection Item	Meaning
Err01	IPM fault	Short-circuit current passes power module transiently	Err02	Overcurrent	Output current exceeds the allowed operating current of the drive
Err03	DC overvoltage	Main circuit DC voltage is abnormally high	Err04	DC undervoltage	When motor is powered on for operation, the main circuit DC voltage drops below the protection value
Err05	FWD overspeed	The FWD speed of servo motor is abnormally high	Err06	Module over-temperature	The cooling fin of the servo drive is too hot
Err07	Motor over-temperature	Servo motor winding is too hot	Err08	Software fault	Servo drive software operates abnormally
Err09	CAN fault	When process command is CAN continuous or multi-pump parallel application, CAN communication is abnormal and the drive reports this fault	Err10	Environment over-temperature	The air temperature inside the drive is too high
Err11	Self-inspection fault	Internal hardware of the drive is abnormal	Err12	Task re-entry	Software program calling error
Err13	Over-pressure of oil pressure	The pressure of oil pressure system exceeds the allowed value	Err14	REV overspeed	During process control mode, overspeed occurred to motor reverse rotation
Err15	Pressure sensor fault	Pressure sensor is wired improperly or	Err16	Brake resistor is damaged	Brake resistor is not connected or damaged

Code	Protection Item	Meaning	Code	Protection Item	Meaning
		damaged			
Err17	AC overvoltage	Input AC voltage is too high	Err18	EEPROM fault	Servo unit EEPROM data abnormal
Err19	Enable undervoltage	When the motor starts to power on, the main circuit DC voltage is too low	Err20	AC undervoltage	Input AC voltage is too low
Err21	Brake overload	Brake resistor overload and cause overheating	Err22	Node fault	During multi-pump parallel application, the slave node is faulty, main drive will report this fault
Err23	Rectification unit fault	The detection value of AC voltage and DC voltage does not match	Err24	Power-on overtime	Power-on relay closing overtime
Err25	485 communication fault	When process command mode is 485 continuous, 485 communication is abnormal and the drive reports this fault	Err26	Current feedback channel fault	Current zero drift is too large
Err27	Incremental encoder zeroing interruption fault	Encoder zeroing detection is interrupted	Err28	Incremental encoder zeroing overtime fault	Encoder zeroing detection is overtime
Err29	Incremental encoder zeroing operation fault	Incremental encoder zeroing operation fault	Err30	Motor initial angle test interruption fault	Static test on motor D axis initial angle is interrupted
Err31	Resolver fault	Resolver line is not connected or resolver plate is faulty	Err33	Resolver sampling fluctuation fault	Resolver sampling value fluctuates violently
Err34	A phase current sampling fluctuation is too large	A phase current sampling fluctuation is too large	Err35	B phase current sampling fluctuation is too large	B phase current sampling fluctuation is too large

Code	Protection Item	Meaning	Code	Protection Item	Meaning
Err36	A phase current sampling zero drift is too large	A phase current sampling zero drift is too large	Err37	B phase current sampling zero drift is too large	B phase current sampling zero drift is too large
Err38	DC voltage sampling fluctuation is too large	DC voltage sampling fluctuation is too large	Err39	Pressure feedback sampling fluctuation is too large	Pressure feedback sampling fluctuation is too large
Err40	Pressure feedback sampling zero drift is too large	Pressure feedback sampling zero drift is too large	Err41	Pressure reference sampling fluctuation is too large	Pressure reference sampling fluctuation is too large
Err42	Flow reference sampling fluctuation is too large	Flow reference sampling fluctuation is too large	Err43	Ambient temperature sampling fluctuation is too large	Ambient temperature sampling fluctuation is too large
Err44	Module temperature sampling fluctuation is too large	Module temperature sampling fluctuation is too large	Err45	Motor temperature sampling fluctuation is too large	Motor temperature sampling fluctuation is too large
Err49	Encoder initial angle test fault	Encoder initial angle test current does not follow, overtime, etc.	Err50	Phase sequence test fault	Motor pole pairs is calculated wrong, speed limit value is invalid, current does not follow, overtime
Err51	Motor resistor test fault	Current does not follow, overtime, resistor test value is invalid	Err52	Motor parameter dynamic test fault	Large speed error, current does not follow, large load, overtime, test value is invalid
Err53	Motor parameter static test fault	The calculation result of motor parameter is invalid	Err54	Diagnosis interruption fault	If fault occurred during executing diagnosis action, the drive will stop diagnosis and display Err54 fault

10.2 Analysis on Fault Source

As shown below, the electro-hydraulic servo system of KINWAY injection molding machine is mainly comprised of permanent magnet synchronous motor, motor rotor position/speed sensor (resolver), servo drive, the oil pump which is coaxially connected to the servo motor and the pressure sensor used to detect system oil pressure.

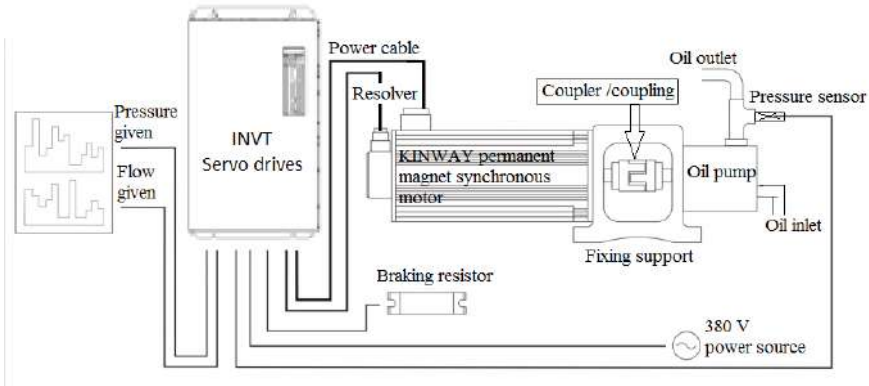

Strictly speaking, all the parts displayed in above figure (connection cables included) can be deemed as the fault source. The figure below shows the layout of system fault:

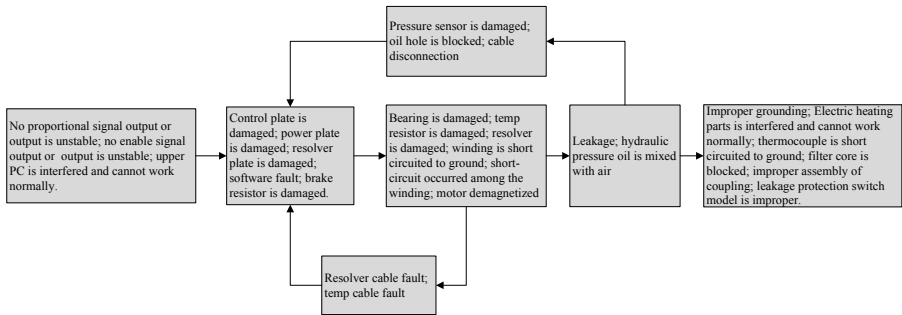

The fault layout aims to assist users in analyzing the system in a comprehensive manner to figure out the fault source quickly and accurately.

10.3 Protection Causes and Solutions

If alarm code fault occurred, the panel will display the fault code which can be handled as shown below. If the problem persists, contact the distributor or the service department of our company.

The first group of fault:

Fault Code	Protection Item	Cause	Solution
Err01	IPM fault	U, V and W is connected to the ground wire in a wrong way	Check the wiring and connect correctly
		The U, V and W used by the motor main circuit is short circuited with the ground wire	Correct or replace the cable used by motor main circuit
		Regenerative resistor is wired improperly	Check the wiring and connect correctly
		Servo drive fault (current feedback circuit, power transistor or circuit plate fault)	Replace the drive
		The U, V and W of the servo motor is short circuited with the ground wire	Replace the servo motor
		The U, V and W of servo motor is short circuited with each other	
		Drive parameters are set wrong	Reset parameters
		The servo drive is installed in an improper way (direction and the in-between intervals are improper or affected by peripheral heating devices)	Lower the ambient temperature of the servo unit to below 45°C

The second group of faults

Fault Code	Protection Item	Cause	Solution
Err02	Overcurrent	Motor wiring is abnormal (improper wiring or connection)	Correct motor wiring
		Position sensor wiring is abnormal (improper wiring or connection)	Correct position sensor wiring
		Servo drive fault	Replace the servo drive
Err03 Err17	DC overvoltage AC overvoltage	AC power voltage is too high	Adjust the AC power voltage to normal range
		Check AC power voltage (whether there is large voltage variation)	
		The speed is too high, load rotation inertia is too large (regenerative brake capacity is insufficient)	Re-discuss load conditions and operation conditions
		Servo drive fault	Replace the servo drive

The third group of fault:

Fault Code	Protection Item	Cause	Solution
Err04 Err20	DC undervoltage AC undervoltage	AC power voltage is low (whether there is large voltage drop)	Adjust the AC power voltage to the normal range

Fault Code	Protection Item	Cause	Solution
Err19	Enable undervoltage	Transient power off occurred	Restart running via reset
		The cable used by motor main circuit is short circuited	Correct or replace the cable used by motor main circuit
		Servo drive fault	Replace the servo drive
Err23	Rectification unit fault	AC voltage and DC voltage detection is erroneous	Re-calibrate DC voltage or AC voltage
		Rectification unit problem	Replace rectification drive plate or the drive
Err05 Err14	FWD overspeed; REV overspeed	The U, V and W phase sequence of motor wiring is wrong	Correct motor wiring
		Position sensor wiring is wrong	Correct position sensor wiring
		Mal-operation occurred to position sensor due to interference	Take anti-interference measures
		Servo drive circuit plate fault	Replace the servo drive
Err06 Err07 Err10	Module over-temperature; Motor over-temperature; Environment over-temperature	The load exceeds rated load	Re-discuss load condition, operation condition or motor capacity
		The ambient temperature of servo system exceeds 55°C	Lower the ambient temperature of the servo unit to below 55°C
		Servo motor temperature sensor is wired wrong	Correct motor temperature sensor wiring
		Servo drive fault	Replace servo drive

The fourth group of fault

Fault Code	Protection Item	Cause	Solution
Err08	Program run out fault	Interfered by static electricity lightning stroke	Reset and run again
Err11	Self-inspection fault	Motor position sensor is abnormal	Replace the motor
		Servo drive fault	Replace the servo drive
Err12	Software fault	Servo drive fault	Replace the servo drive
Err13	Overpressure of oil pressure	Pressure sensor is wired wrong	Correct pressure sensor wiring
		Pressure sensor is abnormal	Replace pressure sensor
		Commissioning of oil pump control and speed control parameters is improper	Adjust the control parameters to a proper value

The fifth group of fault:

Fault Code	Protection Item	Cause	Solution
Err15	Pressure sensor fault	Pressure sensor wiring is wrong	Correct pressure sensor wiring
		Pressure sensor is abnormal	Replace pressure sensor
		Servo drive fault	Replace the servo drive
Err16	Brake resistor is damaged	The rotary energy when PB stops exceeds the capacity of DB resistor	Re-select the capacity of regenerative resistor or re-discuss load conditions
		Check whether regenerative resistor is wired improperly, disconnected or broke	Correct the wiring of external regenerative resistor
		Servo drive fault (regenerative transistor, voltage detection fault)	Replace the servo drive
Err18	EEPROM is damaged	Power is off during parameter setting	Re-enter parameters after restoring to default values
		Power is off during writing fault code	
		Servo drive EEPROM and peripheral circuit fault	Replace the servo drive
Err21	Brake resistor overload	The motor is in power generation state or starts/stops frequently in a long time	Adjust the motor running condition or replace with a power brake resistor which carries larger power
Err26	Current feedback channel fault	Interference is large	Eliminate the interference
		Current sensor is damaged	
Err31	Resolver fault	Resolver is not connected or poorly contacted	Detect the resolver wire and resolver plate
		Resolver plate fault	

The sixth group of fault

Fault Code	Protection Item	Cause	Solution
Err33	Resolver sampling fluctuation fault	Interference or resolver plate is damaged	Eliminate the interference and replace the resolver plate
Err34	A phase current sampling fluctuation is too large	Interference	Eliminate interference, current sensor, replace control plate
		Current sensor is damaged	
		Control plate is damaged	
Err35	B phase current sampling fluctuation is too large	Interference	Eliminate interference, current sensor, replace control plate
		Current sensor is damaged	
		Control plate is damaged	
Err36	A phase current	The same with above	The same with above

Fault Code	Protection Item	Cause	Solution
	sampling zero drift is too large		
Err37	B phase current sampling zero drift is too large	The same with above	The same with above
Err38	DC voltage sampling fluctuation is too large	Interference	Eliminate interference, replace the control plate
		Control plate is damaged	
Err39	Pressure feedback sampling fluctuation is too large	Interference	Eliminate interference, replace pressure sensor and control plate
		Pressure sensor is damaged	
		Control plate is damaged	
Err40	Pressure feedback sampling zero drift is too large	Interference	Eliminate interference, replace pressure sensor and control plate, system pressure discharge
		Pressure sensor is damaged	
		Control plate is damaged	
		System has pressure	
Err41	Pressure reference sampling fluctuation is too large	Interference	Eliminate interference, detect the analog signal reference of upper PC, replace the control plate
		Analog signal reference of upper PC fluctuates violently	
		Control plate is damaged	
Err42	Flow reference sampling fluctuation is too large	The same with above	The same with above
Err43	Ambient temperature sampling fluctuation is too large	Interference	Eliminate interference, replace the control plate
		Control plate is damaged	
Err44	Module temperature sampling fluctuation is too large	The same with above	The same with above
Err45	Motor temperature sampling fluctuation is too large	The same with above	The same with above

The seventh group of fault

Fault Code	Protection Item	Cause	Solution
Err49	Encoder initial angle test fault	Current sensor is damaged	Detect the drive, connect the motor
		Motor is not connected	
Err50	Phase sequence test fault	Current sensor is damaged	Re-enter motor nameplate parameters, detect the drive, connect the motor
		Motor nameplate parameter input is erroneous	

Fault Code	Protection Item	Cause	Solution
		Motor is not connected	
Err51	Motor resistor test fault	Current sensor is damaged	Detect the drive, connect the motor
		Motor is not connected	
Err52	Motor parameter dynamic test fault	Current sensor is damaged	Detect the drive, re-enter motor nameplate parameter, apply no-load or light-load on the motor
		Positions sensor fault	
		Load is too large	
		Parameter value is invalid	
Err53	Motor parameter static test fault	Parameter value is invalid	Re-enter motor nameplate parameters

10.4 Fault Rule-Out Flowchart

Err01: IPM fault

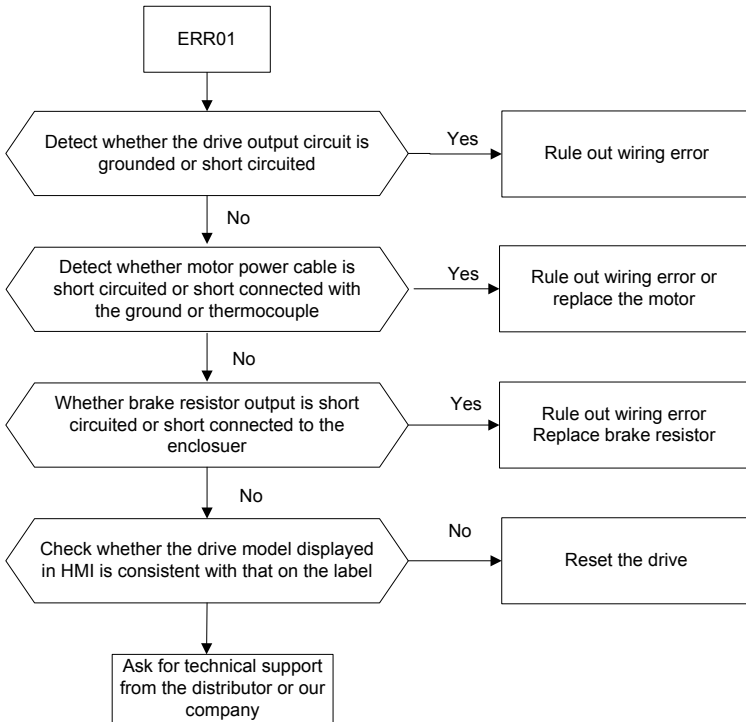

Err02: Overcurrent

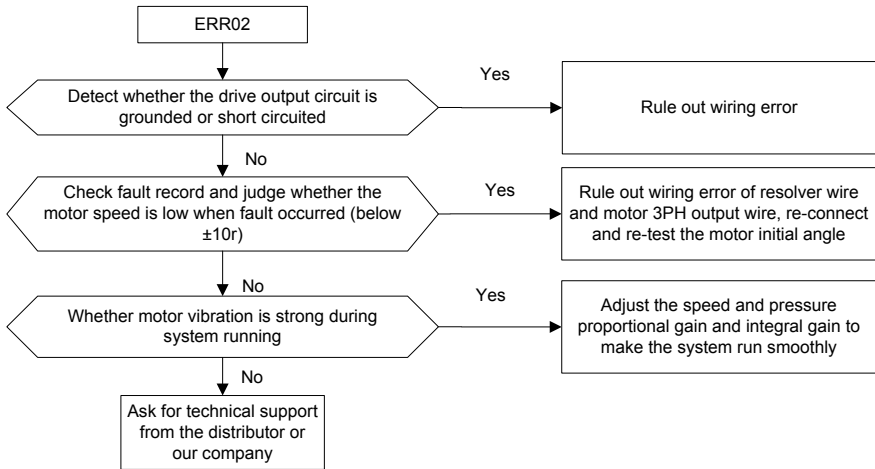

Err03: DC overvoltage

Err17: AC overvoltage

Err23: Rectification unit fault

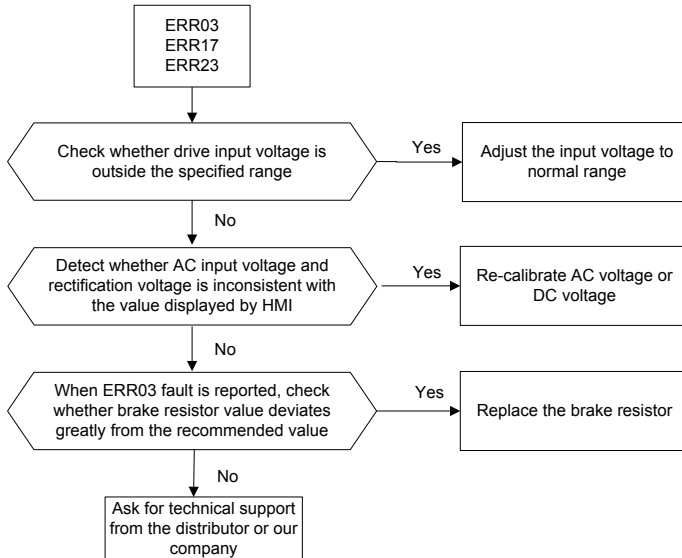

Err04: DC undervoltage

Err19: Enable undervoltage

Err20: AC undervoltage

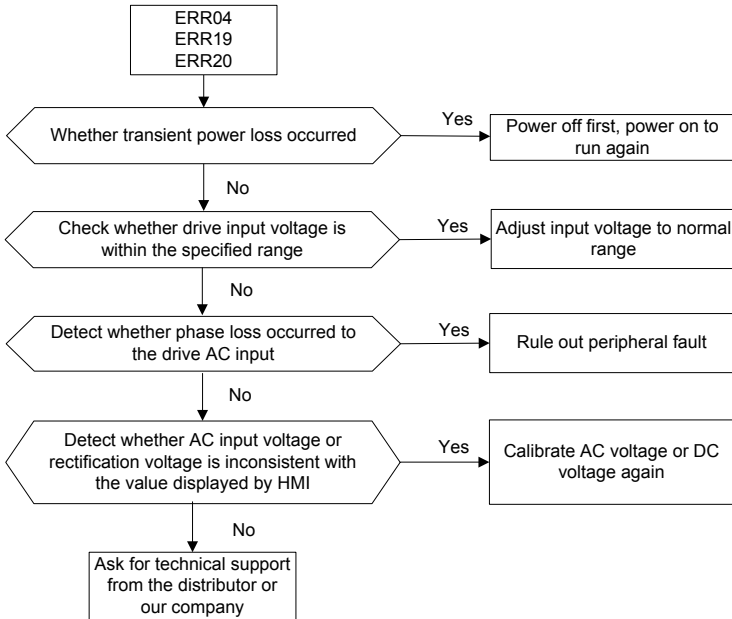

Err05: FWD overspeed

Err14: REV overspeed

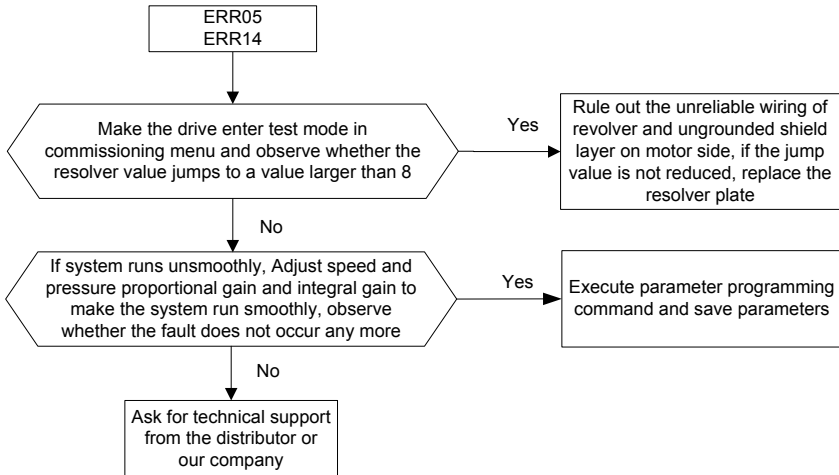

Err06: Module over-temperature

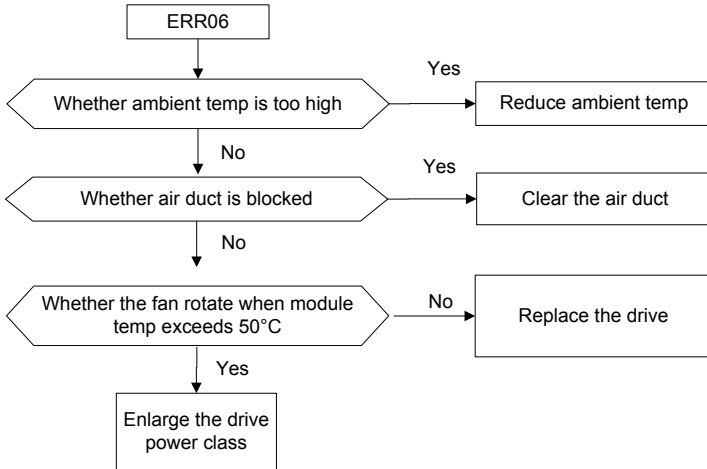

Err07: Motor over-temperature

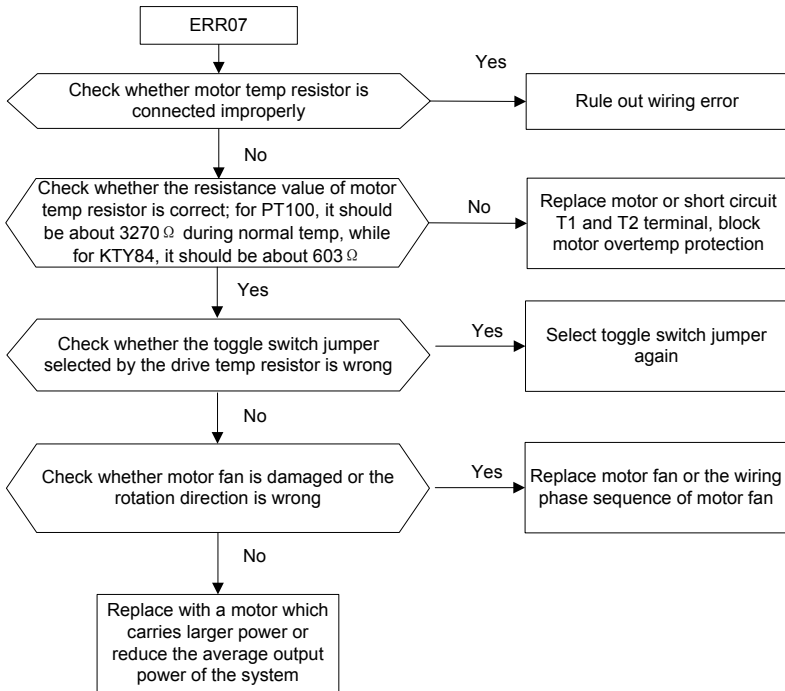

Err08: Software fault

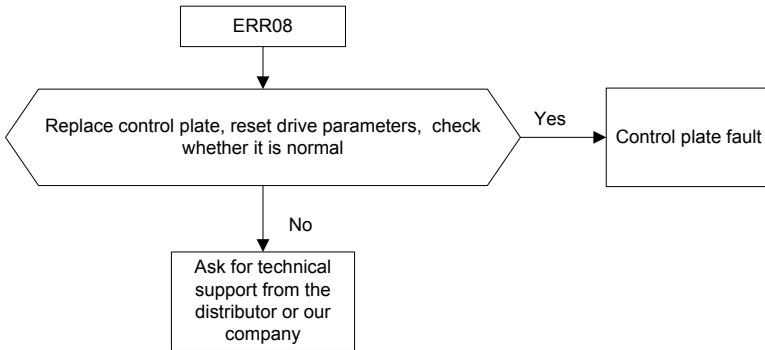

Err09: CAN fault

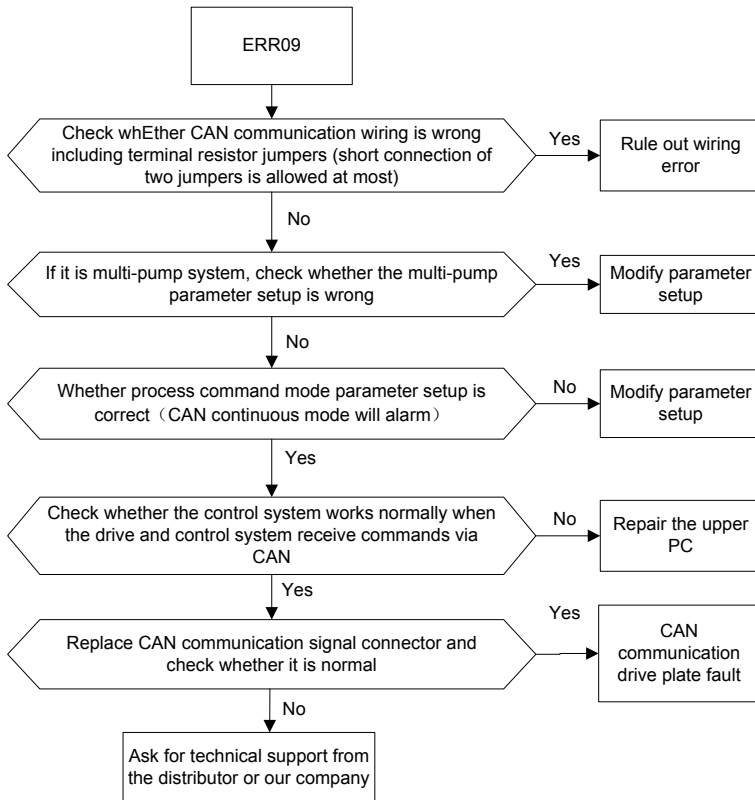

Err10: Environment over-temperature

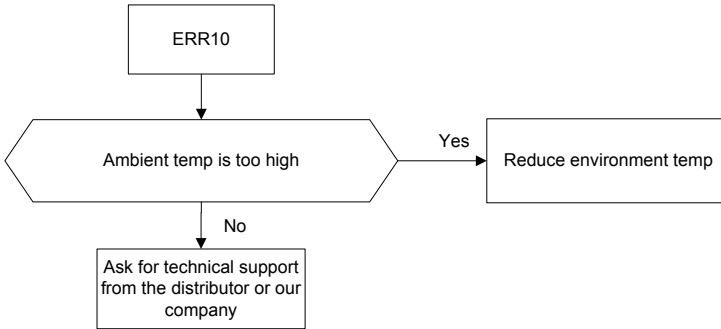

Err11: Self-inspection fault

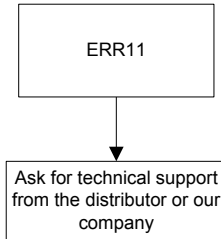

Err12: Task re-entry

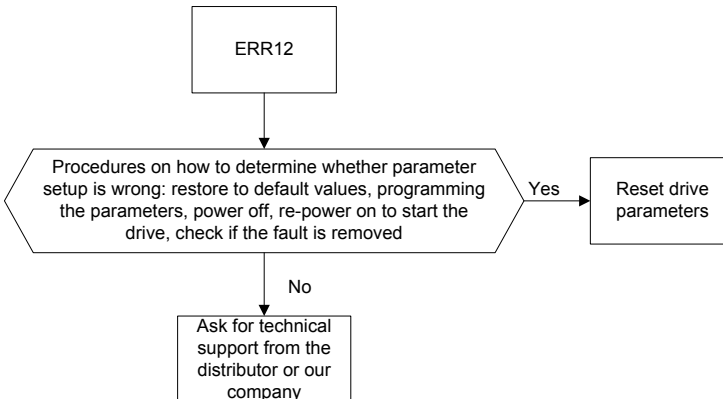

Err13: Over-pressure of oil pressure

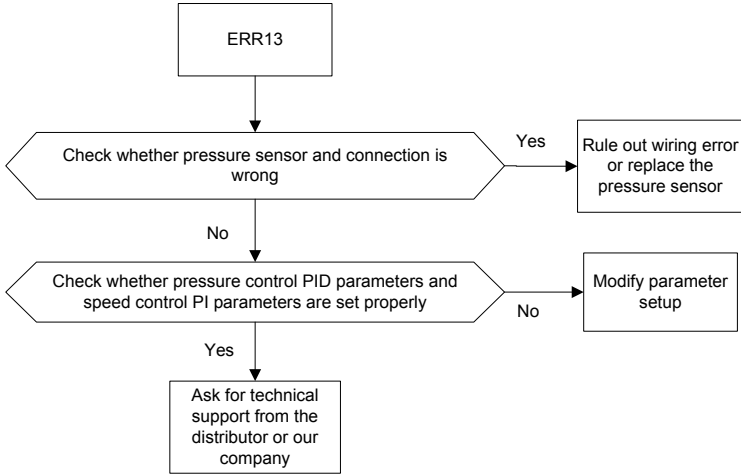

Err15: Pressure sensor fault

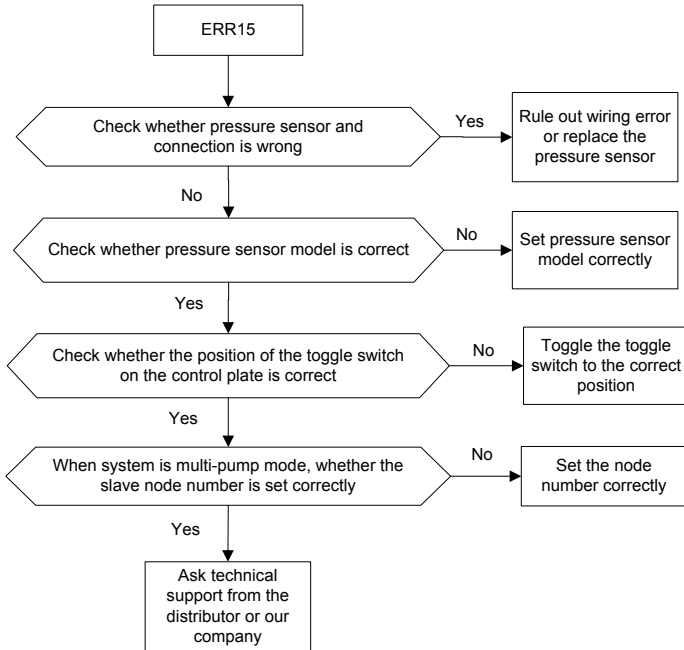

Err16: Brake resistor is damaged

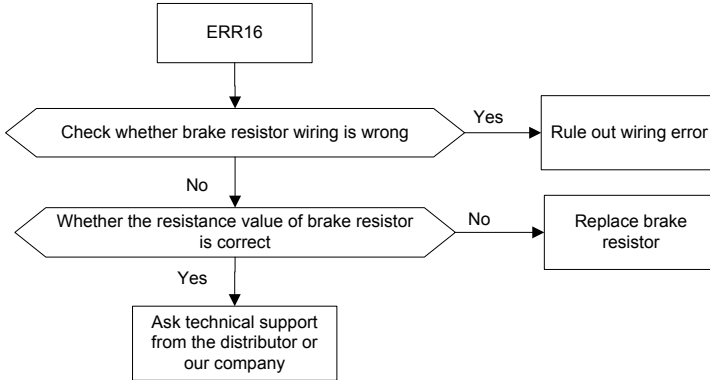

Err18: EEPROM fault

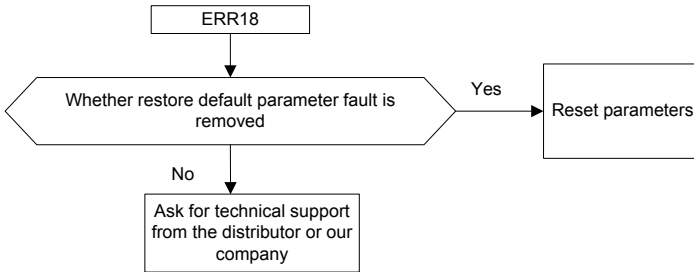

Err21: Brake overload

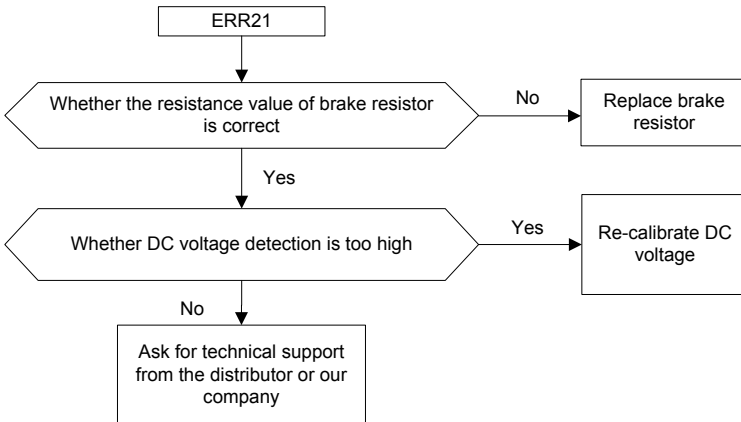

Err22: Node fault

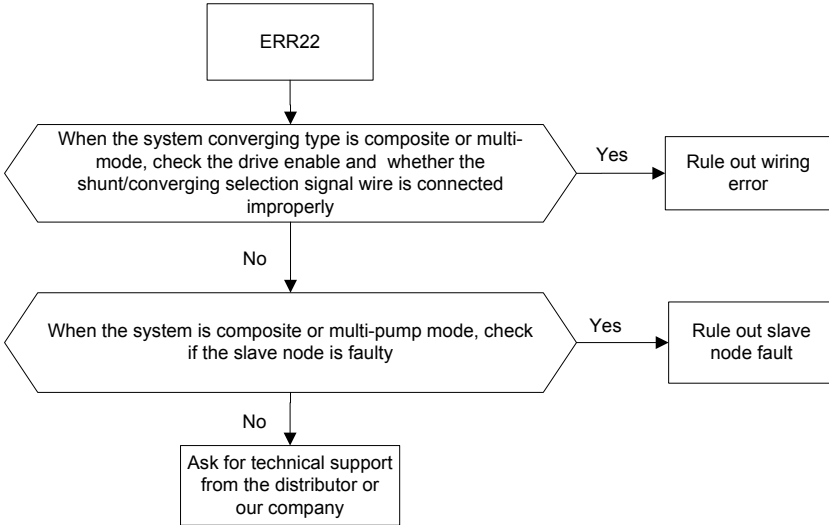

Err24: Power-on overtime

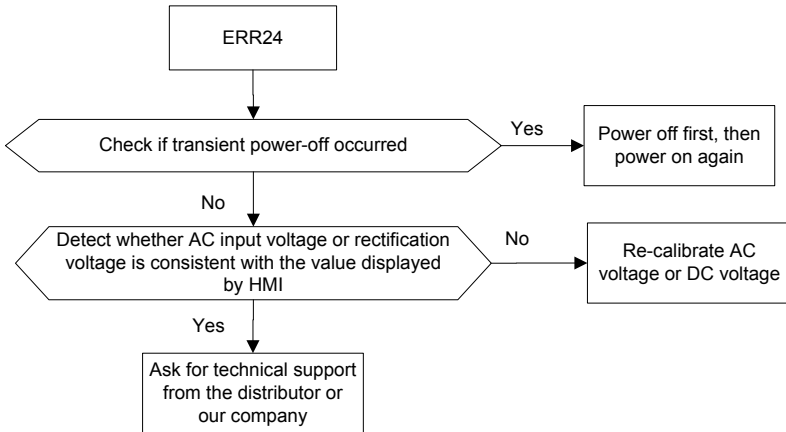

Err25: 485 communication fault

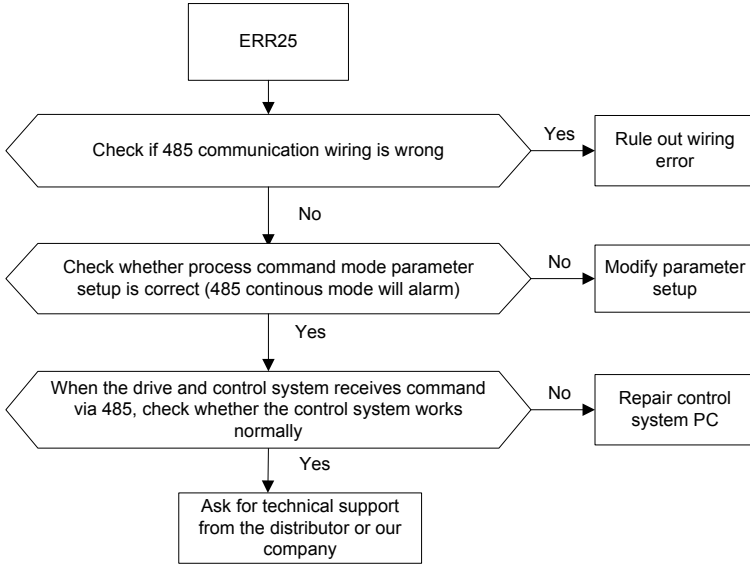

Err26: Current feedback channel fault

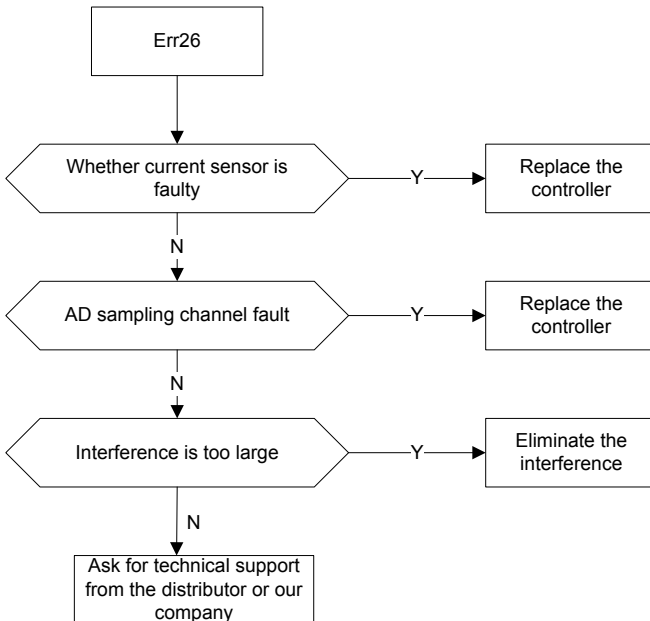

Err31: Resolver fault

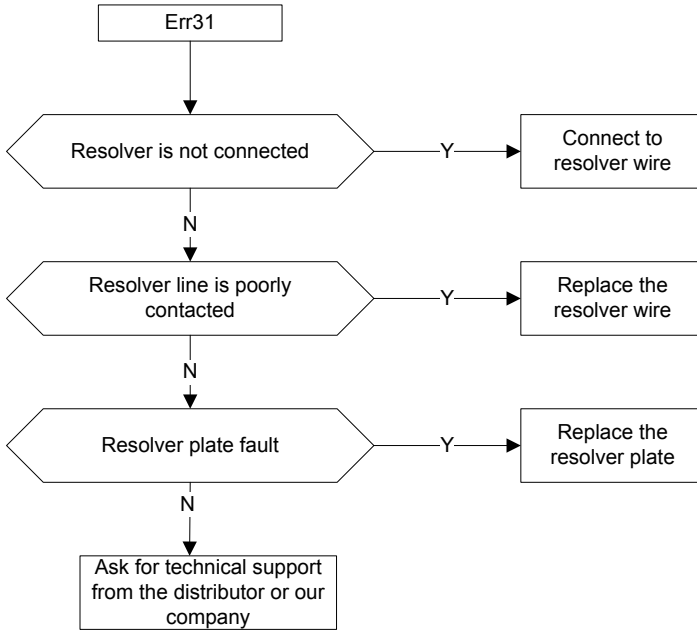

Err33: Resolver sampling fluctuation is too large

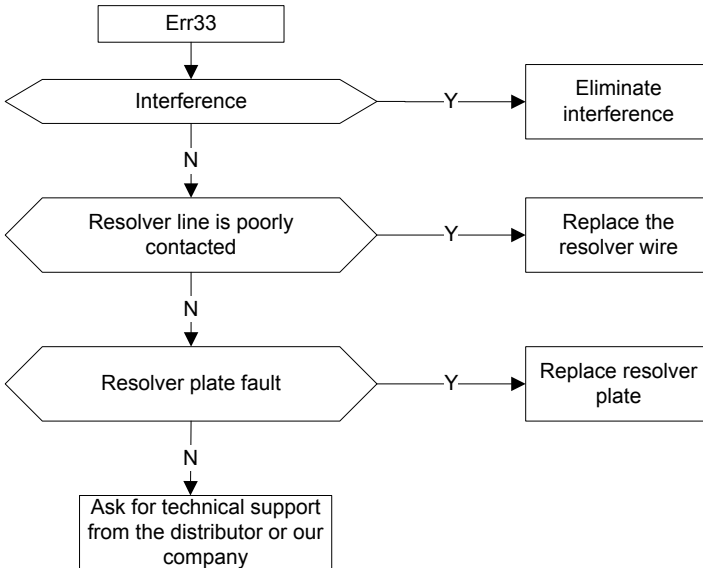

Err34: A phase current sampling fluctuation is too large

Err35: B phase current sampling fluctuation is too large

Err36: A phase current sampling zero drift is too large

Err37: B phase current sampling fluctuation is too large

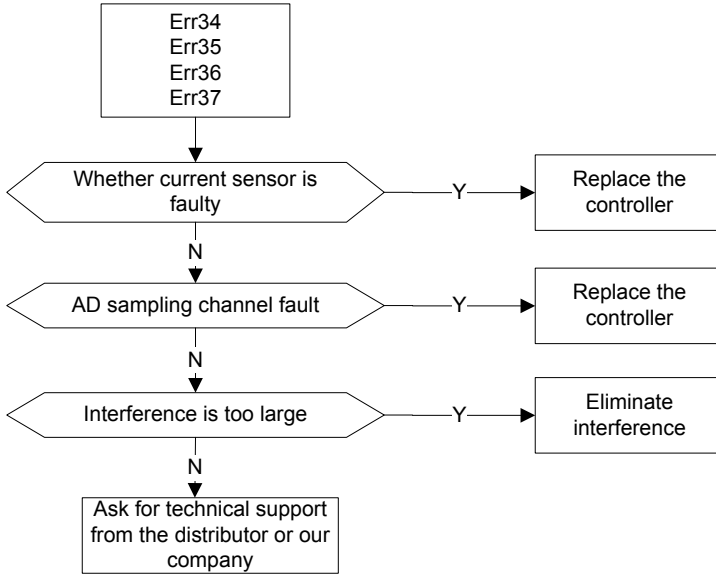

Err38: DC voltage sampling fluctuation is too large

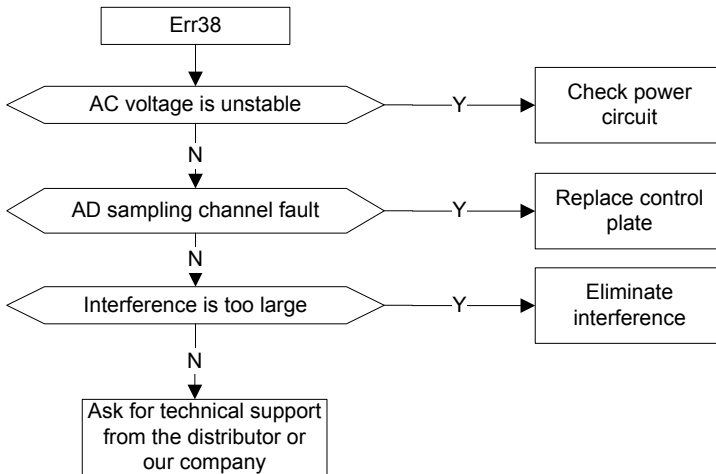

Err39: Pressure feedback sampling fluctuation is too large

Err40: Pressure feedback sampling zero drift is too large

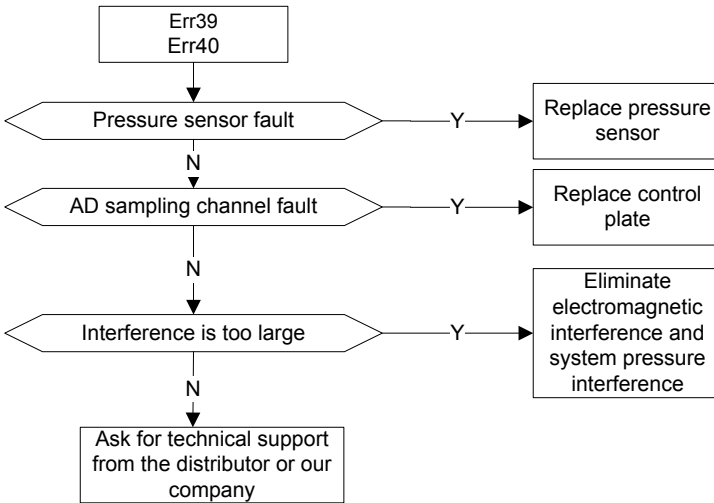

Err41: Flow reference sampling fluctuation is too large

Err42: Pressure reference sampling fluctuation is too large

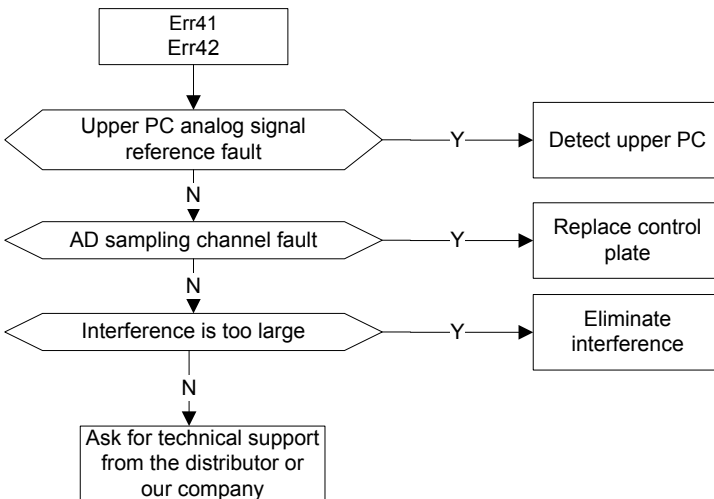

Err43: Environment temperature sampling fluctuation is too large

Err44: Module temperature sampling fluctuation is too large

Err45: Motor temperature sampling fluctuation is too large

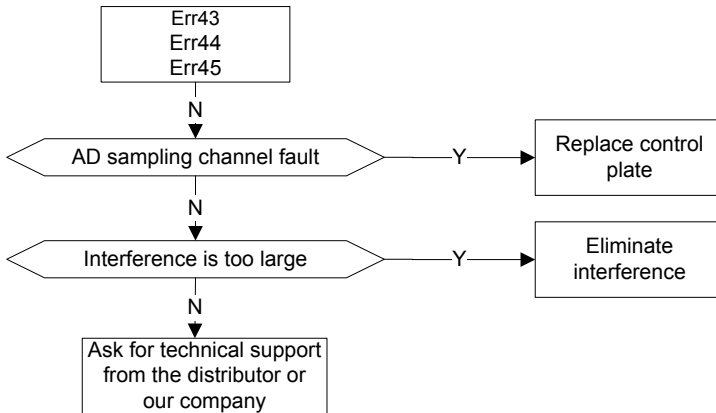

Err49: Encoder initial angle test fault

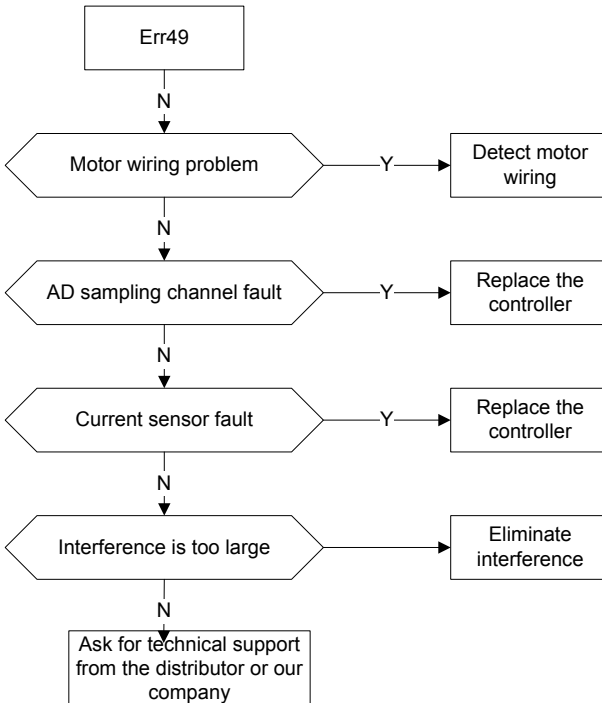

Err50: Phase sequence detection fault

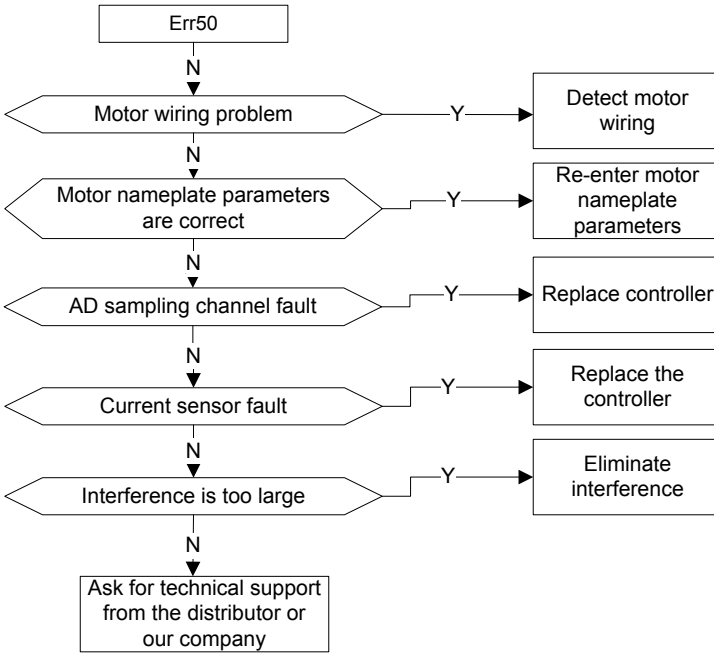

Err51: Motor resistor test fault

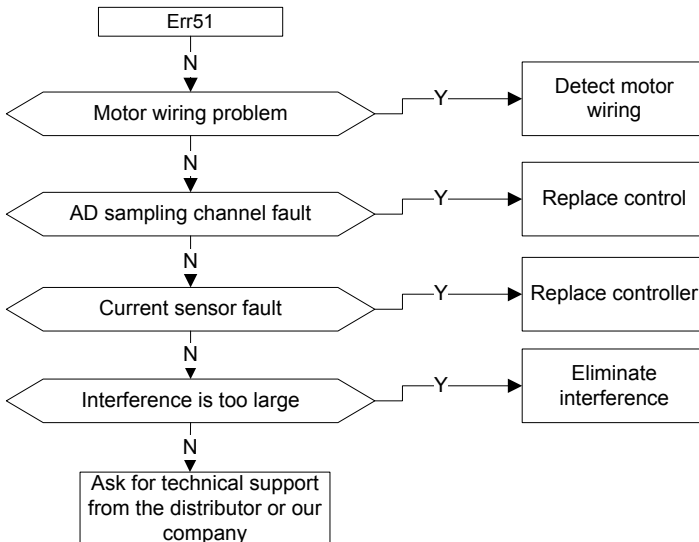

Err52: Motor parameter dynamic test fault

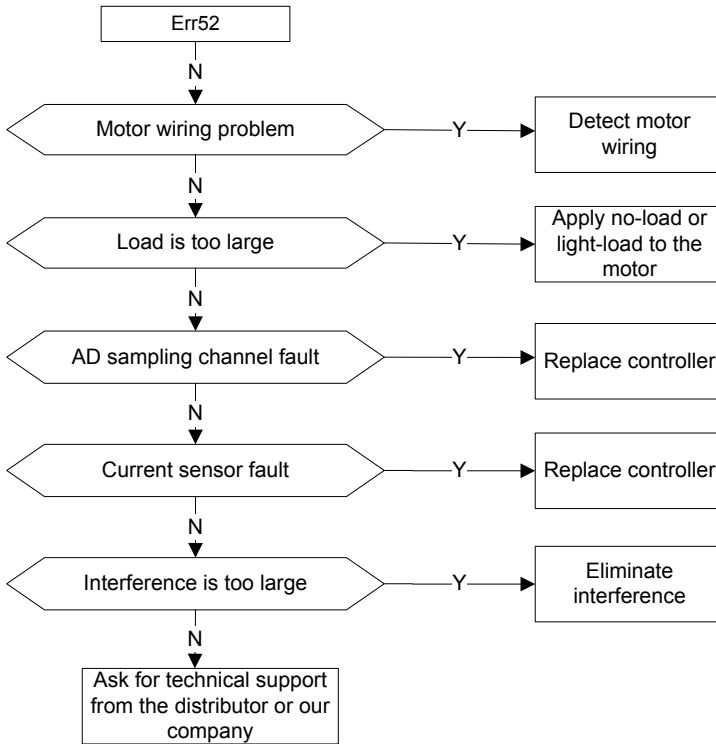

Err53: Motor parameter static test fault

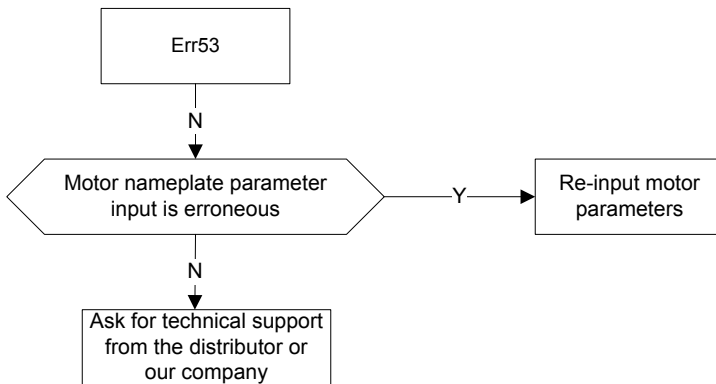

Chapter 11 Maintenance and Inspection

To avoid the danger of electric shock, only the maintenance staff who have received professional training are allowed to touch the internal circuit parts. Proper maintenance and periodic inspection is required for keeping the serve electro-hydraulic control system of injection molding machine in a good state in a long term.

11.1 Precautions

After cutting off all the power supplies, the capacitors inside the drive may still carry high voltage electricity during a period of time; therefore, after electric discharge, it is a must to measure with multimeter the voltage of U+ and U- terminals to ensure they are below 36V.

11.2 Inspection Items

The items to be inspected periodically are listed below:

Item	Description	Method And Instruments	Criterion
Ambient environment	Ambient temperature, humidity, dust level, dust component, oil and acid and alkaline fog, etc.	Visual examination, thermometer and hygrometer	Fulfill the requirements specified in the operation manual
Power voltage	Whether the voltage of power supply is normal	Voltmeter, multi-meter	Fulfill the requirements specified in the operation manual
	Whether power-on logic action (contactor, air switch, etc.) is normal		
Cosmetic and parts inspection	Whether there is abnormal vibration, noise, deformation and damage	Screw up the screws;	Abnormal
	Whether external brake resistor connection is loosened, resistor is aged, or resistance value is normal	Visual inspection; Multimeter	
Circuit inspection	No abnormal odor	Smell, listen and observe	Normal
	Whether cooling fan rotates normally		
	Whether connectors are loosened		
	Whether the lead wires are damaged		
	Whether filter capacitors are deformed or there is leakage liquid		

11.3 Tramegger Test

The tramegger test can be used to test the insulation between motor winding and the enclosure only, and it must be ensured that all the connections between the motor and servo drive have been disconnected before test. 1000V tramegger should be adopted for test and the insulation resistor should be larger than 50MΩ.

Improper insulation test method may damage the servo drive, users should not perform insulation test by themselves.

11.4 Replacement of the Parts

The service life of the bearing of cooling fan is about 30,000h, which can sustain about 3 – 4 years during continuous usage. If abnormal noise and vibration occurred to the fan, a replacement will be required.

Service life of the aluminum electrolytic capacitor used for filter will be shortened after long-term idleness; therefore, users should power on and run the servo drive at an interval of at least half a year.

Chapter 12 Accessories

12.1 Accessories Model List

Name	Model	Application
Filter	DL-35EBK5	4R4/5R5
	DL-50EBK5	7R5/011/015
	DL-65EBK5	018/025
	DL-100EBK5	030/037
	DL-130EBK5	045/055
	DL-160EBK5	075
AC reactor	ACL2-5R5-4	4R4/5R5
	ACL2-015-4	7R5/011/015
	ACL2-022-4	018/025
	ACL2-037-4	030/037
	ACL2-055-4	045/055
	ACL2-075-4	075
Brake resistor	40Ω, 500W	4R4/5R5/7R5/011
	15Ω, 500W	015/018/025
	10Ω, 2000W	030/037
	10Ω, 2000W (2pcs connected in parallel)	045/055
	30Ω, 2000W (2pcs connected in parallel)	075
Brake unit	DBU100H-060-4	075
Pressure sensor	U5176-000005-250BG	
Current junction box		During refit, if the output signal of master PC is current signal, it is necessary to convert it to voltage type with junction box
External HMI commissioning panel	H038-HA	Commissioning tool

12.2 Noise Filter

(1) The noise filter models for each drive type

Servo Drive Model	Noise Filter	
	Model	Specification
SV-MH800-4R4-33-S00 SV-MH800-5R5-33-S00	DL-35EBK5	35A,200nF

Servo Drive Model	Noise Filter	
	Model	Specification
SV-MH800-7R5-33-S00 SV-MH800-011-33-S00 SV-MH800-015-33-S00	DL-50EBK5	50A,320nF
SV-MH800-018-33-S00	DL-65EBK5	65A,320nF
SV-MH800-025-33-S00	DL-65EBK5	65A,320nF
SV-MH800-030-33-S00	DL-100EBK5	100A,320nF
SV-MH800-037-33-S00	DL-100EBK5	100A,320nF
SV-MH800-045-33-S00	DL-130EBK5	130A,690nF
SV-MH800-055-33-S00	DL-130EBK5	130A,690nF
SV-MH800-075-33-S00	DL-160EBK5	160A,690nF

(2) Filter terminal definition

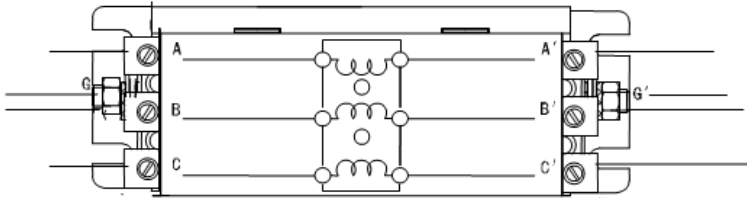

Mark	Definition
A	Input 3PH power
B	
C	
G	Input power ground
A'	Output 3PH power
B'	
C'	
G'	Output power ground

(3) Filter model dimension (mm)

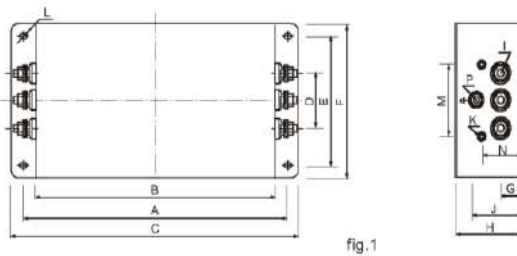

fig.1

Model	A	B	C	D	E	F	G	H	I	J	K	M	N	P	L
DL-35EBK5	243	224	265	58	70	102	25	92	M6	58	M4	74	49	M6	6.4×9.4
DL-50EBK5															
DL-65EBK5															
DL-100EBK5	354	323	388	66	155	188	30	92	M8	62	M4	86	56	M8	6.4×9.4
DL-130EBK5															
DL-160EBK5															

Fix the noise filter in a well-ventilated place with bolts. The grounding terminal of input and output must be connected to the system ground in a reliable way. See [4.6.6](#) for connection modes.

12.3 Brake Resistor Model Selection and Installation

1) The reference table for brake resistor and brake unit

Servo Drive Model	Brake Resistor Specification		Brake Unit Specification
	Resistor Value Ω	Power W	
SV-MH800-4R4-33-S00	40	500	Built-in brake unit
SV-MH800-5R5-33-S00	40	500	
SV-MH800-7R5-33-S00	40	500	
SV-MH800-011-33-S00	40	500	
SV-MH800-015-33-S00	15	500	
SV-MH800-018-33-S00	15	500	
SV-MH800-025-33-S00	15	500	
SV-MH800-030-33-S00	10	2000	
SV-MH800-037-33-S00	10	2000	
SV-MH800-045-33-S00	5	4000 (2pcs 10 Ω /2000kW connected in parallel)	
SV-MH800-055-33-S00	5	4000 (2pcs 10 Ω /2000kW connected in parallel)	
SV-MH800-075-33-S00	15	4000 (2pcs 30 Ω /2000kW connected in parallel)	DBU100H-060-4

Built-in brake unit is included for servo drives of 55kW and below; for 75kW and above models, users need to install external brake unit. As the drive does not carry brake resistor, external brake resistor is a must. If the motor brakes frequently and brake resistor of larger power is needed, users can select the brake resistor which carries small resistance value and large power during ordering. External brake resistor should be installed in a well-ventilated place and away from combustible objects and non-heat resistant parts.

When users select the external brake resistor by themselves, note that the resistance value cannot be lower than the specified value; otherwise the drive may be damaged.

2) Brake resistor dimension (mm)

Brake resistors RXLG-500W-40R and JRXLG-500W-15RJ with aluminum case (used in 4R4/5R5/7R5/011/015 drive) are shown below:

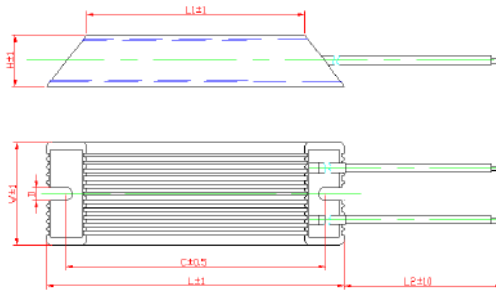

Brake resistors RXLG-2000W-10RJ with aluminum case (used in 030/037 drive, used in 045/055 drive with 2pcs connected in parallel) and RXLG-2000W-30RJ (used in 075 drive with 2pcs connected in parallel) are shown below:

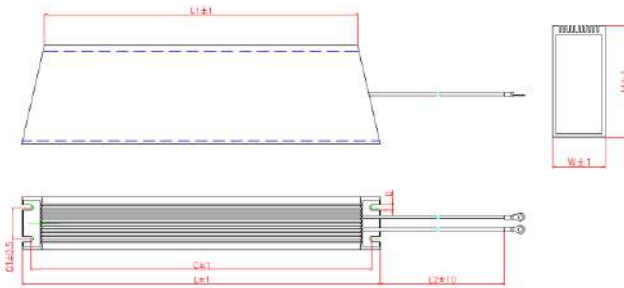

Model	L	L1	W	H	C	C1	D	L2
RXLG-500W-15R J RXLG-500W-40R J	335	290	60	30	315		5.6	1000
RXLG-2000W-10R J RXLG-2000W-30R J	550	510	50	107	530	30.5	5.5	1000

3) Installation and layout of brake resistor

All the resistors must be installed in well-cooled places.

	<p>⚡ The materials surrounding the brake resistor/brake unit must be fire-retardant. The surface temperature of the resistor is very high, which cause the temperature of the air flowing above the resistor to reach hundreds of centigrade; therefore, the materials must be prevented from contacting the resistor.</p>
--	--

Installation of the brake resistor:

	<ul style="list-style-type: none"> ⚡ For 55kW and below models, only external brake resistor is needed. ⚡ PB and(+) are the cable terminals of the brake resistor.
--	--

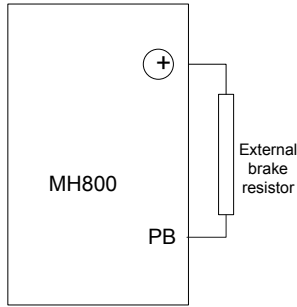

Installation of brake unit:

	<ul style="list-style-type: none"> ◇ For 75kW and above models, external brake unit is needed. ◇ (+)and(-) are connection terminals of brake unit. ◇ The length of the connection wire between (+)and(-) terminals of the inverter and (+), (-) terminals of the brake unit should be less than 5m; the wiring length of BR1 and BR2 of brake unit and the both ends of the brake resistor should be less than 10m.
---	--

Connection of single unit is shown below:

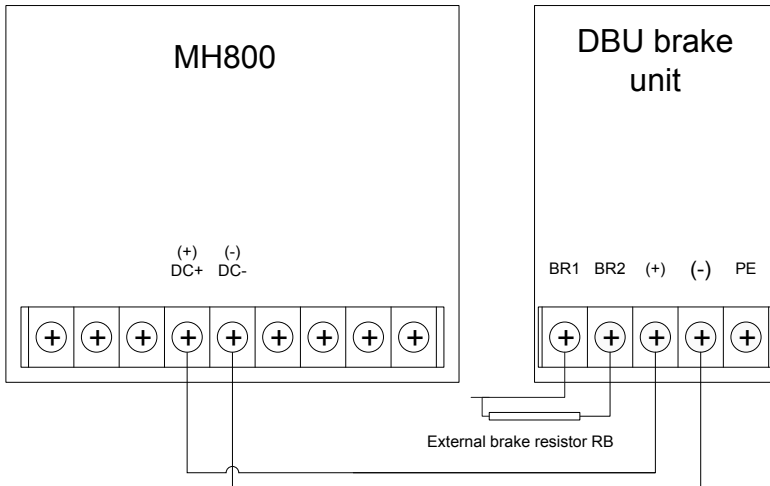

a) SV-MH800-4R4/5R5/7R5/011/015/018/025/030/037 drive and brake resistor layout (mm)

Spec.: 500W 40Ω
Qty: 1

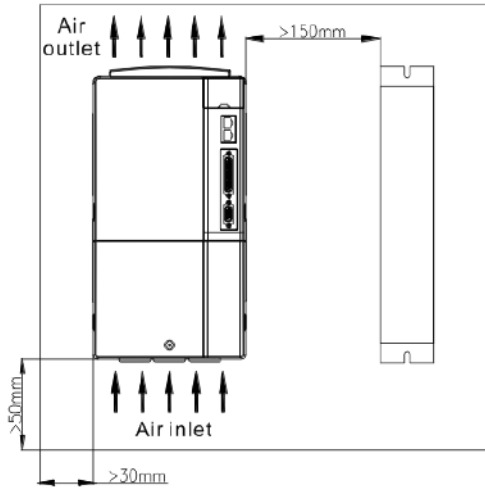

b) Layout of SV-MH800-045/055/075 drive and brake resistor (mm)

Spec.: 2000W 30Ω
Qty: 2 (parallel connection)

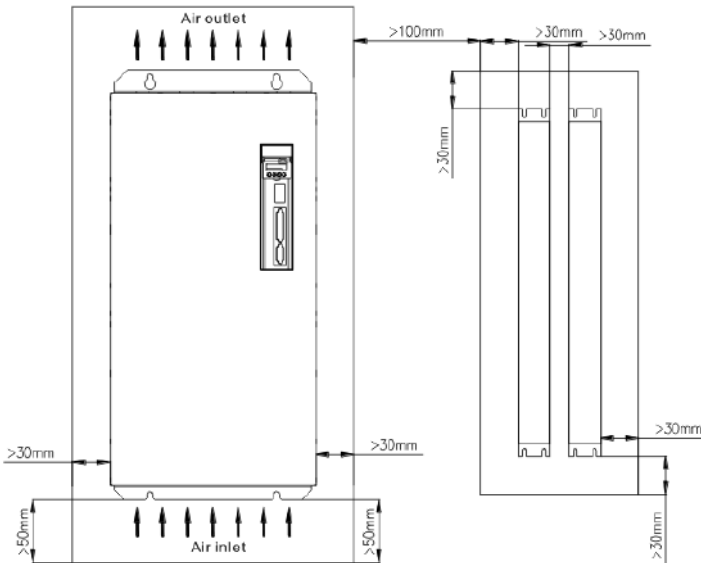

12.4 Pressure Sensor

1) Pressure sensor terminal

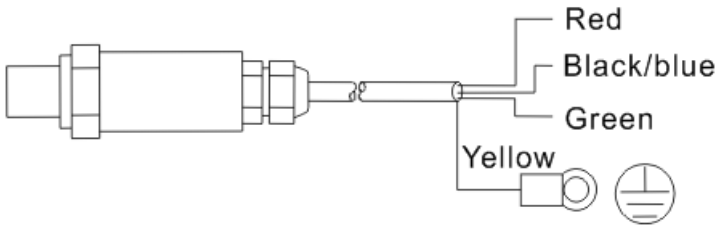

Color	Name	Definition
Red	+15V	15V power
Black/blue	AGND	Pressure analog signal output
Green	AIN3+	
Yellow	PE	Connect ground line

2) Dimension and installation of pressure sensor

Voltage output:

Pin 1: power+

Pin 2: output-

Pin 3: power-

Pin 4: grounding

4~20mA output:

Pin 1: power+

Pin 2: power+

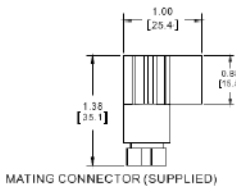

HIRSCHMANN MATING Connector

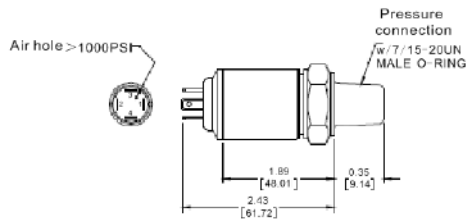

HIRSCHMANN CONNECTOR DIN 43650-C

IP65

Teflon tape should be used when pressure sensor is connected to oil circuit. During installation, screw tight the pressure sensor to prevent leakage.

12.5 External HMI Options

Refer to [5.1 External HMI Display and Operation](#) for details.

Chapter 13 Contact Us

INVT Industrial Technology (Shanghai) Co., Ltd.

Address: Building No. 1, No. 188, Xinjun Ring Road, Pujiang Hi-tech Park, Shanghai

Postal code: 201114

Tel.: +86-21-34637660

Fax: +86-21-34637667

Website: www.invt-tech.com

Shengze Office

Address: No. 126, Building No. 16, Xujing Garden, Shengze Town, Wujiang City, Jiangsu

Tel.: +86-512-63537191

Fax: +86-512-63537191

South China Office

Address: 6F,5# Building, Gaofa Industrial Park, Longjing, Nanshan District, Shenzhen, China

Tel.: +86-755-26966810, 26966997

Fax: +86-755-26966252

Shunde Office

Address: Room 308, Tower B, Zicuixuan, Linglan Garden, Guozhong Road, Daliang, Shunde District, Foshan City, Guangdong Province

Tel.: +86-757-22913340

Fax: +86-757-22913340

Ningbo Office

Address: Room 433, No. 66, Venture Building, Yuanshi Road, Hi-tech Zone, Ningbo City

Tel.: +86-0574-87914636 (switchboard)

Fax: +86-0574-87914638 (fax)

North China Office

Address: Room 2101, Unit 1, Building No. 5, Guohua Classics, No. 30, Jiefang Road, Ji'an City

Tel.: 0531-81186860

Fax: 0531-88873650

Wuxi Office

Address: Room 1001, Building No. 65, Kuangqiaolijing, Beitang District, Wuxi City, Jiangsu Province

Tel.: 0510-82390516

Fax: 0510-82390516



Service line: 400-700-9997 ; +86-21-34637660 Website: www.invt-tech.com

INVT INDUSTRIAL TECHNOLOGY (SHANGHAI) CO.,LTD.

No. 1 Building, No. 188 New Junhuan Road, Pujiang High Tech Park, Minhang District, Shanghai

Industrial Automation: ■ Frequency Inverter ■ Servo & Motion Control ■ Motor & Electric Spindle ■ PLC
■ HMI ■ Intelligent Elevator Control System ■ Traction Drive
Electric Power ■ SVG ■ Solar Inverter ■ UPS ■ Online Energy Management System



66001-00530

INVT Copyright.

Information may be subject to change without notice during product improving.

201804 (V1.0)