

# MH800 Hydraulic Servo System



Product Introduction..... 2

Hydraulic Equipment Dedicated Solutions..... 3

Servo Drive Performance Specification Table..... 4

Product Description Servo Drives..... 5

Servo Drive Installation Size..... 6

Servo Motor Product Description..... 7

Drive Terminal Layout.....10

Drive Standard Wiring Diagram.....11

Single Pump Control System.....12

System Selection.....17

Hydraulic Servo Configuration Tables.....18

Product application.....19

Sales Network.....20

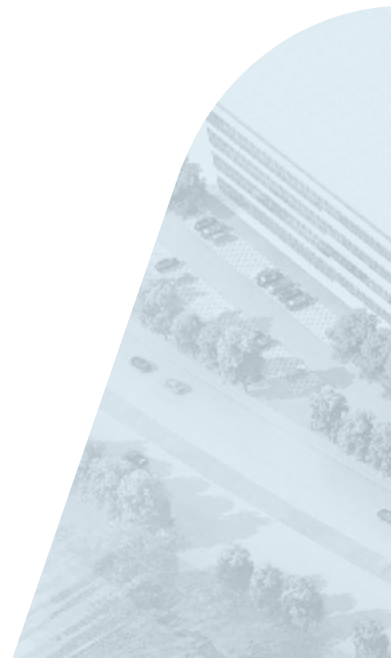

## / Product introduction

MH800 series of electro-hydraulic servo system is designed base on study of injection molding machine and hydraulic mechanical technological process, which is type of upgraded series high performance hydraulic servo system. With advanced High performance vector control, its easily implement lean extraordinary quality of high efficiency, energy conservation and environmental protection; Abundant power and communication interface, easily to realize more centralized intelligent control devices network and smart automation production line. This type of hydraulic servo system combines with Environmental performance of super stability and tolerance, to achieve the perfect combination of machine and the environment...

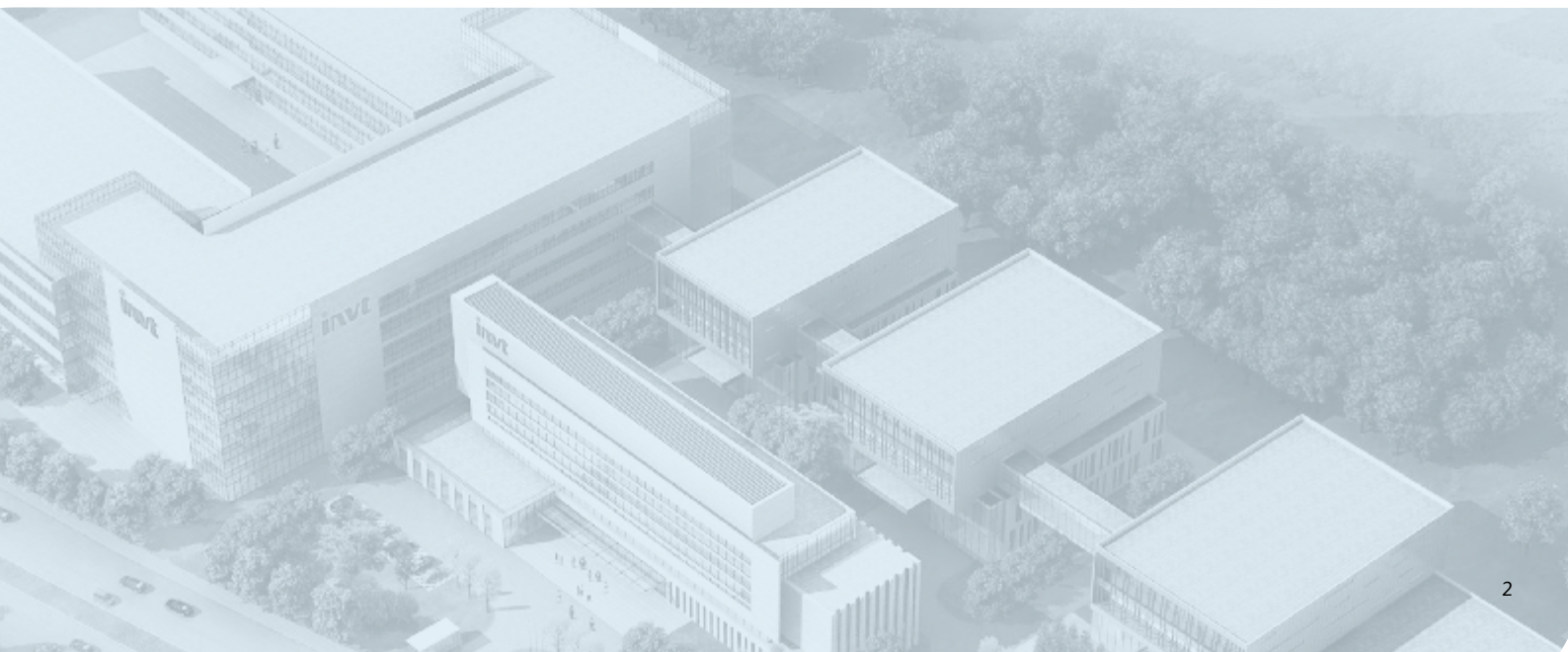

# / Hydraulic equipment dedicated solutions

---

- 1 Meeting the demand of environment protection which focuses on low noise and weakening electromagnetic interference in the application sites for the customers.
- 2 Adapt to worse grid, temperature, humidity and dust with a better performance of anti-tripping and improved the reliability.
- 3 Monitor the temperature change of the motor and drive all the way, real-time adjustment system overload limiter, guarantee the safe and stable operation of motor and drive, extending the service life of the system.
- 4 Product's power from 4.4 kW to 75 kW, meet small vertical injection molding machine, injection molding machine, die-casting machine, hydraulic machine, bottle blowing machine, aluminum extrusion machine, cutting plate bending machine, etc., to meet the requirements of hydraulic equipment industry.
- 5 Using fuzzy control principle to achieve smooth conversion between flow and pressure control modes, at the flow control and pressure control mode frequent conversion system.
- 6 Simple gain adjustment and gain switching function, support the four groups gain setting, IO input, communication or internal variables to gain switch, to adapt to the process of the process requirements.
- 7 Through pressure release speed and pressure torque setting, cooperate to dump, real-time pump locked-rotor check and reset function, realizes the minimum amount of reverse pressure control, prolong the service life of pump.
- 8 Have a lot of communication interface, support the MODbus, CANopen, EtherCAT bus communication protocol, etc. Can be achieved by networking mold protection, energy management, remote monitoring, etc.
- 9 Through arbitrary distribution parameters, 6 switch input and four switch output function. With LED panel or external HMI to modify, easy to operate.

# Servo drive performance specification table

MH800 hydraulic servo series			
Specification	Instruction		
Basic specifications	Control mode	Three-phase full wave rectifier and IGBT PWM control sine wave current drive mode	
	Max. output frequency	400 Hz	
	Motor position sensor	Rotating transformer, resolution 4096 / rev	
	working condition	Use/storage temperature	-20 ~ +55 °C ( ≥45 °C derating use ) / -20 ~ +85 °C
		Humidity	≤95%RH (Shall not be dew)
		Air	Indoor (not sun), no corrosive gas, flammable gas, oil and gas, no dust
		Altitude	≤2000m
	Protection grade	IP20	
	Cooling way	Forced air cooling	
	Digital signal	Input	6 inputs: ①servo enable(S-ON)②alarm clearance(ALM-RST) ③4external control interface ( I1,I2,I3,I4, )
		Output	4 outputs: ①alarm output(ALM)②ready(S-RDY)③control output 1 relay output: Double displacement pump displacement output switch control(O1)
	Analog signal	Input	3 inputs 10 bit A/D (AIN1, AIN2, AIN3)
		Output	2 Outputs 10bit D/A (ANOUT1, ANOUT2) Can through the LED panel or external HMI set internal parameters of the output
	Power output	Provide benchmark 15 v power supply	
	Communi- cation	CAN	And PC computer communication, to set parameters and drive control, command, given parameters, and other functions.(using RS485 communication function, the LED display panel and the external HMI) cannot be used
RS485			
LED display panel and the keyboard	6 bit LED display, 4 functional keys		
External HMI	External HMI communicate with driver though RS485, realize the parameter setting, driver control, given command, and the parameter saving functions		
Control performance	Control mode	Through the parameter is set to choose one of two modes: (1) process control (2) speed control	
	Control input	The hydraulic control command input: can be set to the analog input, CAN communication, or RS485 communication Speed command input: the CAN communication or RS485 communication	
	Parallel multi-pump control	Can control 16 pump, three works mode (multi-pump, compound, multi-mode)	
	Pressure control precision	± 1bar	
	Flow control accuracy	± 0.5%FS	
	Pressure control step response	≤ 100ms ,The flow of a given>70%(screw pump)	
	Step response speed when the flow control	≤ 50ms, Feedback pressure is less than 10 bar	
	Flow correction function	According to the feature of various kinds of pump to output flow pressure correction	
	Speed command input	RS485,CAN	
	Speed control precision	± 0.5%	
	Torque response time	≤2ms	
Overload capacity	MH800-4R4-33,MH800-5R5-33,MH800-7R5-33,MH800-018-33,MH800-030-33,MH800-037-33, MH800-045-33,MH800-055-33 141% rated current for 5 minutes, MH800-011-33,MH800-015-33,MH800-025-33,MH800-075-33,130% rated current for 5 minutes, the maximum output current for 30 seconds.		
Protection function	Hardware error	Over-current. Dc overvoltage. Dc undervoltage. Braking resistor damage. Module overtemperature. Pressure sensor fault. Positive and negative to speeding. Brake overload, etc	
	Software error	Software failures, re-enter, etc	
	Alarm record memory	Can store 5 alarm record	

# Product description servo drives

## Naming rules

# SV-MH800-5R5-33-S 00

①                      ②                      ③                      ④                      ⑤                      ⑥

①

Symbol	Product type
SV	Servo products

③

Symbol	Power level
4R4	4.4kW
011	11kW

⑤

Symbol	Communication type
S	Standard form
N	EtherCat main line

②

Symbol	Power level
MH800	Electric hydraulic products

④

Symbol	Voltage input type
33	Three phase 380v
32	Three phase 220v
22	Single-phase 220v

⑥

Symbol	Spreading code
00	Common type
01	ChenHsong special type
02	Beston special type

Drive Model: SV-MH800-	4R4-33-S00	5R5-33-S00	7R5-33-S00	011-33-S00	015-33-S00
Apply to motor capacity	4.4(kW)	5.5(kW)	7.5(kW)	11(kW)	15(kW)
Rated output current	13A	18A	22A	26A	30A
Rated input current	18A	24A	28A	32A	37A
Maximum current output	25A	35A	46A	53A	64A
Mains input	AC380V(-15%)-440V(+10%) 47Hz~63Hz				
Net weight	6.5kg	7.0kg	9kg	9.5kg	9.5kg
Braking resistor	40Ω 500W				15Ω500W

Drive Model: SV-MH800-	018-33-S00	025-33-S00	030-33-S00	037-33-S00	045-33-S00
Apply to motor capacity	18(kW)	25(kW)	30(kW)	37(kW)	45(kW)
Rated output current	38A	50A	64A	80A	99A
Rated input current	47A	60A	75A	94A	109A
Maximum current output	95A	113A	141A	190A	255A
Mains input	AC380V(-15%)-440V(+10%) 47Hz~63Hz				
Net weight	11.5kg	11.5kg	30kg	32kg	51kg
Braking resistor	15Ω 500W		10Ω 2000W		5Ω 4000W

Drive Model: SV-MH800-	055-33-S00	075-33-S00
Apply to motor capacity	55(kW)	75(kW)
Rated output current	123A	156A
Rated input current	135A	166A
Maximum current output	283A	318A
Mains input	AC380V(-15%)-440V(+10%) 47Hz~63Hz	
Net weight	52 Kg	67Kg
Braking resistor	5Ω 4000W	15Ω 4000W, The brake unit: DBU100H - 060-4

# Servo drive installation size

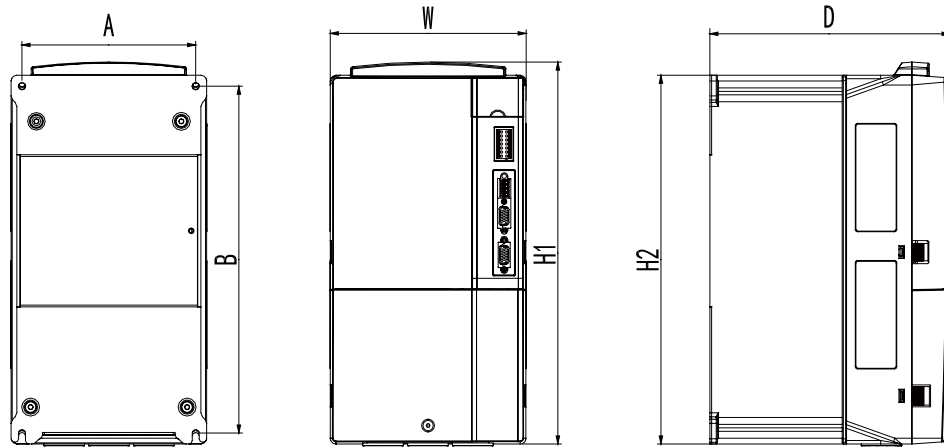

4.4kW-25kW

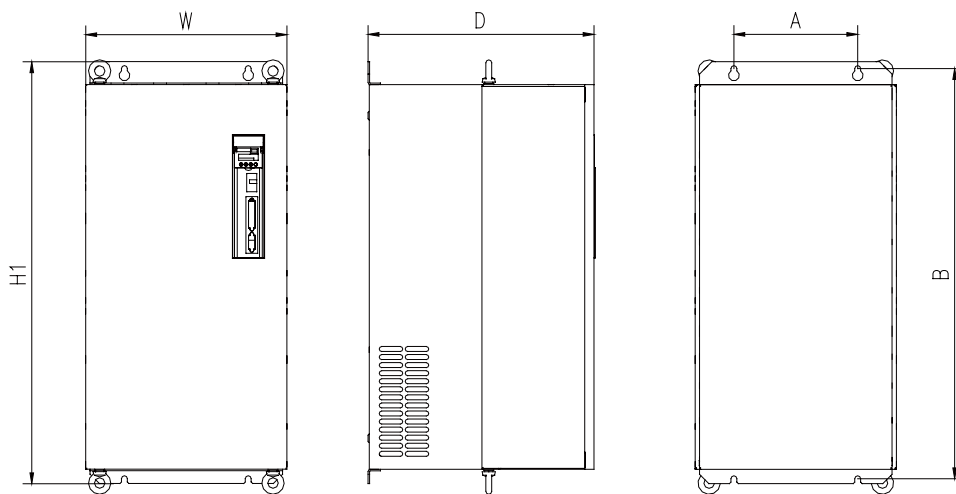

30kW-75kW

Drive Model	Boundary dimension			Installation dimensions		Install the aperture (mm)
	H1 (mm)	W (mm)	D (mm)	A (mm)	B (mm)	
SV-MH800-4R4-33-S-00	332	170	208	151	301	M5(φ6)
SV-MH800-5R5-33-S-00						
SV-MH800-7R5-33-S-00						
SV-MH800-011-33-S-00	342	230	208	210	311	M5(φ6)
SV-MH800-015-33-S-00						
SV-MH800-018-33-S-00	407	255	245	237	384	M6(φ7)
SV-MH800-025-33-S-00						
SV-MH800-030-33-S-00	555	270	325	130	540	M6(φ7)
SV-MH800-037-33-S-00						
SV-MH800-045-33-S-00	554	338	329	200	535	M8(φ9.5)
SV-MH800-055-33-S-00						
SV-MH800-075-33-S-00	680	325	365	200	661	M8(φ9.5)

# Servo motor product description

## Naming rules

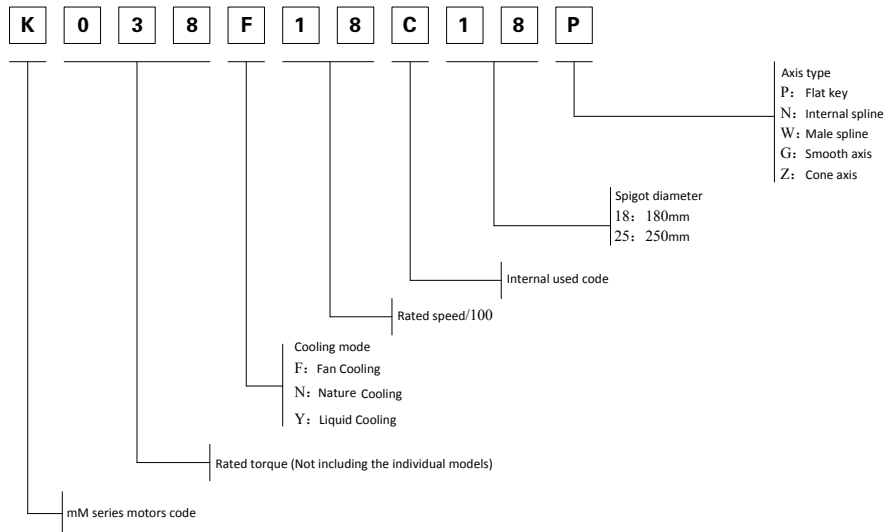

## Naming rules

**SV-ML 06-4R4 G-2-1 A 0 A**

①      ②      ③      ④      ⑤      ⑥      ⑦      ⑧      ⑨      ⑩

①

Symbol	Product category
SV	Servo system

②

Symbol	Inertia Class
ML	Small
MM	Middle

③

Symbol	Seat No.
18	180mm
25	250mm

④

Symbol	Rated power
4R4	4.4kW
5R5	5.5kW

⑤

Symbol	Rated speed
A	1000rpm
B	1500rpm
E	2000rpm

⑥

Symbol	Voltage grade
2	220VAC
4	380VAC

⑦

Symbol	Encoder type
0	Without encoder
7	12 bit rotating transformer
8	16 bit rotating transformer

⑧

Symbol	Shaft end connection
A	Have a solid key screw holes(standard)
01	Solid axis

⑨

Symbol	Optional
0	There are oil seal, no brake
1	No oil seal, no brake

⑩

Symbol	Vendor code
1	Jun weft

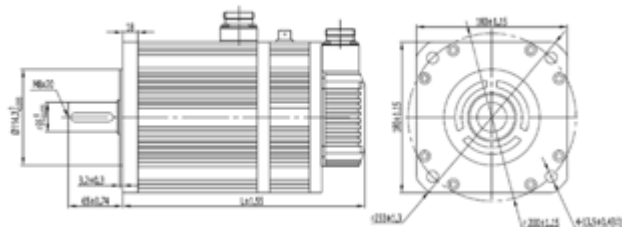

SV-MM18-4R4B-4-7A01 L: 262mm  
 SV-MM18-5R5B-4-7A01 L: 292mm



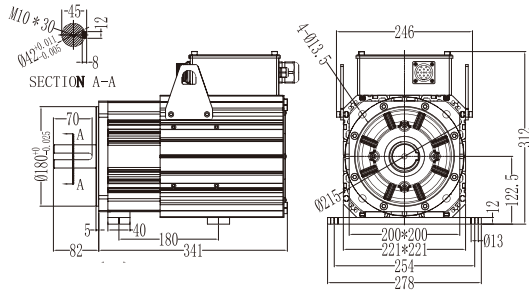

Model Size: K038F18C18P / K036F20C18P

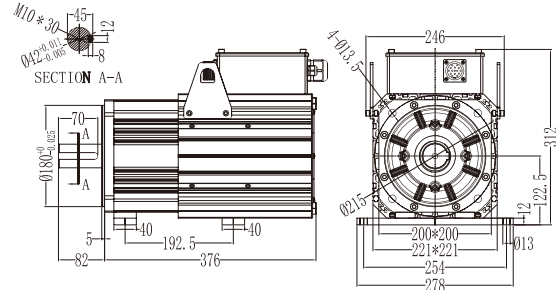

Model Size: K058F18C18P

Specification	PCD size	Casing length	Flange diameter	Weight	Insulation class	Protection grade	Cooling method	Working method	Certification	Motor temperature sensor	
SV-MM18-4R4B-4-7A01	180mm	262mm	114.3mm	25.5kg	F	IP65	Natural cooling	Continuous S1	CE	KTY84-130/PT1000	
SV-MM18-5R5B-4-7A01	180mm	292mm	114.3mm	30.5kg	F	IP65	Natural cooling	Continuous S1	CE	KTY84-130/PT1000	
K038F18C18P	200mm	210mm	180mm	36.2kg	F	IP54	Air cooling	Continuous S1	CE	KTY84-130/PT1000	
K036F20C18P	200mm	210mm	180mm	36.3kg	F	IP54	Air cooling	Continuous S1	CE	KTY84-130/PT1000	
K058F18C18P	200mm	245mm	180mm	42.7kg	F	IP54	Air cooling	Continuous S1	CE	KTY84-130/PT1000	
K060F18C18P	200mm	245mm	180mm	42.6kg	F	IP54	Air cooling	Continuous S1	CE	KTY84-130/PT1000	
Electrical parameters	Rated power	Rated torque	Rated current	Rated voltage	Torque constant	Rated speed	Maximum speed	Back-EMF constant	Winding resistor	Winding inductance	EMC/EMI
SV-MM18-4R4B-4-7A01	4.4kW	27Nm	10A	380V	2.7 Nm/A	1500rpm	2500rpm	1.72v/s	0.792 Ω	4.83mH	IEC61800-3
SV-MM18-5R5B-4-7A01	5.5kW	35Nm	12A	380V	2.9Nm/A	1500rpm	2500rpm	1.81v/s	0.620 Ω	4mH	IEC61800-3
K038F18C18P	7.5kW	38Nm	12.9A	367V	2.97Nm/A	1800rpm	2500rpm	1.72v/s	0.700 Ω	9.3mH	IEC61800-3
K036F20C18P	7.5kW	36Nm	17.6A	367V	2.05Nm/A	2000rpm	2500rpm	1.19v/s	0.480 Ω	6.5mH	IEC61800-3
K058F18C18P	11kW	58Nm	20.0A	367V	2.90Nm/A	1800rpm	2500rpm	1.72v/s	0.410 Ω	5.88mH	IEC61800-3
K060F18C18P	11kW	58Nm	26.6A	367V	2.18Nm/A	1800rpm	2500rpm	1.31v/s	0.290 Ω	4.8mH	IEC61800-3

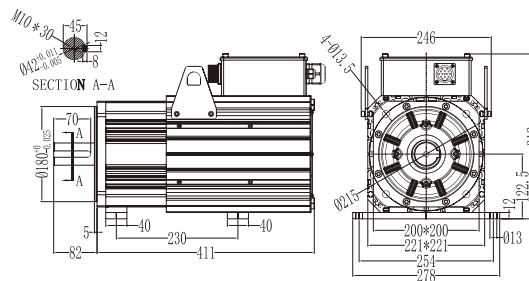

Model Size: K072F18C18P

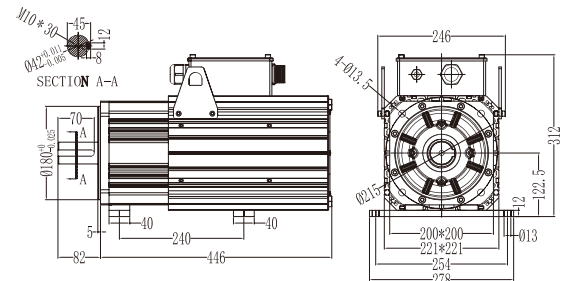

Model Size: K078F20C18P / K091F15C18P

Specification	PCD size	Casing length	Flange diameter	Weight	Insulation class	Protection grade	Cooling method	Working method	Certification	Motor temperature sensor	
K072F18C18P	200mm	280mm	180mm	49.5kg	F	IP54	Air cooling	Continuous S1	CE	KTY84-130/PT1000	
K072F20C18P	200mm	280mm	180mm	48.1kg	F	IP54	Air cooling	Continuous S1	CE	KTY84-130/PT1000	
K078F20C18P	200mm	315mm	180mm	56.9kg	F	IP54	Air cooling	Continuous S1	CE	KTY84-130/PT1000	
K091F15C18P	200mm	315mm	180mm	56.6kg	F	IP54	Air cooling	Continuous S1	CE	KTY84-130/PT1000	
Electrical parameters	Rated power	Rated torque	Rated current	Rated voltage	Torque constant	Rated speed	Maximum speed	Back-EMF constant	Winding resistor	Winding inductance	EMC/EMI
K072F18C18P	13kW	72Nm	26.7A	367V	2.70Nm/A	1800rpm	2500rpm	1.61v/s	0.310 Ω	4.8mH	IEC61800-3
K072F20C18P	15kW	72Nm	32.0A	367V	2.25Nm/A	2000rpm	2500rpm	1.44v/s	0.260 Ω	3.9mH	IEC61800-3
K078F20C18P	15kW	72Nm	32.0A	367V	2.25Nm/A	2000rpm	2500rpm	1.34v/s	0.170 Ω	2.9mH	IEC61800-3
K091F15C18P	15kW	91Nm	30.3A	367V	3.00Nm/A	1500rpm	2200rpm	1.80v/s	0.310 Ω	5.0mH	IEC61800-3

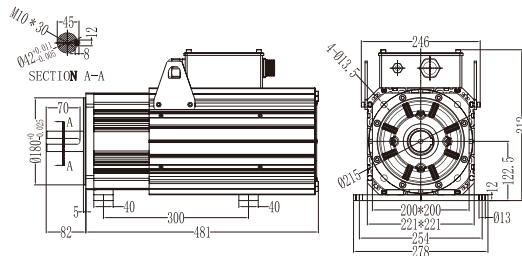

Model Size: K105F20C18P / K111F15C18P

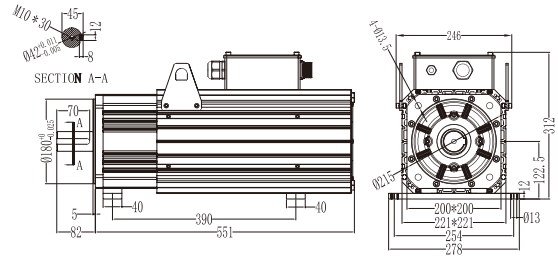

Model Size: K132F18C18P

Specification	PCD size	Casing length	Flange diameter	Weight	Insulation class	Protection grade	Cooling method	Working method	Certification	Motor temperature sensor	
K105F20C18P	200mm	350mm	180mm	63.6kg	F	IP54	Air cooling	Continuous S1	CE	KTY84-130/PT1000	
K111F15C18P	200mm	350mm	180mm	63.4kg	F	IP54	Air cooling	Continuous S1	CE	KTY84-130/PT1000	
K132F18C18P	200mm	420mm	180mm	76.6kg	F	IP54	Air cooling	Continuous S1	CE	KTY84-130/PT1000	
K130F22C18P	200mm	420mm	180mm	76.6kg	F	IP54	Air cooling	Continuous S1	CE	KTY84-130/PT1000	
Electrical parameters	Rated power	Rated torque	Rated current	Rated voltage	Torque constant	Rated speed	Maximum speed	Back-EMF constant	Winding resistor	Winding inductance	EMC/EMI
K105F20C18P	22kW	105Nm	45.0A	367V	2.50Nm/A	2000rpm	2500rpm	1.44v/s	0.170Ω	2.8mH	IEC61800-3
K111F15C18P	18kW	111Nm	32.8A	367V	3.50Nm/A	1500rpm	2200rpm	2.10v/s	0.290Ω	5.7mH	IEC61800-3
K132F18C18P	25kW	132Nm	48.6A	367V	3.00Nm/A	1800rpm	2500rpm	1.76v/s	0.160Ω	2.9mH	IEC61800-3
K130F22C18P	25.8kW	112Nm	54.0A	367V	2.40Nm/A	2200rpm	2500rpm	1.42v/s	0.120Ω	2.0mH	IEC61800-3

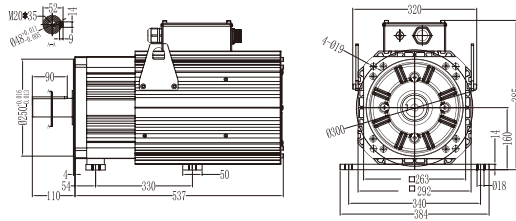

Model Size: K187F18C25P

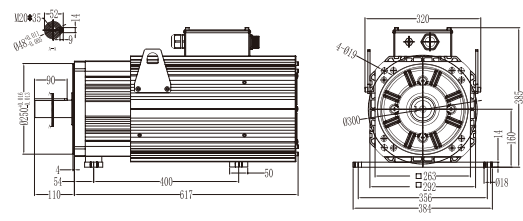

Model Size: K235F20C25P

Specification	PCD size	Casing length	Flange diameter	Weight	Insulation class	Protection grade	Cooling method	Working method	Certification	Motor temperature sensor	
K187F18C25P	263mm	380mm	250mm	115.1kg	F	IP54	Air cooling	Continuous S1	CE	KTY84-130/PT1000	
K208F15C25P	263mm	380mm	250mm	115.3kg	F	IP54	Air cooling	Continuous S1	CE	KTY84-130/PT1000	
K235F20C25P	263mm	460mm	250mm	144.1kg	F	IP54	Air cooling	Continuous S1	CE	KTY84-130/PT1000	
K290F18C25P	263mm	510mm	250mm	156kg	F	IP54	Air cooling	Continuous S1	CE	KTY84-130/PT1000	
K341F18C25P	263mm	577mm	250mm	196kg	F	IP54	Air cooling	Continuous S1	CE	KTY84-130/PT1000	
Electrical parameters	Rated power	Rated torque	Rated current	Rated voltage	Torque constant	Rated speed	Maximum speed	Back-EMF constant	Winding resistor	Winding inductance	EMC/EMI
K187F18C25P	35kW	187Nm	74.6A	367V	2.58Nm/A	1800rpm	2500rpm	1.59v/s	0.078Ω	2.3mH	IEC61800-3
K208F15C25P	27kW	172Nm	58.1A	367V	3.30Nm/A	1500rpm	2000rpm	1.96v/s	0.120Ω	3.2mH	IEC61800-3
K235F20C25P	50kW	235Nm	113.0A	367V	2.30Nm/A	2000rpm	2500rpm	1.40v/s	0.050Ω	1.1mH	IEC61800-3
K290F18C25P	55kW	290 Nm	114A	380V	2.55Nm/A	1800rpm	2500rpm	1.47v/s	0.031Ω	1.16 mH	IEC61800-3
K341F18C25P	61kW	341.6Nm	155.3A	380V	2.20Nm/A	1800rpm	2500rpm	1.34v/s	0.025Ω	1.17mH	IEC61800-3

# Drive terminal layout

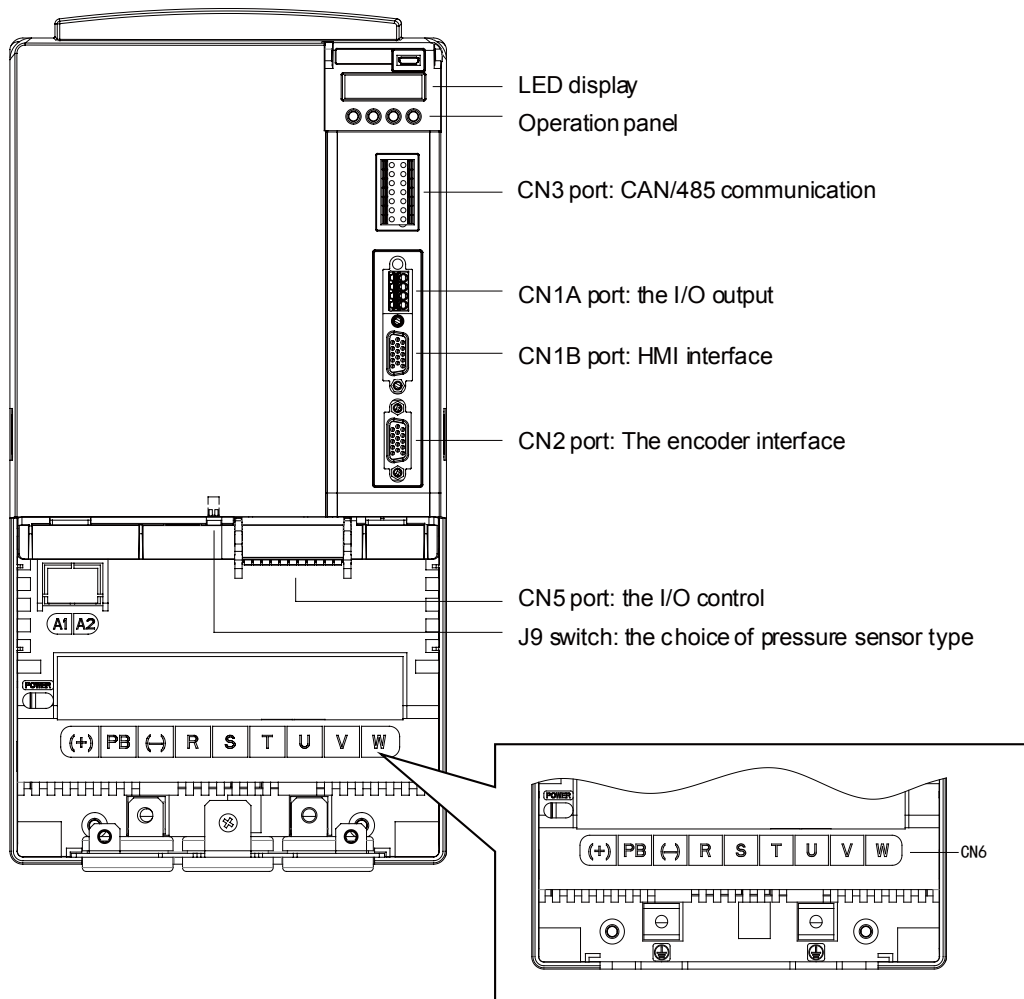

# Drive standard wiring diagram

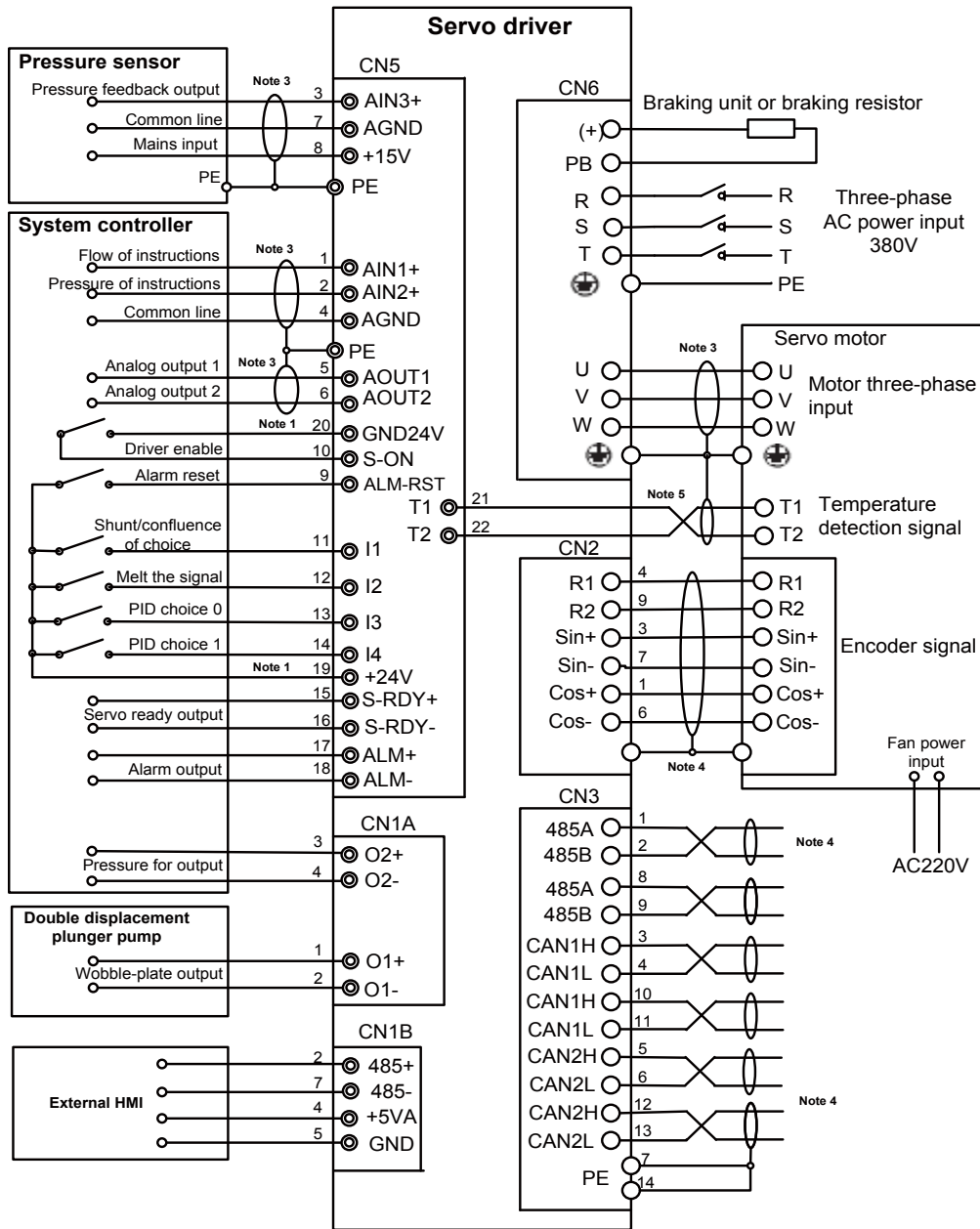

Note 1: in the wiring diagram, the digital input signal using the system controller power to drive, CN5 connector' 24V power from the external. The power of the pressure sensor can also be used drive internal power supply. By jumper J1 to 15 v, connect the + 15 v and + 24 v, through the jumper J2 to 15 v, connect the AGND and GND24V. Drives the factory default J1 and J2 jumper to 15 v side, using drive pressure sensor power supply.

Note 2: the power of the drive pressure sensor is 15 v, to accept the pressure signal is 0 ~ 10 v or 1-5 v voltage signal; You can set the J9 on the circuit board control.

Note 3: to prevent undesired signal impacting on the drives, it is suggested that all analog signal drives lines and 3-phase input lines of the motor adopted the shielded cables , with the shielding layer grounded.

Note 4: the encoder lines and communication lines must use twisted-pair shielded cable, shielding layer to ground. Communication line head and tail should be matching with terminal resistance. The driver CAN communication signal connector has built-in 10 k Ω terminal resistance. 485 communication signal connector has a built-in 1 k Ω terminal resistance.

Note 5: prevent jamming signals affect motor temperature sampling, it is recommended to use twisted-pair cable. The driver support two temperature sensor temperature sampling, KTY84 and Pt1000, by setting the motor temperature sensor parameter selection support type of temperature sensor.

# Single pump control system

## Single pump control system

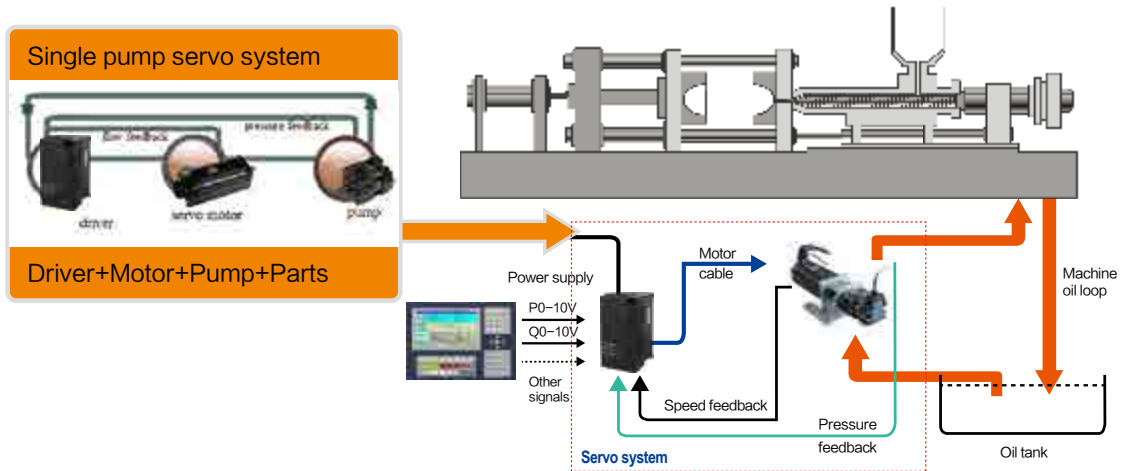

INVT offer complete servo electro-hydraulic combination products:

1. 4.4 ~ 75 kW of electro-hydraulic servo system can completely satisfy the amount of under 500 t injection molding machine;
2. Can drive the oil pump 16 ~ 160 ml/r, satisfy the system flow of 32 ~ 320 L/min.

## Multiple pump system

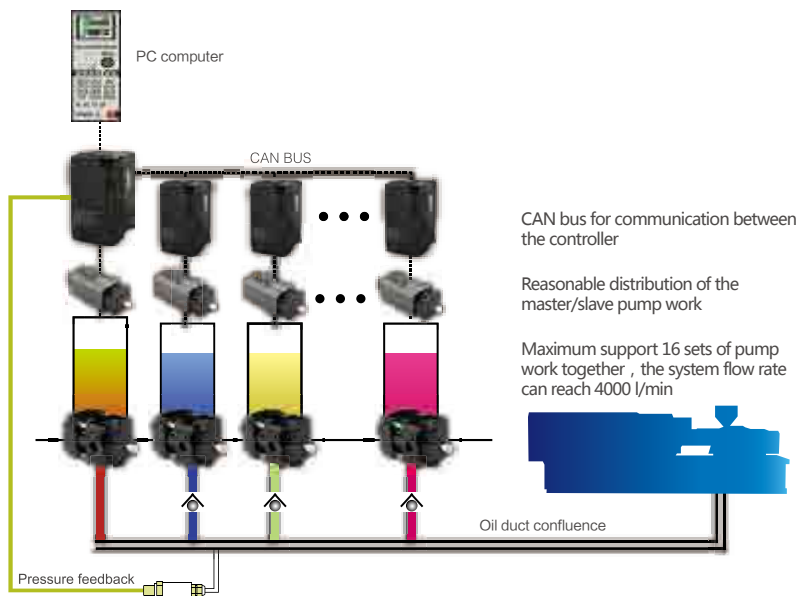

Ordinary Multi – pump control system of the confluence

Ordinary Multi – pump control mode of the confluence wiring diagram

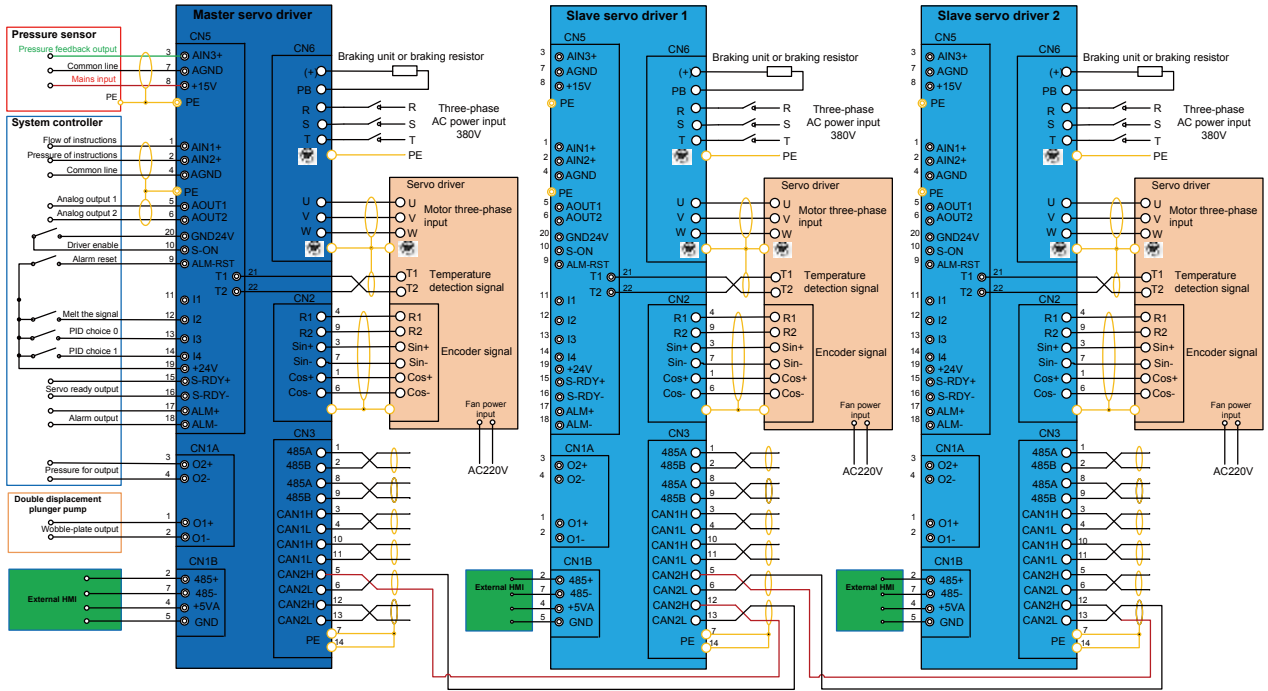

Ordinary Multi – pump confluence system schematic diagram

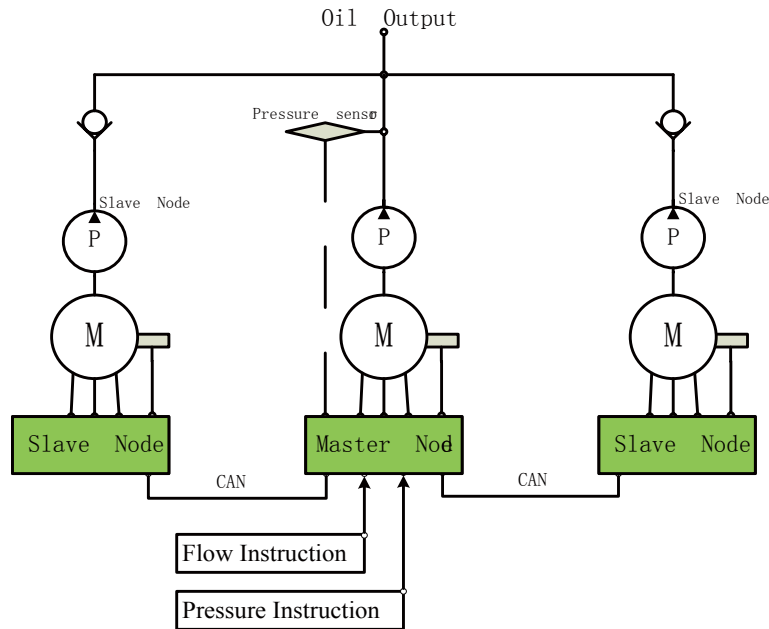

## The compound mode and multi-mode control system of the confluence

### The compound mode and multi-mode control system of the confluence wiring diagram

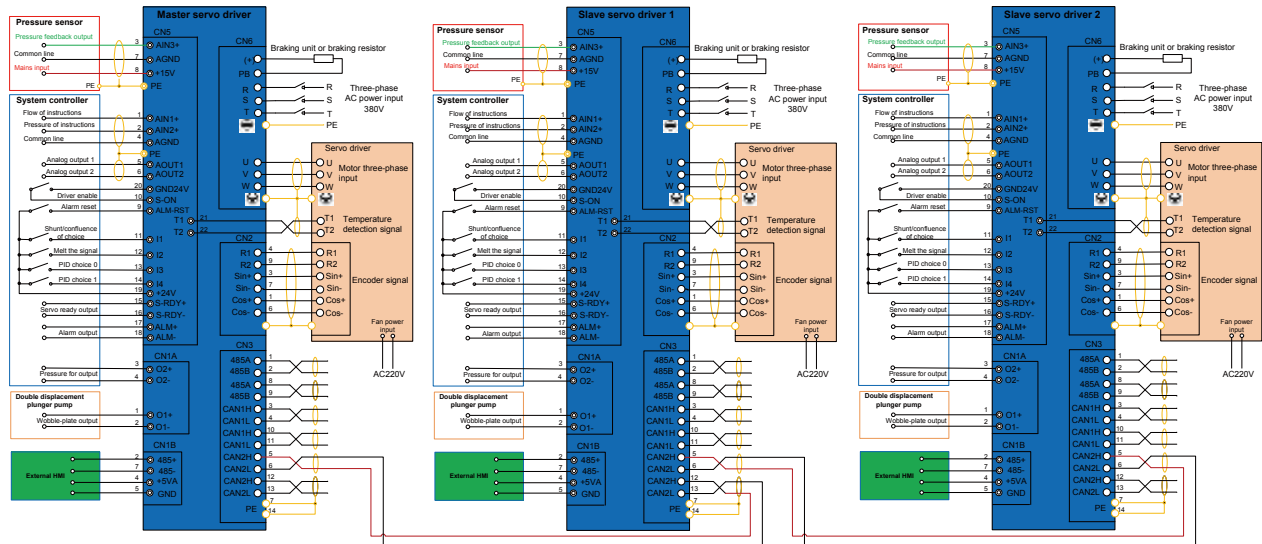

### Composite pattern control system diagram

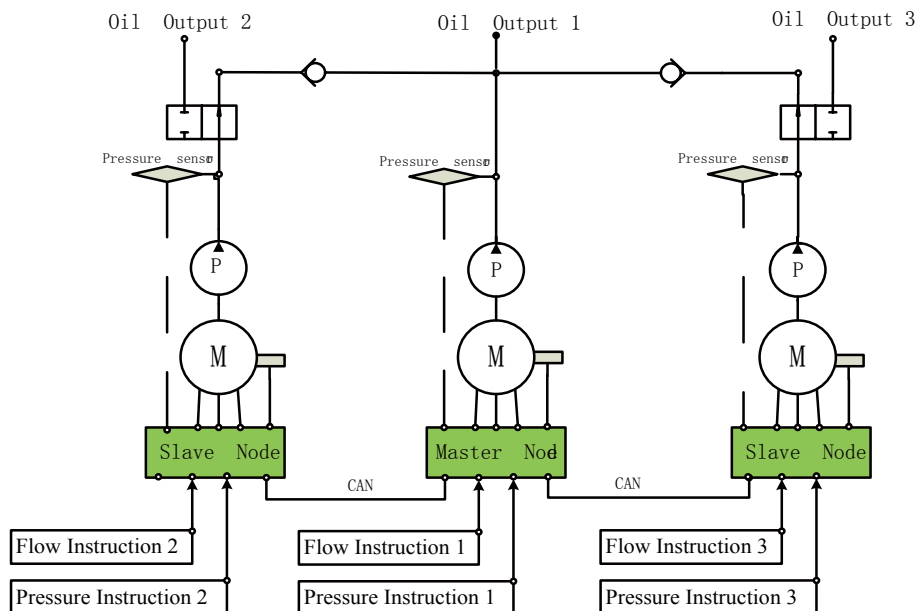

Multi-mode control system diagram

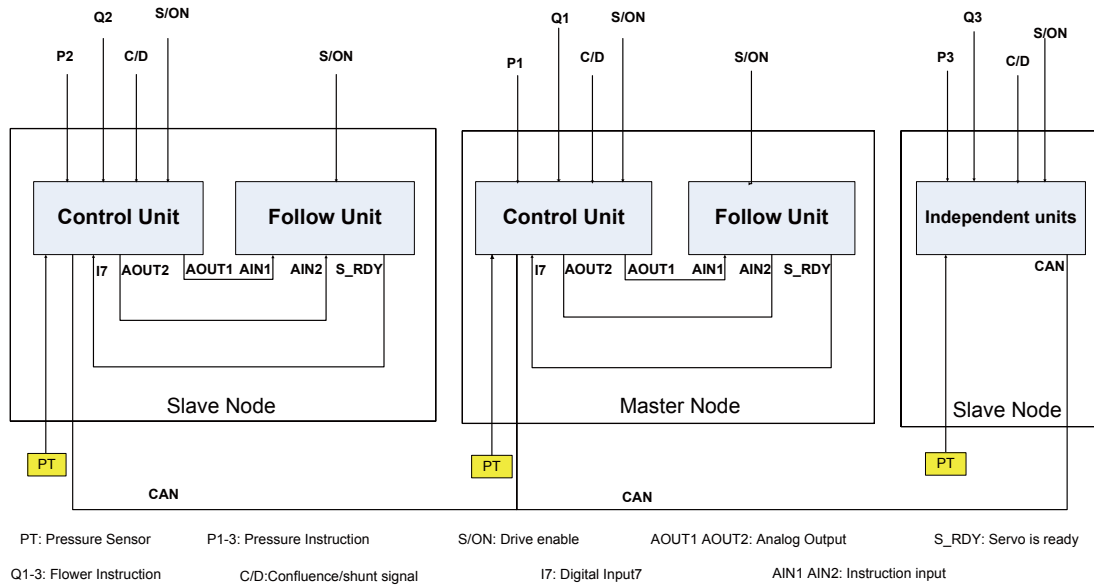

Multi-mode control system diagram

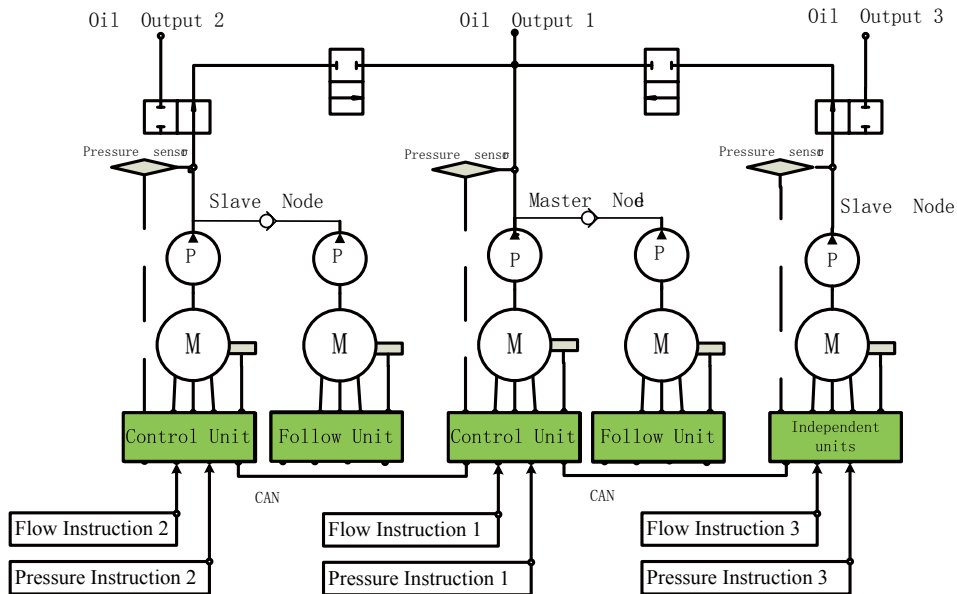



# Hydraulic servo configuration tables

## The naming rules of hydraulic configuration

**KT-110-18-HG-1**

①      ②      ③      ④      ⑤

① KINWAY		
② System flow(L/min)		
③ System pressure(MPa)		
④ Pump series:	HG	Sunny pump
	QT	Sumitomo pump
⑤ Oil pump type:	1	Single pump
	2	Double pump

## Hydraulic servo standard configuration table

MH800 HYDRAULIC SERVO SYSTEM					
Injection molding machine			Servo Retrofit configuration set		
System type	System flow(L/min)	System pressure (bar)	Pump model	Servo motor model	Servo driver model
KT-017-25-HG-1	17	250bar	HG0-08	MM18-2R7B-4-7A0	MH800-4R4-33
KT-022-25-HG-1	22	250bar	HG0-10	MM18-3R0B-4-7A0	MH800-4R4-33
KT-028-25-HG-1	28	250bar	HG0-13	MM18-4R4B-4-7A0	MH800-5R5-33
KT-035-18-HG-1	35	175bar	HG0-16	MM18-4R4B-4-7A0	MH800-4R4-33
KT-035-25-HG-1	35	250bar	HG0-16	MM18-5R5B-4-7A0	MH800-5R5-33
KT-044-18-HG-1	44	175bar	HG0-20	MM18-5R5B-4-7A0	MH800-5R5-33
KT-044-25-HG-1	44	250bar	HG0-20	MM18-7R5B-4-7A0	MH800-7R5-33
KT-055-18-HG-1	55	175bar	HG1-25	K036F20C18P	MH800-7R5-33
KT-055-25-HG-1	55	250bar	HG1-25	K060F18C18P	MH800-011-33
KT-070-18-HG-1	70	175bar	HG1-32-01	K060F18C18P	MH800-011-33
KT-088-18-HG-1	88	175bar	HG1-40-01	K072F18C18P	MH800-015-33
KT-110-18-HG-1	110	175bar	HG1-50-01	K078F20C18P	MH800-018-33
KT-132-16-HG-1	132	160bar	HG1-63-01	K105F20C18P	MH800-018-33
KT-132-18-HG-1	132	175bar	HG1-63-01	K132F18C18P	MH800-018-33
KT-160-16-HG-1	160	160bar	HG2-80-01	K132F18C18P	MH800-025-33
KT-160-18-HG-1	160	175bar	HG2-80-01	K132F18C18P	MH800-030-33
KT-200-14-HG-1	200	140bar	HG2-100-01	K208F15C25P	MH800-030-33
KT-200-16-HG-1	200	160bar	HG2-100-01	K187F18C25P	MH800-037-33
KT-200-18-HG-1	200	175bar	HG2-100-01	K235F20C25P	MH800-037-33
KT-250-14-HG-1	250	140bar	HG2-125-01	K235F20C25P	MH800-037-33
KT-250-18-HG-1	250	175bar	HG2-125-01	K235F20C25P	MH800-045-33
KT-300-14-HG-1	300	140bar	HG2-160-01	K235F20C25P	MH800-045-33
KT-300-16-HG-1	300	160bar	HG2-160-01	K290F18C25P	MH800-055-33
KT-300-18-HG-1	300	175bar	HG2-160-01	K341F18C25P	MH800-055-33

# / System Selection

## Pump selection

$$\text{capacity (mL/rev)} = \frac{\text{flow (L/min)} \times 1000}{\text{speed (rev/min)}}$$

Speed : the smaller value of maximum speeds of motor and pump  
Known : maximum pressure and flow in hydraulic system



## Motor selection

$$\text{torque (N}\cdot\text{M)} = \frac{\text{pressure (MPa)} \times \text{flow (mL/rev)} \times 9.55}{\text{efficiency of mechanical} \times 60}$$

Select a motor has the rated torque equals to half as maximum torque  
Known : maximum pressure and flow in hydraulic system



## Drives selection

$$\text{Peak current (A)} = \frac{\text{rated current (A)} \times \text{Max pressure (MPa)}}{\text{consistant working pressure (MPa)}}$$

Known : maximum pressure and flow in hydraulic system



Please consult with INVT engineers to get optimized system configuration.

# Hydraulic servo configuration tables

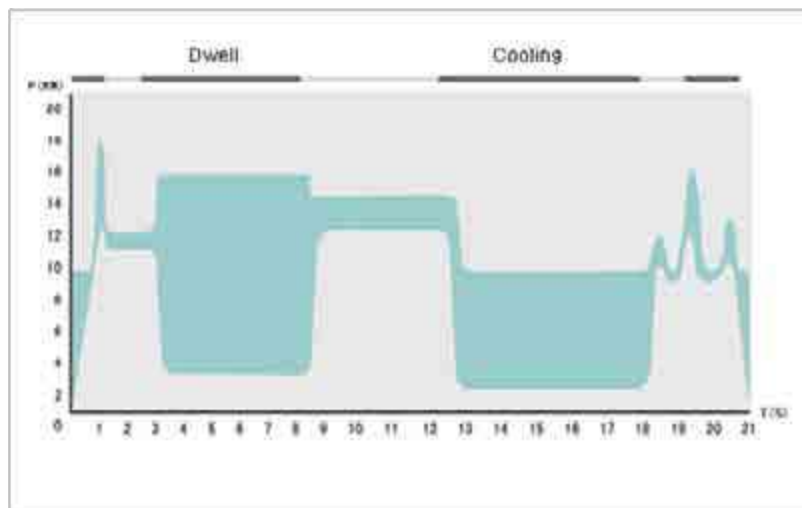
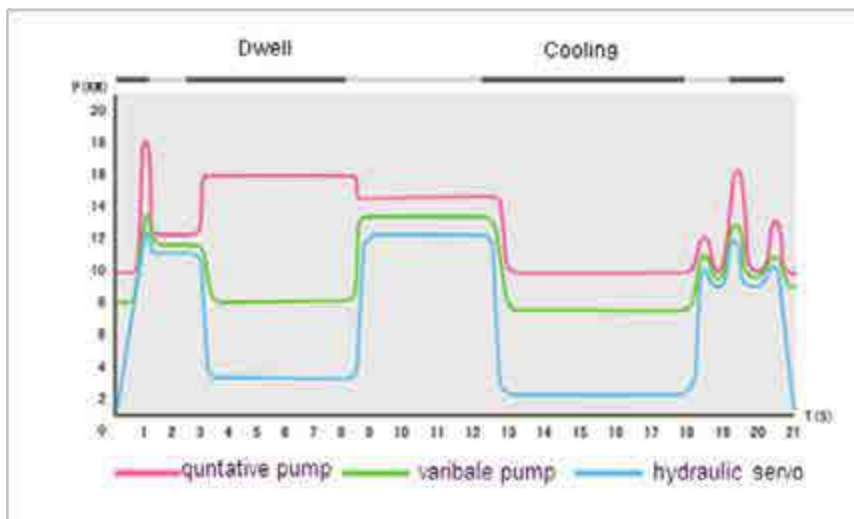
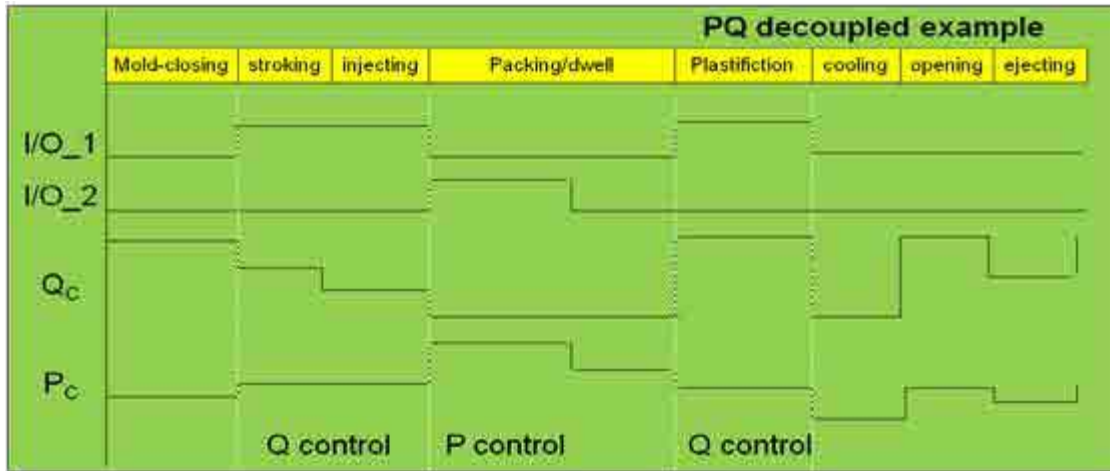

Servo Hydraulic system energy-saving rate is determined by Dwell & Cooling time in the molding cycle. Normally the power consumption rate is between 20%~80%.

# / Product application

---



Injection molding machine



Die casting machine



Shoes machine



Bottle blowing machine



Hydraulic press



Silicone rubber machine

# Sales Network



- INVT Sales & Service in 9 countries: Russia, India, Thailand, UAE, Italy, UK, Germany, Australia
- Sales and Service Partners in 57 countries

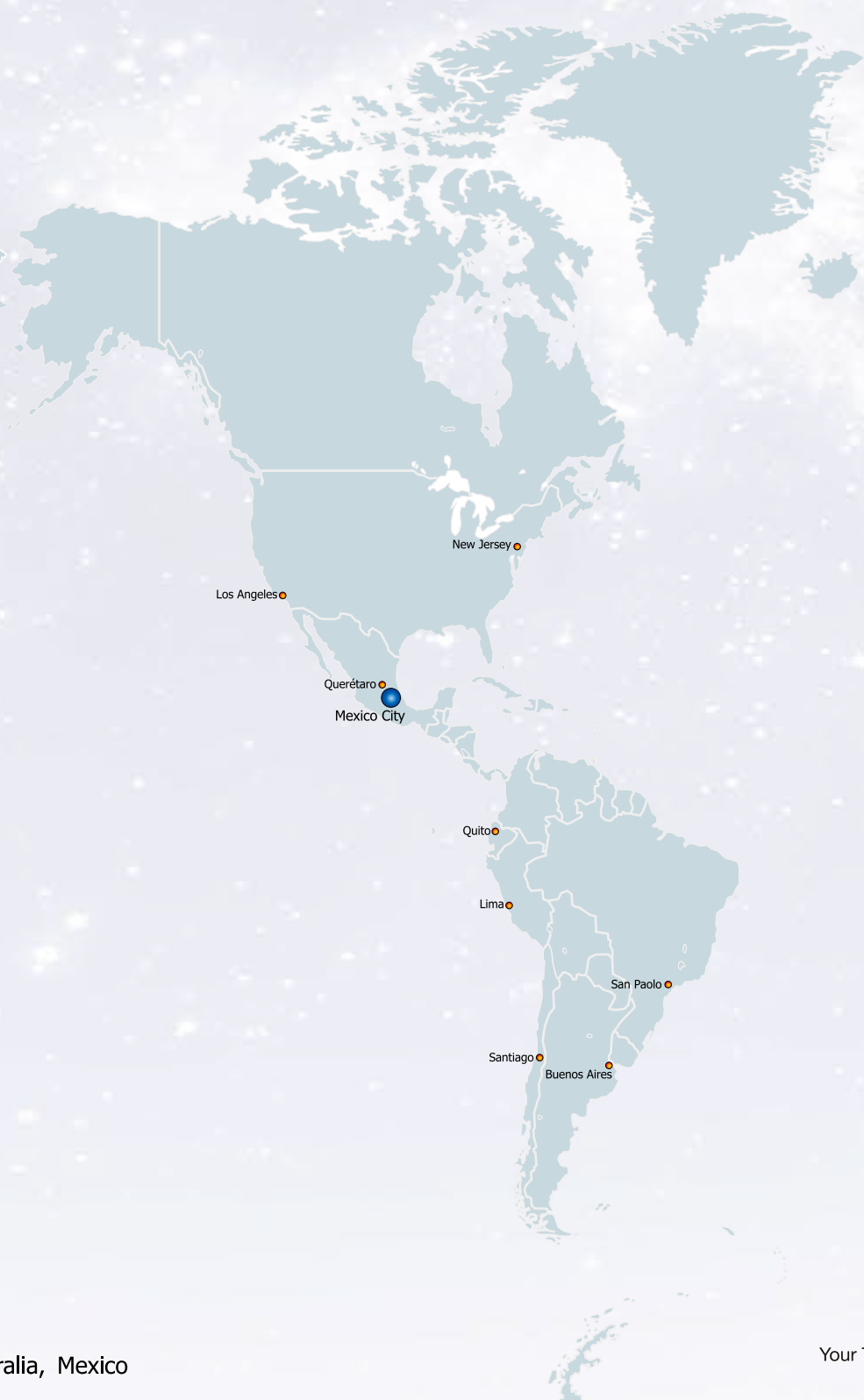

...alia, Mexico

**inv**t  
Your Trusted Industry Automation Solution Provider



# BETTER SERVO | BETTER SOLUTION

*Perfect combination of servo and solution*



Scan, landing INVT mobile website



Service line: 400-700-9997 ; +86-21-34637660 <http://www.invt-tech.com>

INVT INDUSTRIAL TECHNOLOGY (SHANGHAI) CO.,LTD.

No. 1 Building, No. 188 New Junhuan Road, Pujiang High Tech Park, Minhang District, Shanghai

**Industrial Automation:** ■ Frequency Inverter ■ Servo & Motion Control ■ Motor & Electric Spindle ■ PLC

■ HMI ■ Intelligent Elevator Control System ■ Traction Drive

**Electric Power** ■ SVG ■ Solar Inverter ■ UPS ■ Online Energy Management System

INVT Copyright.  
Information may be subject to change without notice during product improving.