

Control Circuit Wiring Diagram

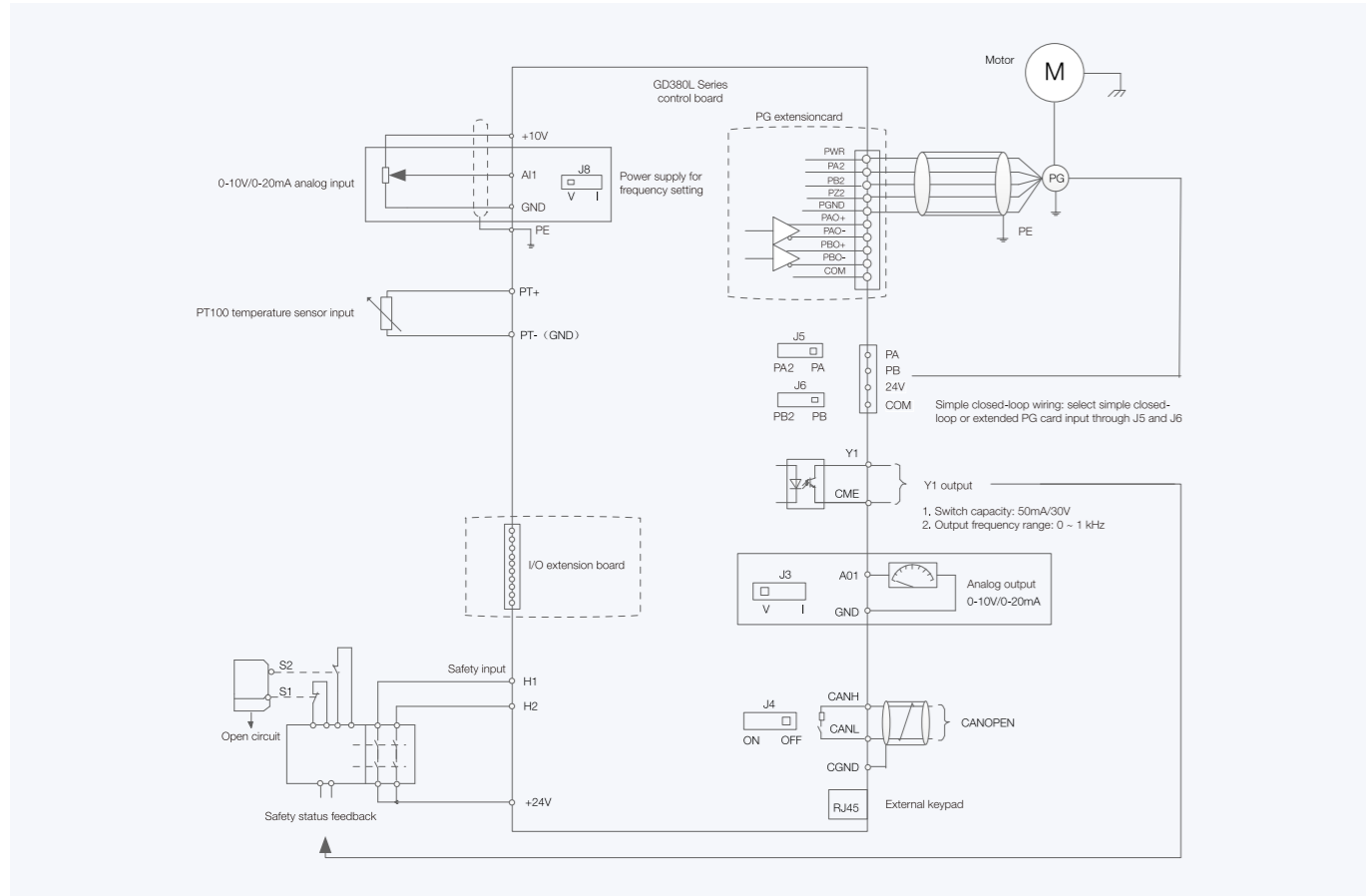

Goodrive380L Series Elevator AC Drive

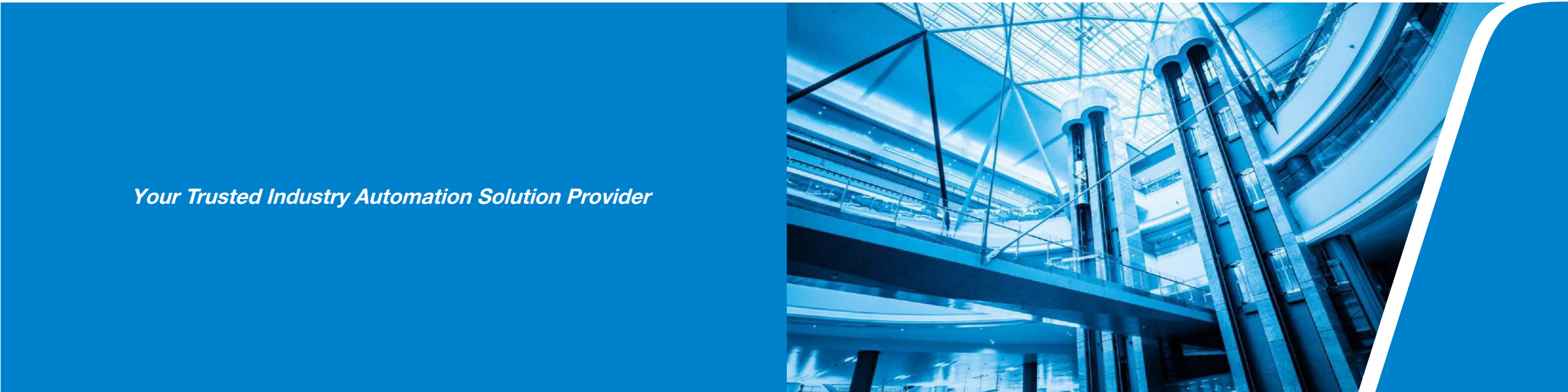

Your Trusted Industry Automation Solution Provider

I/O Expansion Board Wiring Diagram

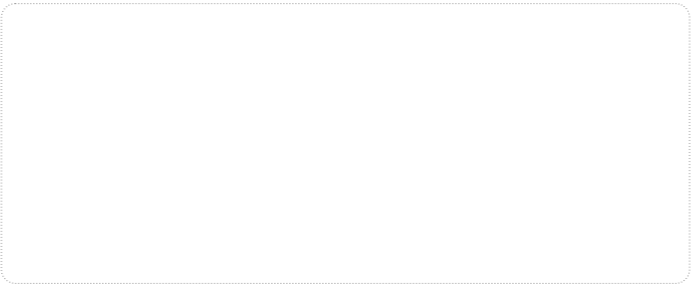
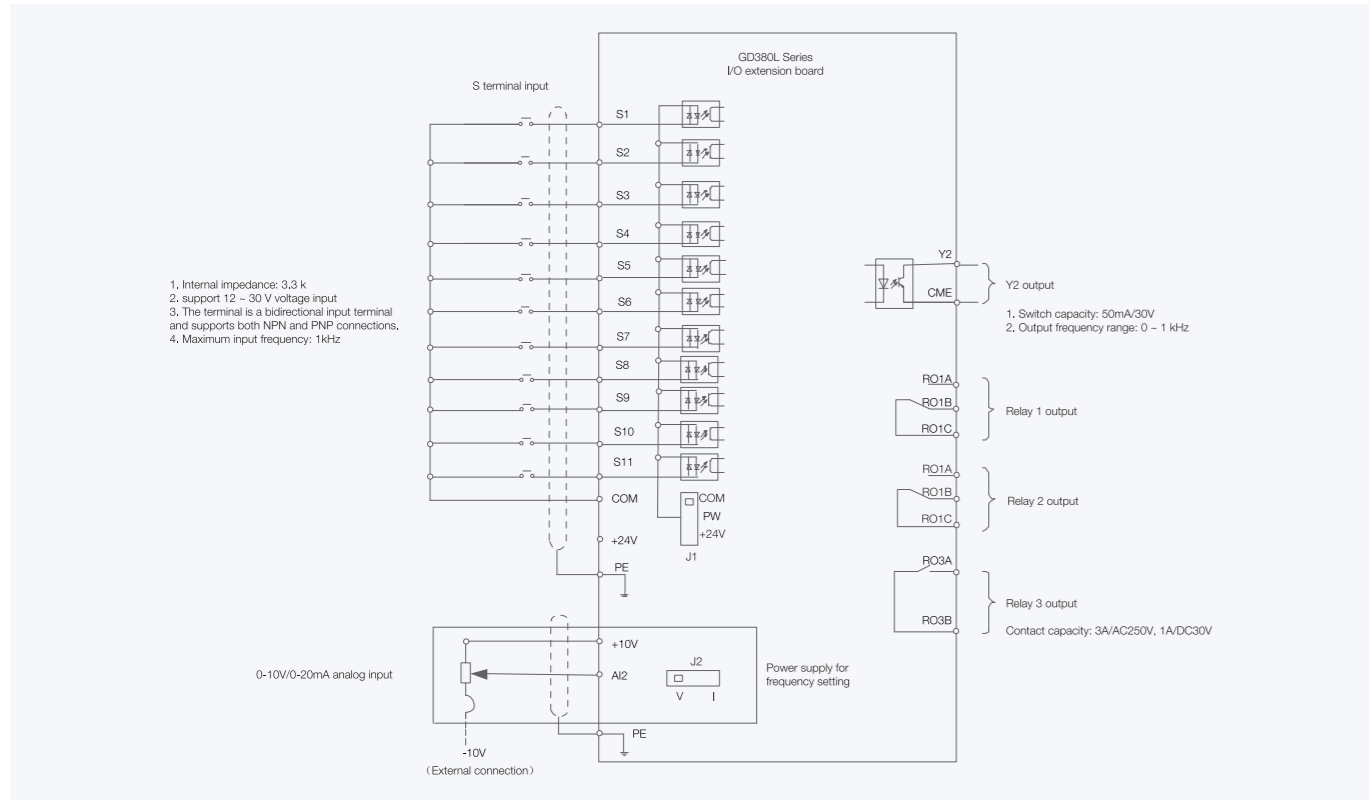

invt Service line: 86-755-23535967 E-mail: overseas@inv

SHENZHEN INVT ELECTRIC CO.,LTD. INVT Guangming Technology Building, Songbai Road, Matian, Guangming District, Shenzhen, China

- Industrial Automation:**
 - HMI
 - PLC
 - VFD
 - Servo System
 - Elevator Intelligent Control System
 - Rail Transit Traction System
- Electric Power:**
 - UPS
 - DCIM
 - Solar Inverter
 - New Energy Vehicle Powertrain System
 - New Energy Vehicle Charging System
 - New Energy Vehicle Motor



Introduction

Goodrive380L series elevator dedicated VFD is developed by using the new INVT control platform.

Goodrive380L adopts advanced frequency conversion vector control technology, and has made modular and customizable innovations on the basis of traditional frequency converters to meet complex individual needs. INVT integrates many years of industry experience and equips it with various motors and encoders, so that it can be widely used in freight elevators, passenger elevators and other fields. Powerful configuration and performance enable it to meet more precise usage requirements and provide more competitive solutions.

Features

- Standard built-in LCD interface
- Built in CANopen
- Built in incremental PG card
- Removable terminal board
- Ultra thin flat design(easy for MRL or integrated control panel)
- Flat or vertical book type installation
- Built in STO (SIL3)
- Optional built in C2 filter
- Energy Efficiency Certification (IEC/EN 61800-9-2)



Picture of compact type of GD380L

Model Designation Rules

GD380L - 7R5G - 4 - C - C2

① ② ③ ④ ⑤

Key	Sign	Description	Remark
Abbreviation	①	Product series abbreviation	GD380L is short for Goodrive380-LIFT
Rated power	②	Power range + Load type	7R5—7.5kW G-Constant torque load
Voltage degree	③	Voltage degree	S2: 1PH 220Vac(-15%)~240Vac(+10%) 2: 3PH 220Vac(-15%)~240Vac(+10%) 4: 3PH 380Vac(-15%)~440Vac(+10%)
Version	④	Product version abbreviation	Blank: Book type version C: Compact type version
Configuration information	⑤	Filter configuration	Default: Empty C2: With built-in C2 filter

Model Selection

Model	Power supply voltage	Rated power (kW)	Rated power (Hp)	Input current (A)	Output current (A)	Net weight (kg)
GD380L-2R2G-S2-C	1-phase 220Vac	2.2	3	24	10	4.1
GD380L-2R2G-2-C	3-phase 220Vac	2.2	3	11	10	3.9
GD380L-004G-2-C		4	5.5	17	16	4
GD380L-004G-4-C		4	5.5	13.5	9.5	4.05
GD380L-5R5G-4-C	3-phase 380Vac	5.5	7.5	19.5	14	4.2
GD380L-7R5G-4-C		7.5	10	25	18.5	4.3

Application Scenarios

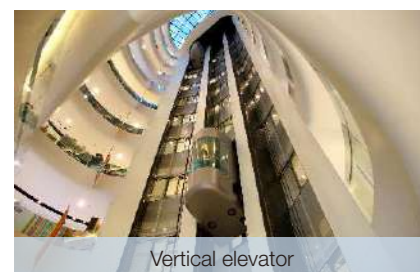

Vertical elevator

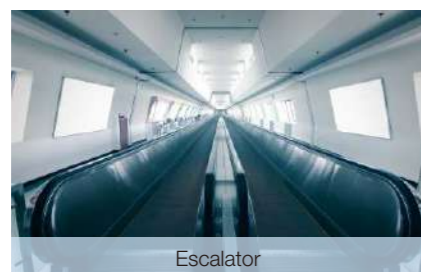

Escalator



Stereo garage

Product Specification

Function	Specifications	
Power input	Rated input voltage(V) Allowed input working voltage range: AC 1PH 220V(-15%)~240V(+10%) AC 3PH 380V(-15%)~440V(+10%)	
	Rated input current(A) See "Model Selection"	
	Rated input frequency(Hz) 50Hz or 60Hz Allowed range: 47~63Hz	
Power output	Rated output voltage(V) Rated output current(A) Rated output power(kW)	
	Rated output frequency(Hz) Equal to the input voltage, the error is less than 5% See "Model Selection"	
Running control	Control mode Maximum output frequency Adjustable-speed ratio Speed control accuracy Speed fluctuation Torque response Torque control accuracy Overload capability Starting torque	
	Sensorless vector control, closed-loop vector control 400Hz For open-loop vector control: 1:200 For closed-loop vector control: 1:1500 ± 0.5% (open-loop vector) ± 0.05% (closed-loop vector) ± 0.3% (sensorless vector control) < 20ms (sensorless vector control) 10% (sensorless vector control) Constant torque load: 150% of rated current: 1 minute 180% of rated current: 10 seconds 200% of rated current: 1 second For asynchronous motor sensorless vector control: 0.5Hz/150% For sensor-included vector control: 0Hz/200%	
	Used to provide more than 30 fault protection functions against faults such as overcurrent, overvoltage, undervoltage, overheating, phase loss and overload	
	Wall mounting temperature -10~50°C. The VFD must be derated if temperature is above 40°C	
	100,000 hours Meet CE Forced air cooling	
	Built-in for whole series	
	Standard configuration for VFD models ≥18.5kW. Optional built-in C2 filter can be configured, meeting IEC 61800-3 C2 requirements.	
	Others	MTBF Safety Cooling method Braking unit DC reactor EMC filter
		100,000 hours Meet CE Forced air cooling
		Built-in for whole series
Standard configuration for VFD models ≥18.5kW. Optional built-in C2 filter can be configured, meeting IEC 61800-3 C2 requirements.		
Standard configuration for VFD models ≥18.5kW. Optional built-in C2 filter can be configured, meeting IEC 61800-3 C2 requirements.		

Options

Braking Resistor

Model	Braking unit	Min.braking resistance (Ω)	Recommended braking resistance (Ω)	Recommended resistor power (W)
GD380L-2R2G-S2-C	Embedded	22	66	600
GD380L-2R2G-2-C		22	66	600
GD380L-004G-2-C		24	34	1200
GD380L-004G-4-C		80	130	1200
GD380L-5R5G-4-C		60	65	1600
GD380L-7R5G-4-C		47	50	1600

Note:

- Select the resistor resistance and power of braking units based on the data provided by INVT.
- Braking resistors may increase the braking torque of the VFD. Select a braking system depending on the actual working condition.
- If you need to use external braking units, see the instructions on dynamic braking units to set the braking voltage classes of braking units. Incorrect voltage classes may affect the normal running of the VFD.

PG Cards

Model	Picture	Category	Description
EC-PG101-05 EC-PG101-12 EC-PG101-24		PG card for asynchronous motor	5V Incremental PG card 12-15V Incremental PG card 24V Incremental PG card
EC-PG102-05		PG card for synchronous motor	Sin/Cos PG card
EC-PG106-05-T		Absolute encoder PG card	Special for ENDAT/SSI encoder like ECN1313, power supply output 5V±5%, 300mA

Dimensions

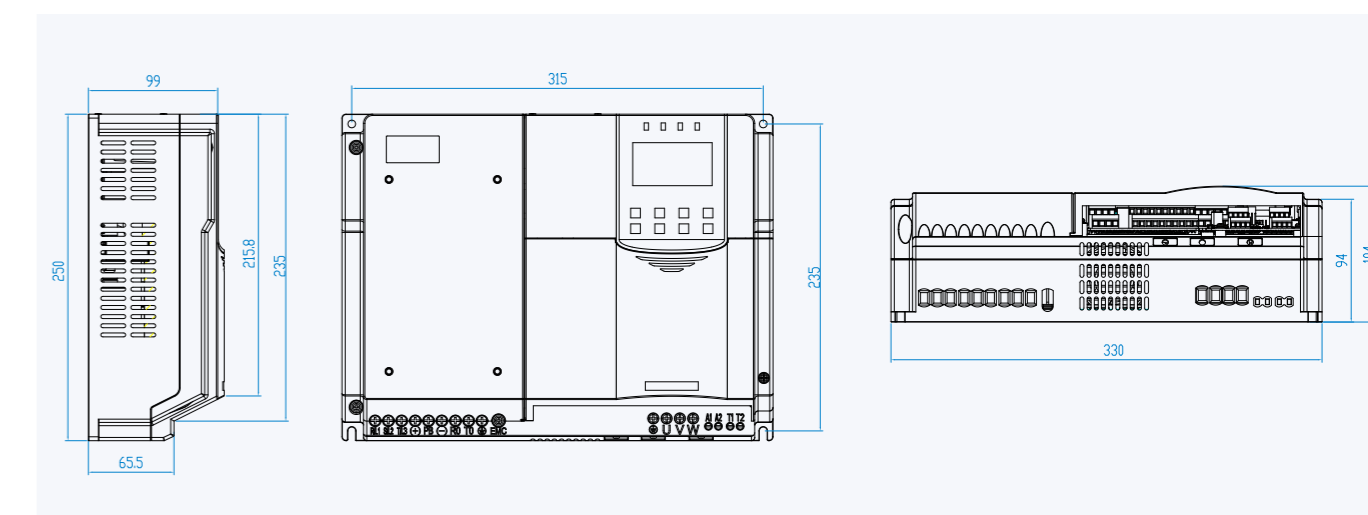

Standard Wiring Diagram

Main Circuit Wiring Diagram

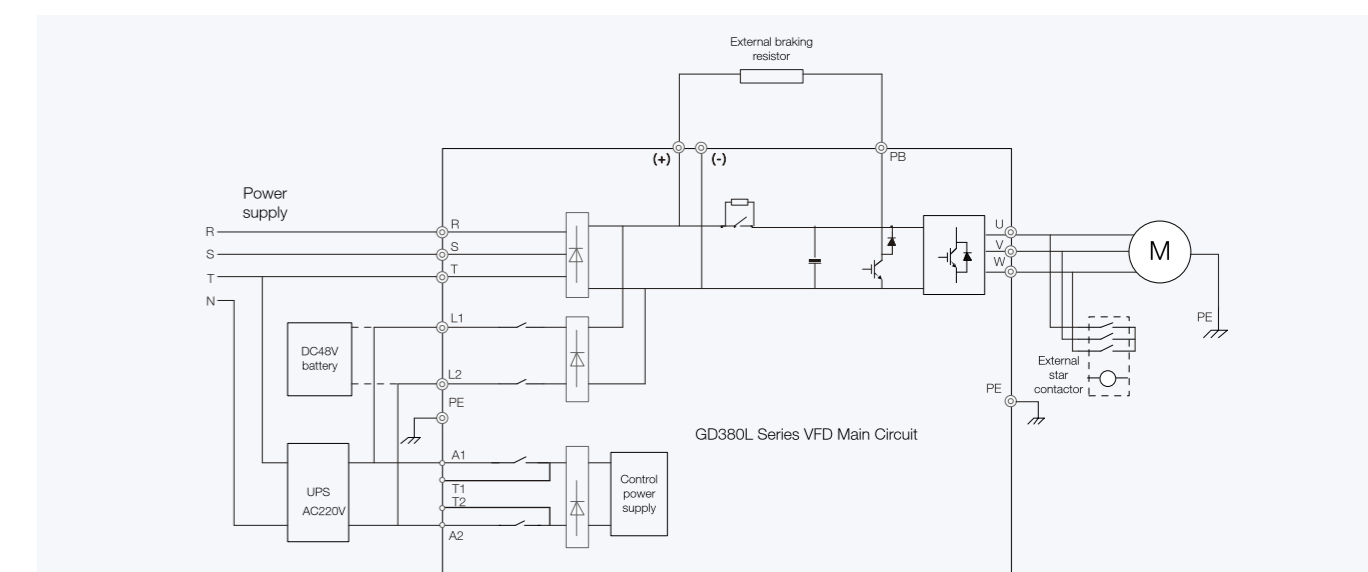

Note: T1 and T2 are used for maintenance and testing. A1 and A2 are prohibited from wiring when using T1 and T2.